

# Innovative Product Design Practice

Carl Liu Design Book 2

CARL LIU

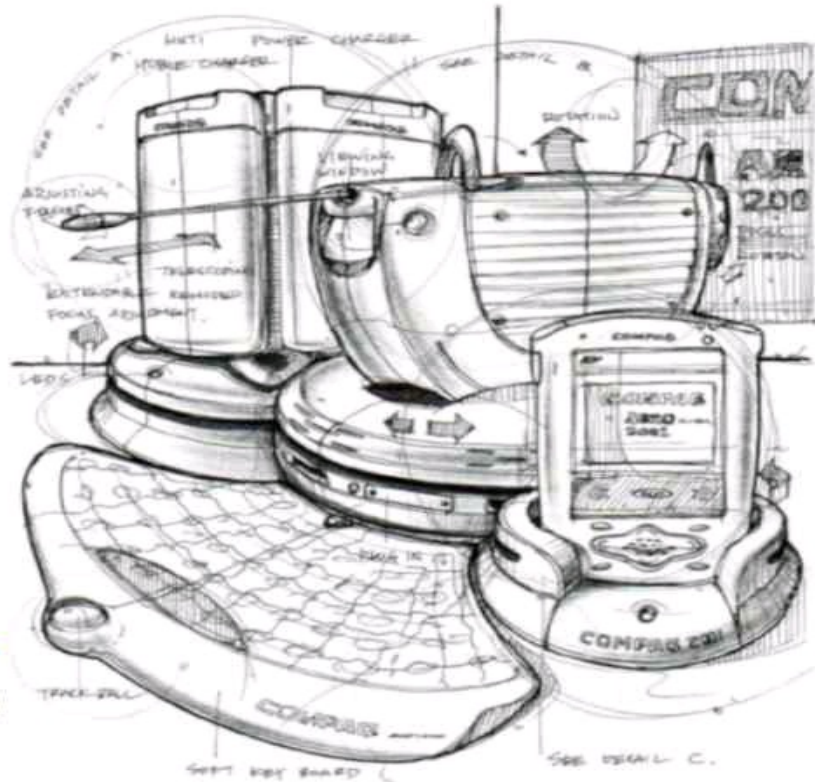

## Contents

AUDIENCE FOR THIS BOOK

CONTACT THE AUTHOR

ABOUT CARL LIU

PREFACE

Case study COMPAQ IPAQ

Case study Nike Running Watch Trix300

Case study VORTEX RING SHOOTER

Before Demo...What tools?

Why sketching?

MY MP3 PLAYER

SCOOTER

A LITTLE STORY ABOUT ME

ACKNOWLEDGEMENTS

## AUDIENCE FOR THIS BOOK

This book is for people who want to improve their Industrial Design skills and design knowledge. It will be very valuable and useful for:

- ID students who want to continue developing their sketching techniques,
- ID designers who want to learn adopting various design process form real design projects,
- Those who have interests in creative industries,
- Business decision makers who are hesitating to believe in power of design.

## CONTACT THE AUTHOR

Carl Liu

Email: [liu.carl@gmail.com](mailto:liu.carl@gmail.com)

Website: [www.carlliu.com](http://www.carlliu.com)

## ABOUT CARL LIU

Carl is the founder of brand Carl Liu. He is a well-known Chinese industrial designer and currently works as a partner/senior design director of Idea Dao Design Shanghai. He earned his design degree from the world-famous design school Art Center College of Design in US and Switzerland. Later he worked at the award-winning design studio Astro and Motorola advance concept design group total for almost seven years before he moved to China. He also tough a drawing class at CCA during his stay in the U.S. Carl's signature designs included Compaq iPaq PDA, Nike running watch Triax 300 and Triax 50. These products had been sold millions and won international awards like G-Mark, IDSA and I.D Magazine. His designs have demonstrated that good design matters to successful business.

Carl is enthusiastic about elevating the design level in Asia. He has published two design books Carl Liu Design Book and Innovative Product Design Practice since 2005. His books have influenced students and designers world wide. They has become textbooks for many design schools and universities. Due to the impact of his design philosophy and sketching technics, he gets invitation for workshop and talk all the time from different countries. He is also frequent invited as jury member of international design awards. The most recent one is iF concept award in Germany.

Carl loves to design. He establish his own design brand Carl Liu as a design platform for talent designers to join and share experience. His belief of Carl Liu is a brand of creative living and quality lifestyle. Green thinking is also one of the major criteria when Carl works on new creations. So far He has grain over eighty design patents.

## PREFACE

I have to admit that China designers have kept learning and growing in an unbelievable speed just like the new skyscrapers popping up in Shanghai and Beijing in recent years. Although the general environment of design business is still immature, the designers challenge themselves to follow the right design perspective then modify the western methodology into the unique eastern culture. Many design related international conferences, awards, exhibitions and tradeshow have held here in the mainland. Famous architects and well known designers from world- wide are invited by the China government to work on significant projects. They have brought in their expertise and become frequent visitors. Design related cooperation between local companies and international enterprises are aggressively and intensively bidding the projects for the coming 2008 Beijing Olympics and 2010 Shanghai World Expo.

Meanwhile, Hong Kong, Shenzhen and Shanghai are giving their best offers to win over both local and foreign design businesses in town to become the Asia design center. All these actions and evidences show that design will play a lot more important role than ever in China. Furthermore, I can almost predict the term of design will be soon recognized by the general public. Once the healthy eco system of design has well established to form a design food-chain, China design will be as good as other developed countries, even beyond.

This book is divided by two major parts. The first part presents real design cases along with insight stories while working on the projects. The ideations, sketches and layouts are arranged in chronography so the readers can easily understand the creation process. The second part shows the step by step sketch demos which are strongly requested by the students and designers. I have included the traditional hand sketches and computerized digital drawings on Wacom tablet. I also briefly explain the characteristic of different media for the readers' reference to choose the most comfortable media to use. Once again, despite my limited knowledge, I hope this book can assist you as a design tool.

When Compaq approached Astro Studios for the Ipaq PDA project, it started as a simple and almost a restyling task. Astro took this great opportunity to demonstrate that a great design and a think-out-of-box marketing strategy could turn a business around. I was very lucky to be one of the core team members to design the product from the concept stage to the production phase. Based on a reliable research report of mobile computing use case study done by a respectable research consultancy and Astro's own observation from daily PDA users, Rob Bruce and I finally came out the expansion jacket concept that allows the Ipaq PDA to be personally configured for the user's personal options. Rob was my design manager for this project. He was responsible for the design direction and the communication between Compaq and Astro. I was on the other hand more focus on the hand-on design and later on the communication with our OEM vender HTC for production details.

Ipaq had a code name "palm killer" in the beginning because Palm Five was quite a hot seller at that time. Palm Five was designed by IDEO; it was sleek, beautiful design, well made and the size was very compact. Palm products were very popular; it shared 70% of PDA market at that time. On the other hand, the Window based Pocket PC was just started and it did not receive good reviews from consumers. Astro realized it was a tremendous challenge not only for industrial design team but also a difficult and risky task for the engineering team and software team to pull it through.

Co-working with specialized marketing research experts, Astro analyzed the quantitative data aligning with designer's killer instinct then came out eight design directions according to different user groups. Scenarios, image boards and story boards were heavily used for analyzing the users' behavior on carrying portable devices. We wanted the design to be focused on people-centered because human factor and usability should not be after thoughts. We nailed down few keywords for the development themes such as personalized, expandable, and professional. Rob and I agreed that in order to overcome the palm products we had to emphasize on Pocket PC's multi-tasking and multi-capability as a powerful mobile Swiss knife than just an electronic organizer or an address book. The final design had to look small, elegant, intelligent and sophisticated. The final design had to operate intuitively. The final design had to work seamlessly between the hardware and the software.

The expandable jacket concept was designed to fit different users in different usages without burden too much technology into a small device. Six weeks after the first presentation, the Astro team went back to Houston and presented this brand new idea to their product team. The initial proposal was well received by the project management team in Compaq. To pursue the idea and to go down the road we were envisioning the product could become, we had to sell the idea to their higher-up business team because the end-product would take a lot more resource than the original project scope. Brett Lovelady, president of Astro studios, thought we had a great chance to start a new era for electronic hand held devices.

He decided to fully support me and Rob for shooting a short film to explain the use cases and to give the future design vision for promoting the unique concept. It was quite an exciting experience. The entire studio was so motivated and energized to put up the best show. Almost everyone participated in the acts. Stefano Moris did a phenomenal final editing and digital work to complete the clip. The final outcome was very satisfied and effective.

We didn't get to present the clip ourselves but instead sending it over by mail to their product team. The scenario clip and an appearance model finally reached to Michael Capellas, President and CEO of Compaq Computer Corporation at that time. We later heard Michael was very excited about this expandable jacket concept and the entire product line strategy. He gave his authority to reconfigure the resource plan to continue co-developing our "Palm Killer".

After the design direction was locked down, we soon hit the reality and had to work parallel with the engineering team in Taipei and Houston. One person I like to mention here who helped me and Rob so much during the mechanical engineering phase. Bruno Richard worked as a contract mechanical engineer. He used to work at Function Engineering which was a very well known engineering consultancy in Silicon Valley. He was one of a few creative engineers I knew. He liked challenges and was not afraid to think out of the box. Whatever any crazy idea the designers came out he never said no first but tried to find a possible engineering solution. I remembered there was a trip when Bruno, Rob and I worked at HTC Taipei. HTC was our manufacture partner who was responsible for the product tooling, massproduction and assembly. To keep the sleek design direction and the most

compact size, we were brainstorming for the most ideal component architecture. After many long-hour meetings with HTC engineers, we had settled for all the major components but the polyphony speaker. There just wasn't a proper spot to fit the speaker. Finally, I was sort of joking and suggested to place the 20mm speaker underneath the joystick due to the limitation of keeping the size pocketable, besides we didn't want the speaker on the back of the product to ruin a good audio quality. Form my experience, most engineers would probably freak out and yelled "no way". Especially we were under a lot of pressure of a very tight schedule. However, Bruno did not think the idea was totally unacceptable. Instead, we were brainstorming for the possibilities. He roughly drafted out few possible proposals the next day then we shared the proposals to the HTC engineers. The idea got turn down as I expected. Bruno did not give up and proposed few more feasible manufacturing solutions. Having the strong reasons to back up the ID design, Rob and I insisted to remain the final ID. HTC team finally agreed to give a try but along with a back-up plan. I believed a creative engineer could really help a designer to realize his or her innovation. Aside accurate marketing researches, advanced manufacturing capabilities and innovative designs, creative engineering would play a critical role to create wow factors for new products. Taking Sony as an example, it would not have so many amazing inventions and engineering breakthroughs if there were no strong supports by its creative engineers.



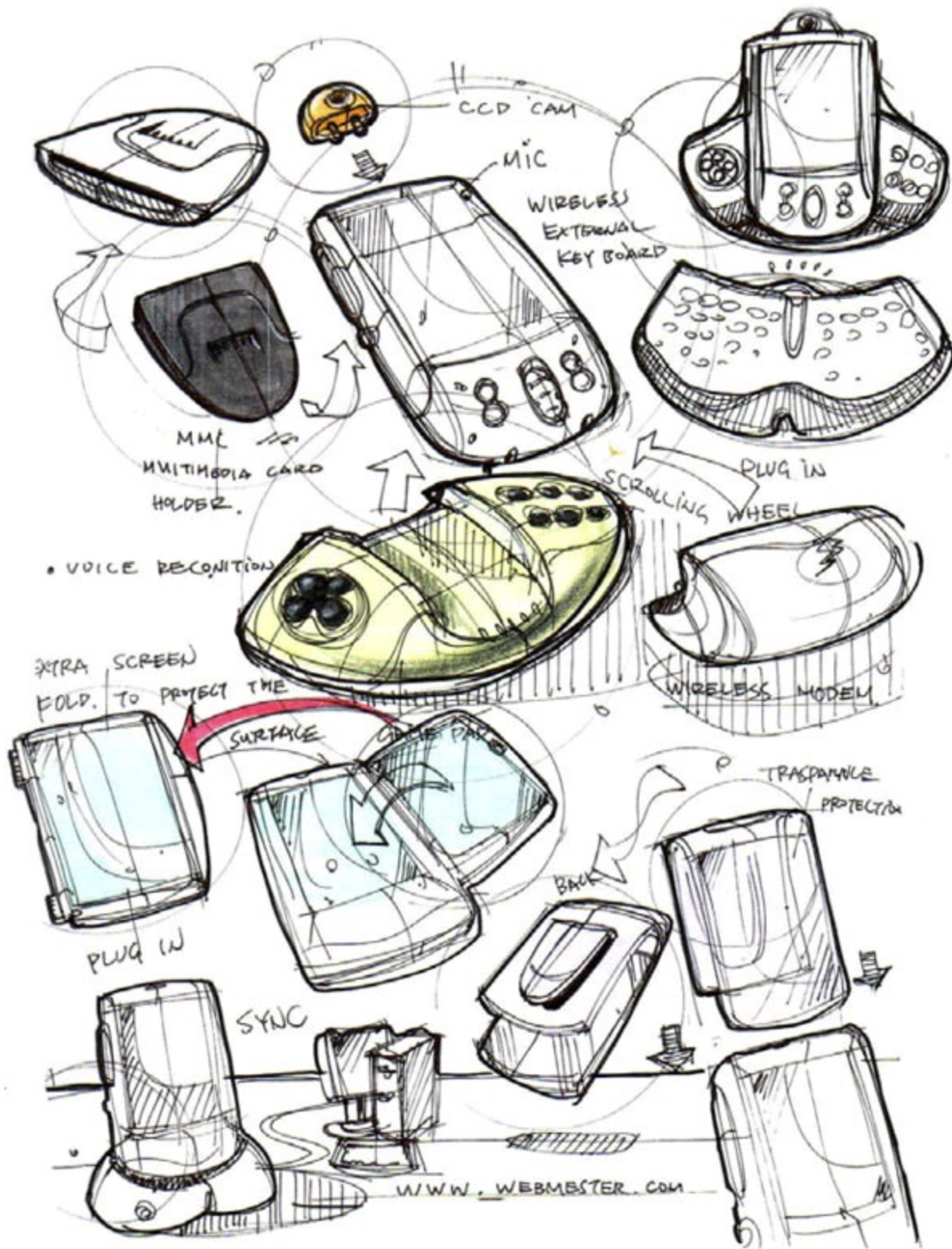

Slide-in optional game controller for better gaming experience. Screen protection cover opens from left or right of the PDA.

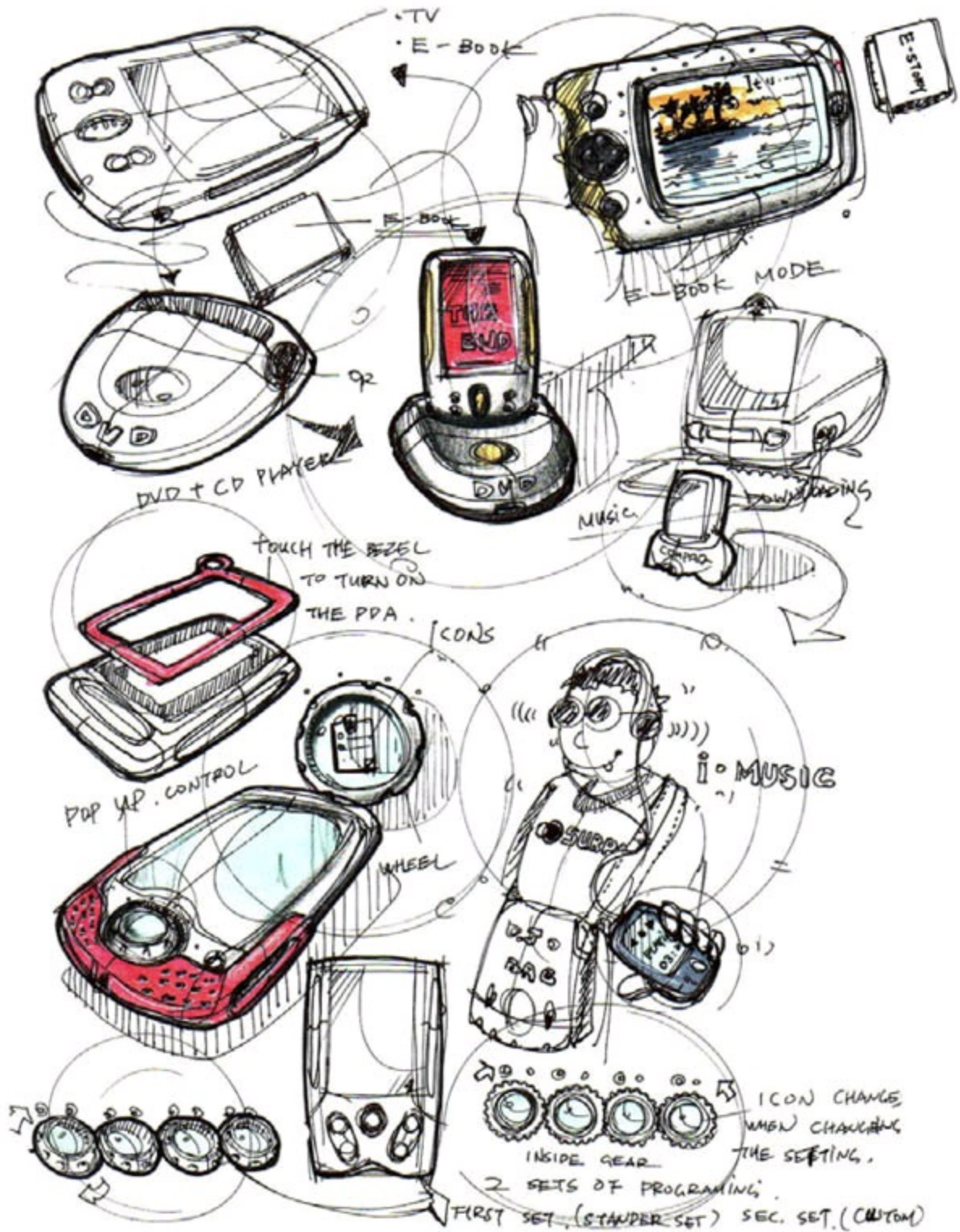

Gear-like mechanism for switching keys to different mode. I like this idea because it gives more key options to the user.

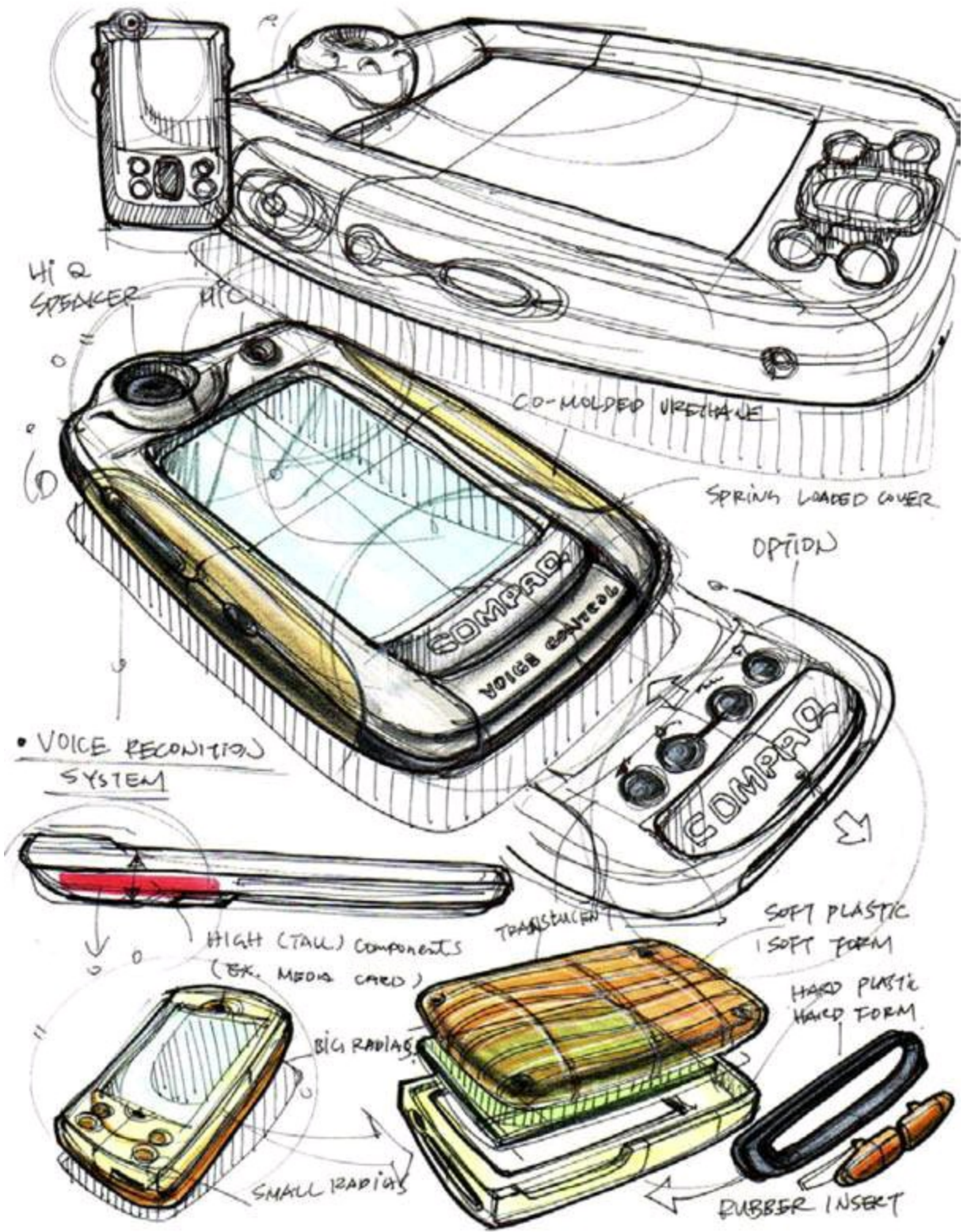

Wrapping with soft rubber for comfortable holding.

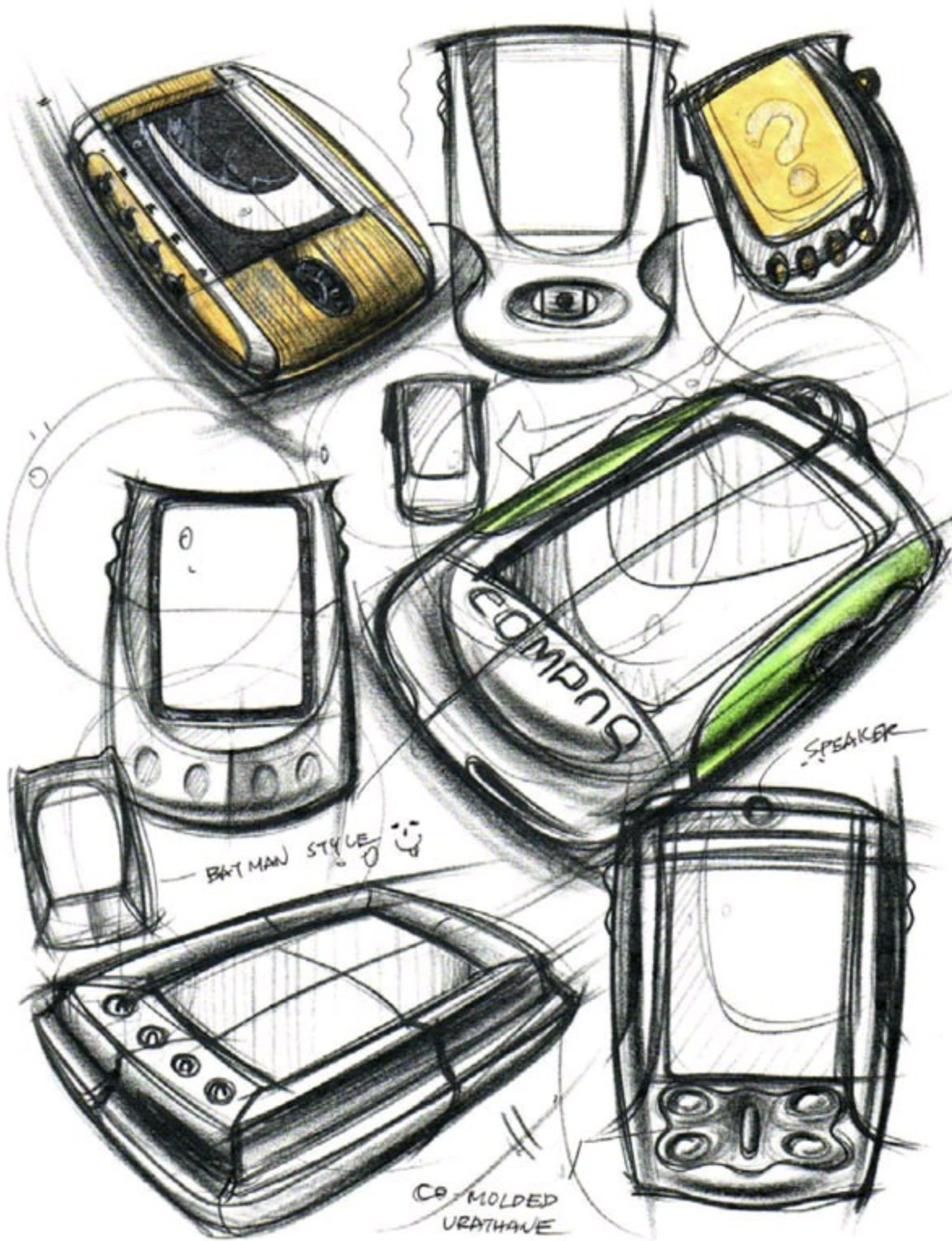

- DICTIONARY
  - CALCULATION
  - ORGANIZER
  - FINANCE
  - REFERENCE
  - GAMES
  - TIMES
  - SYSTEM
  - CALENDAR
  - CARD
  - HOT SYNC
  - TO DO LIST
  - NOTES
  - DOWNLOAD SOFTWARE
- SIMPLE CALCULATION  
METRIC CONVERSION  
MATHS FORMULA
- SCIENTIFIC CALCULATION  
UNIT CONVERSION  
CURRENCY CONVERSION
- FINANCIAL MANAGEMENT  
LOAN INTEREST  
FIXED DEPOSIT  
LOAN BIDDING
- TRAVEL GUIDE  
SIZE EQUIVALENT  
WORLD FESTIVAL  
PAST POEMS
- ANALECTS OF CELEBRITY  
HEALTH GUIDE  
ANALECTS OF FLOWERS  
GLOBE TELE INFORMATION
- INFORMED GAMING \*

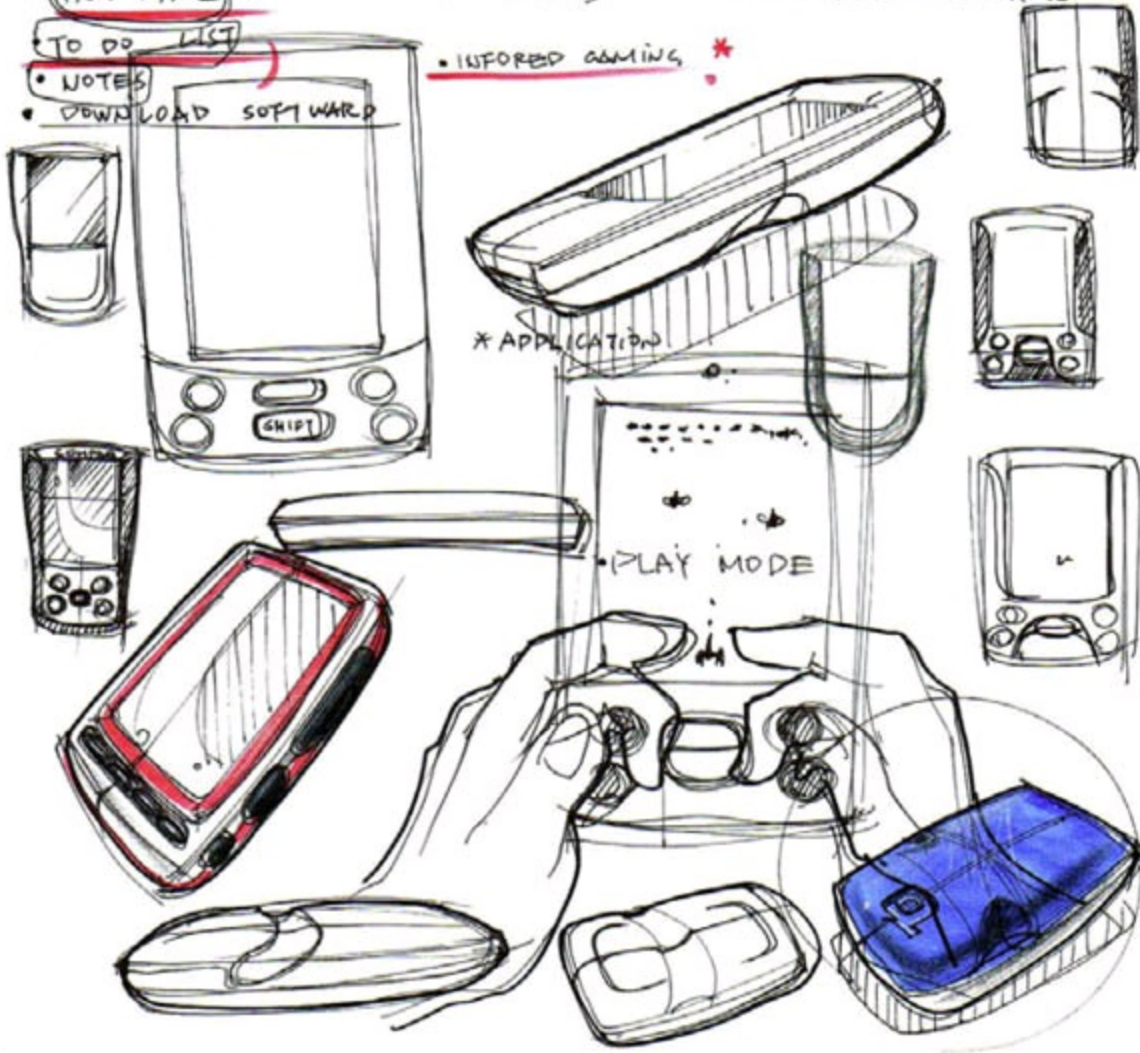

Write down descriptive and notes to exam critical facts.

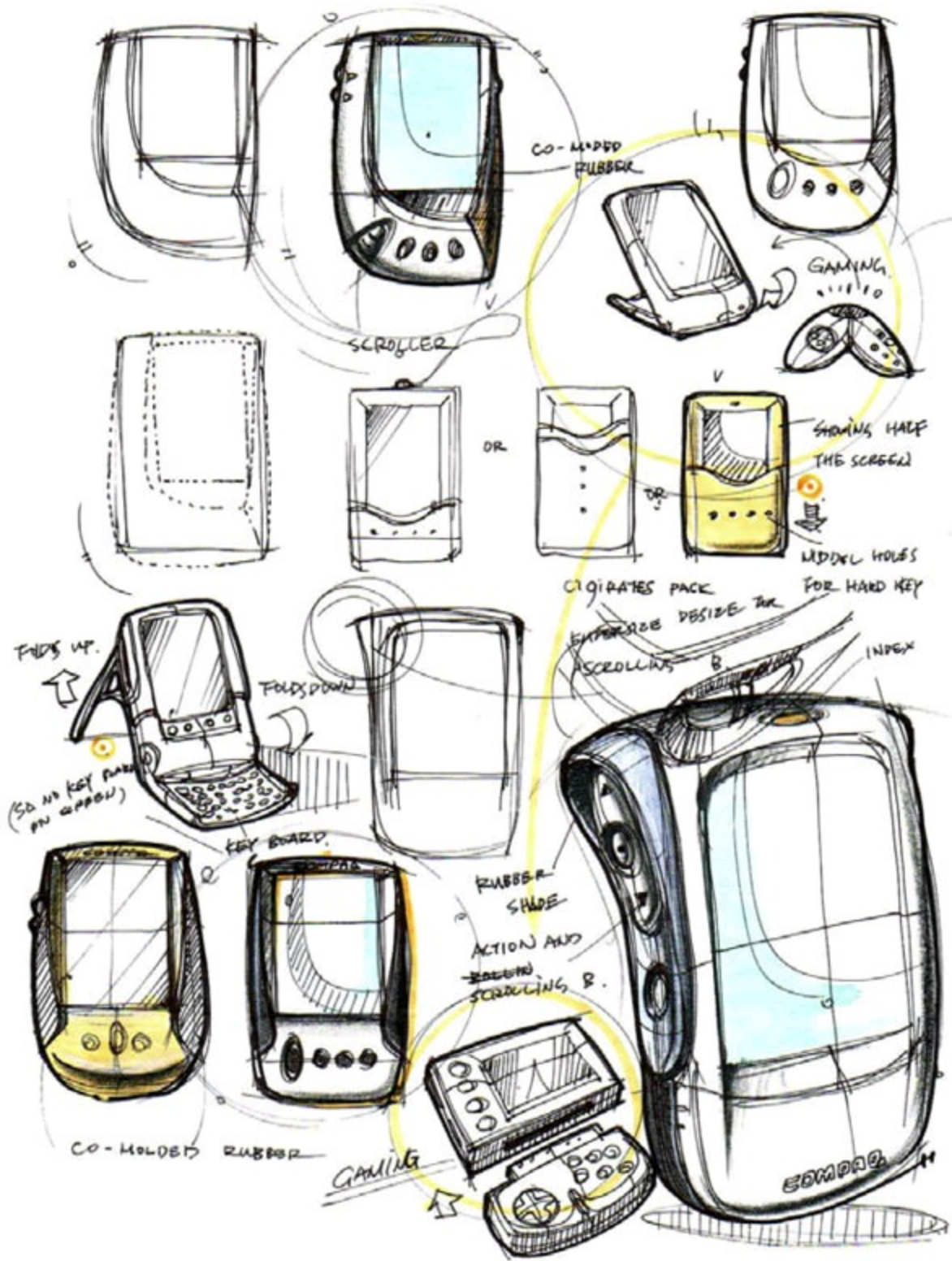

Play out control zone as a design character. Try asymmetrical design

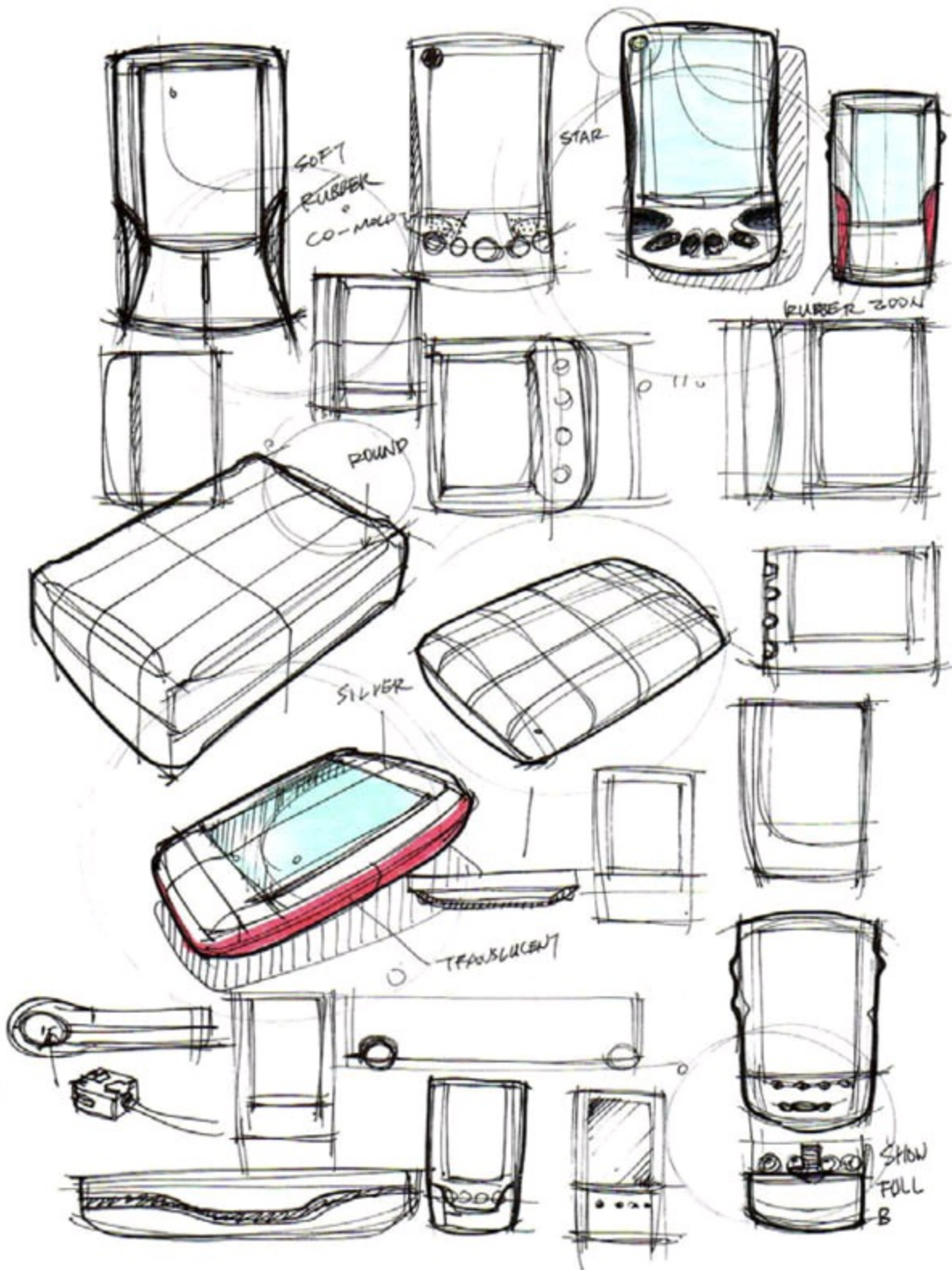

Try two-tone CMF (color, material, finish) to make the product look thin.



Aggressive S shape design to make the product stand out.



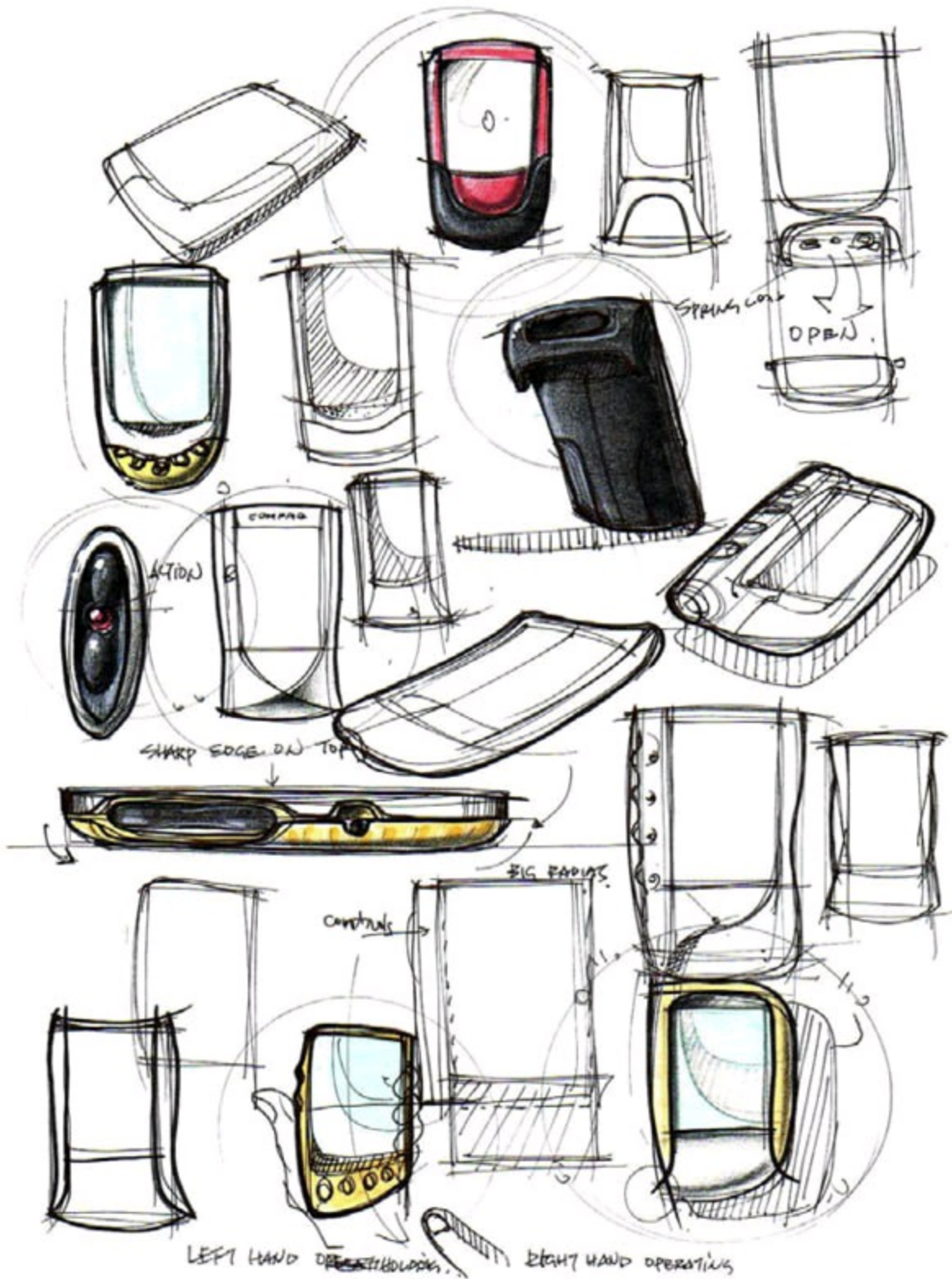

Very soft bottom makes the device not so serious.

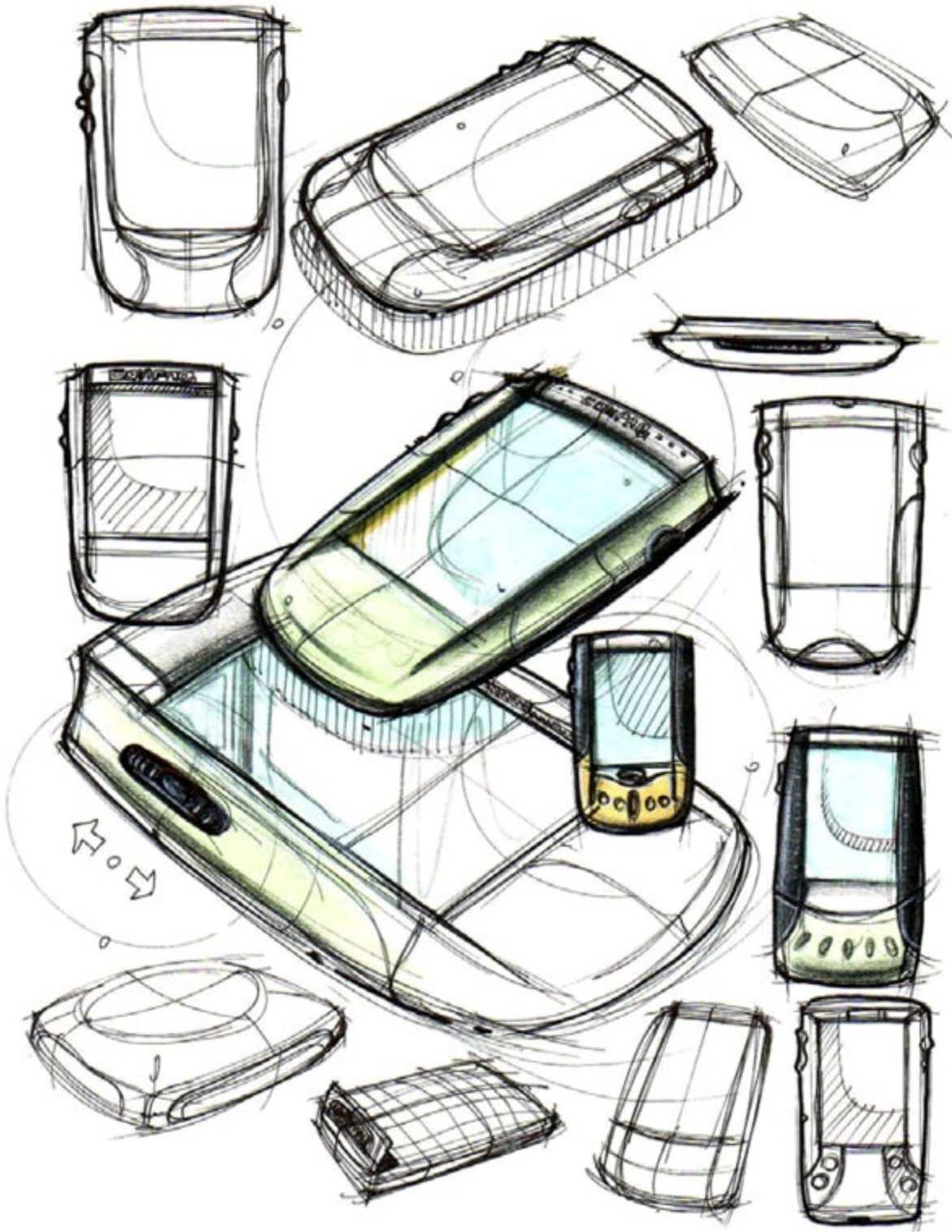

Cut out chamfer for scroller and side keys, easy operation?

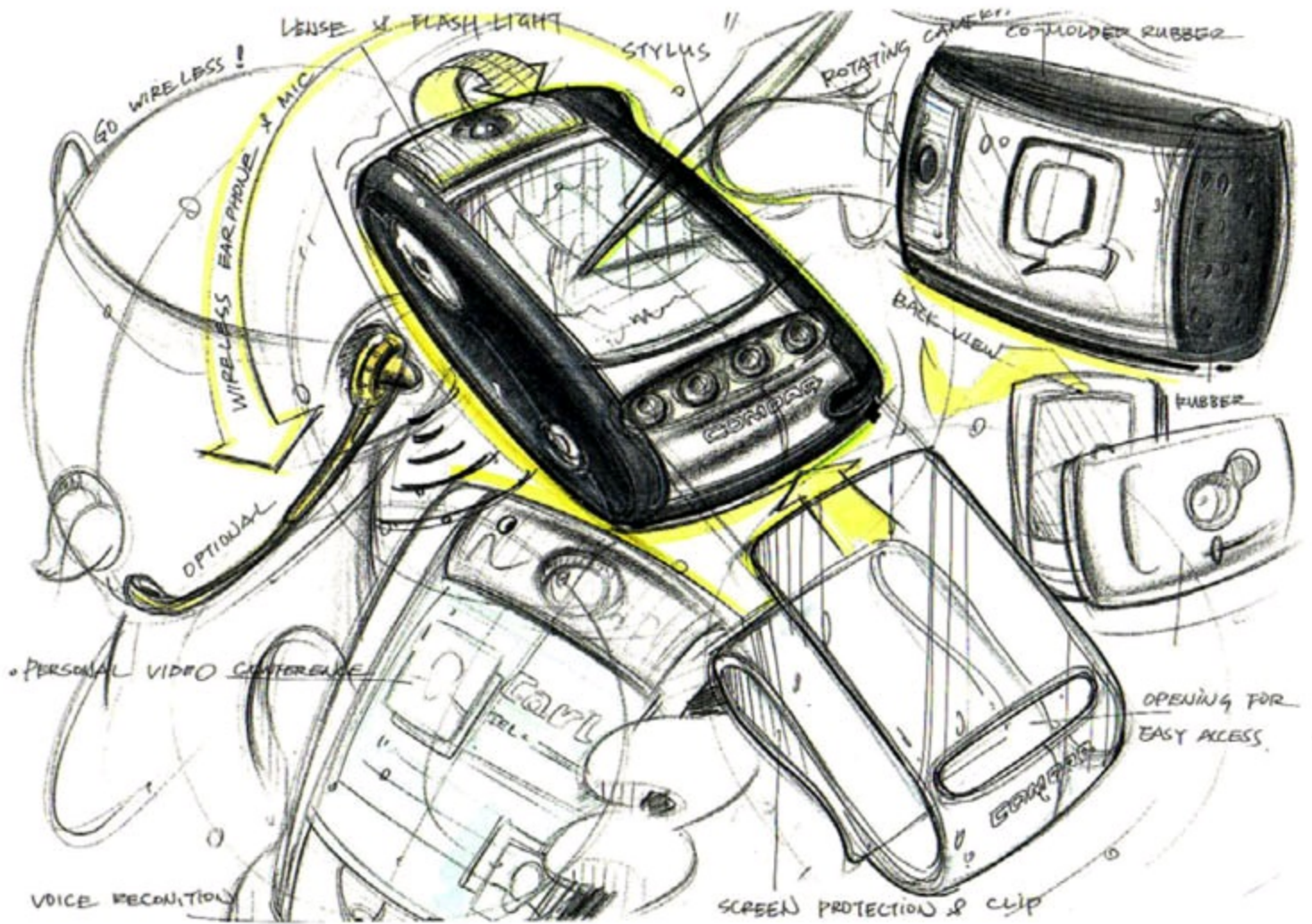

Belt clip and screen protection in one. Quick scenarios for PDA usage. Tried to get an overall feel of what a PDA can be

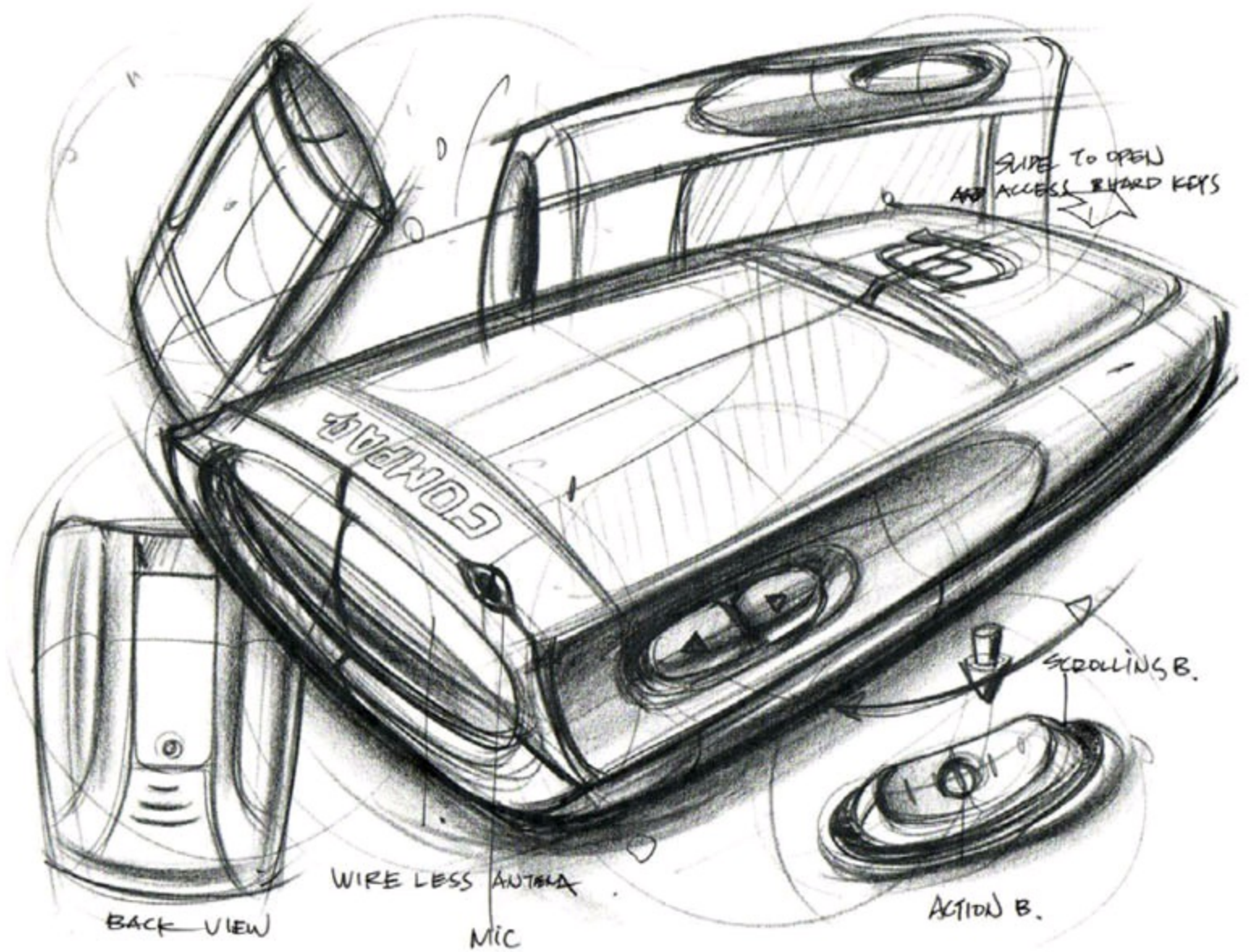

Ergonomic design for ease of use on side keys. I was thinking the gutter like surface could maybe help fingers to locate the keys.

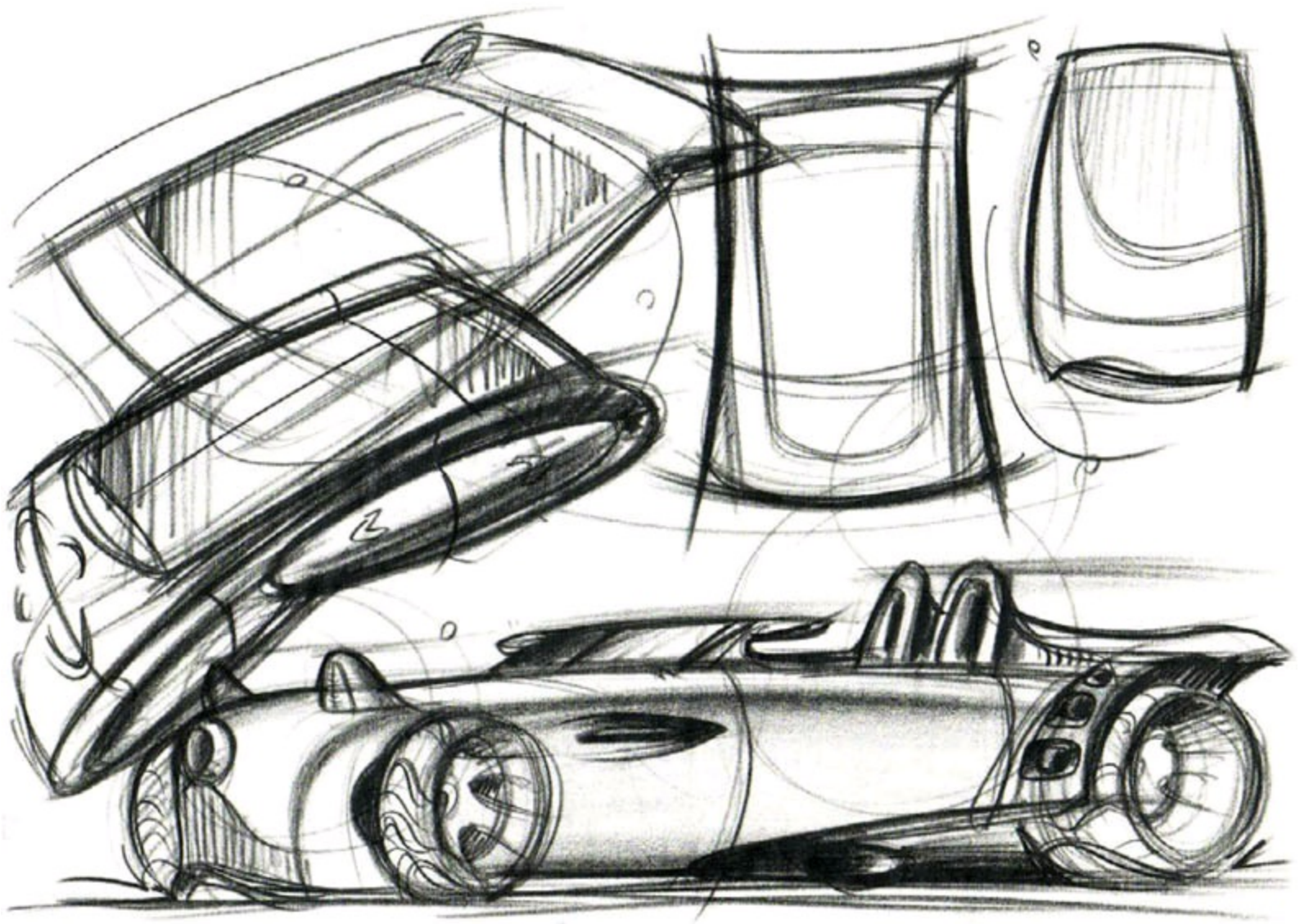

Oversize side keys protected by rubber bumper. I did a car sketch just for a break.

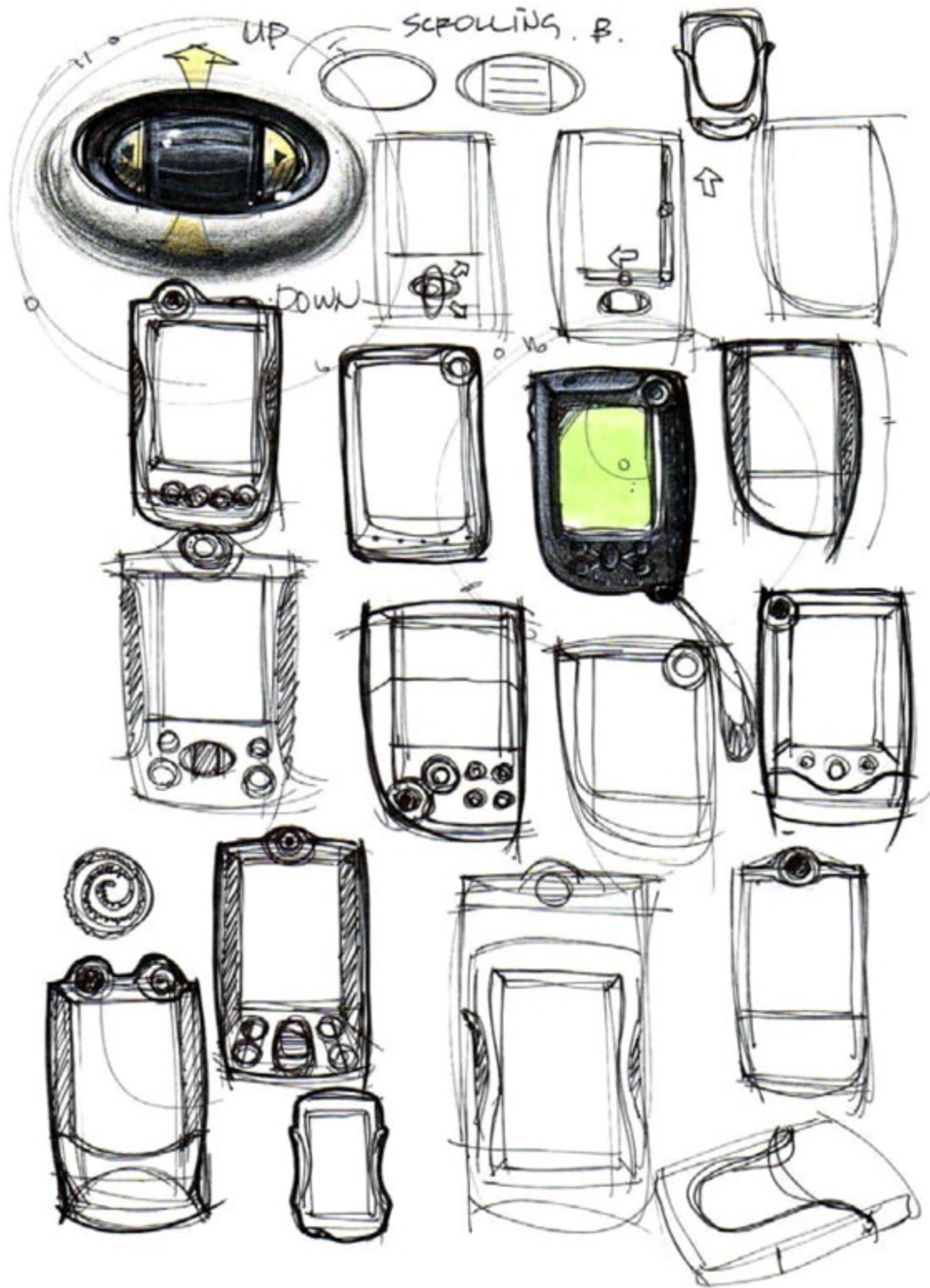

Roller wheel for up and down, two buttons for left and right. I was trying different options for a navigation disk.

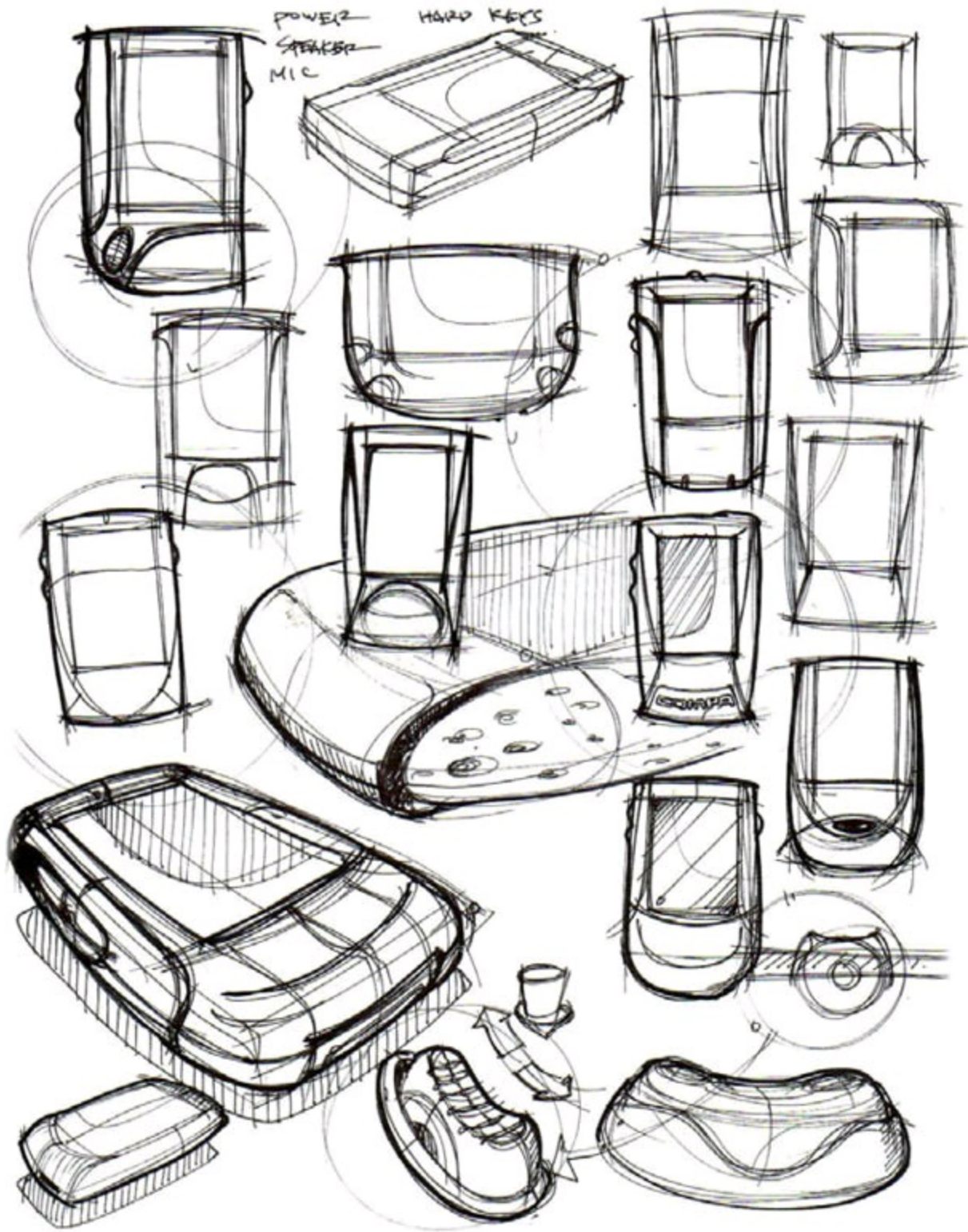

Asymmetrical design gives sporty feel. I think it would work for younger users.

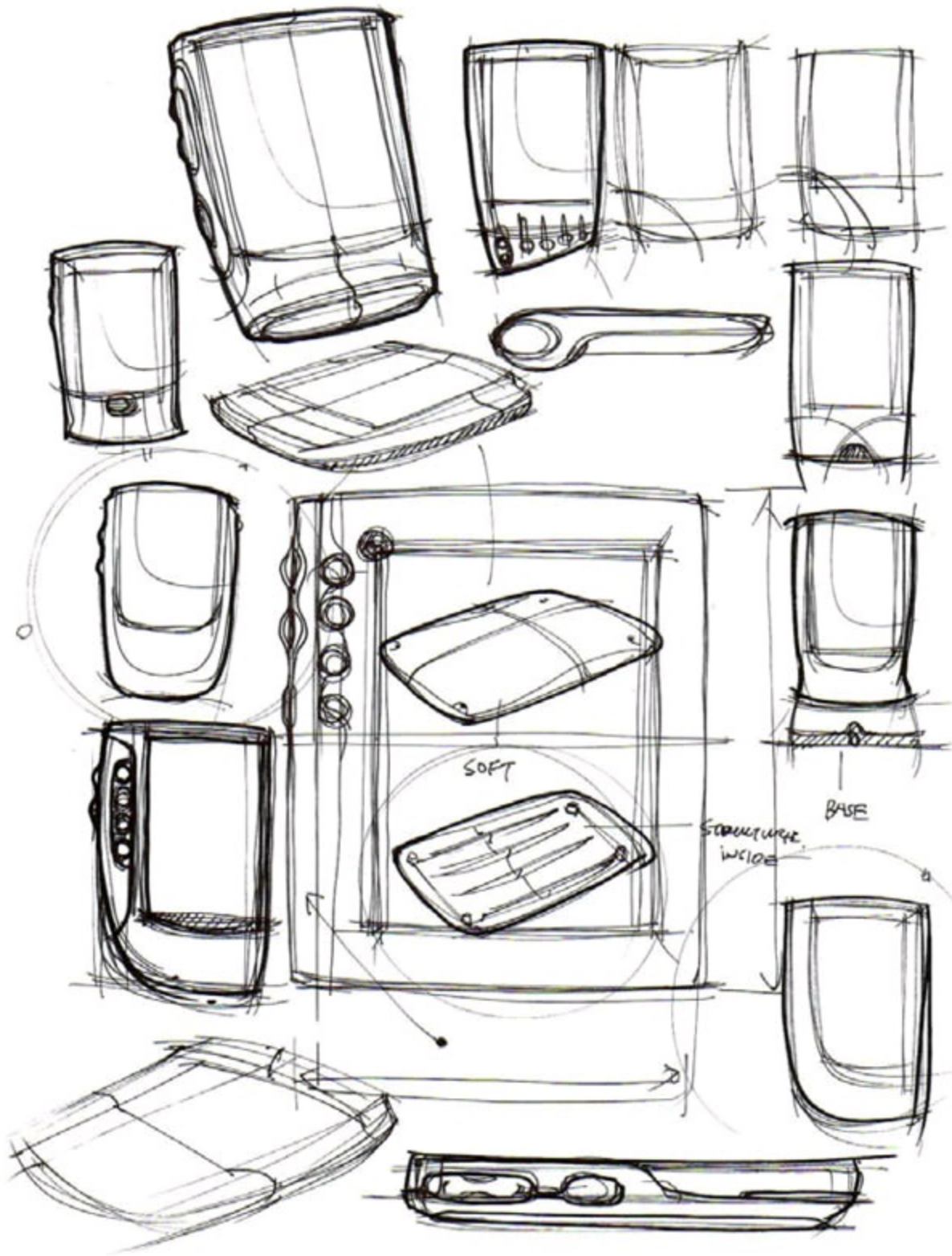

Corner key design to press keys from the front or the side of the device.



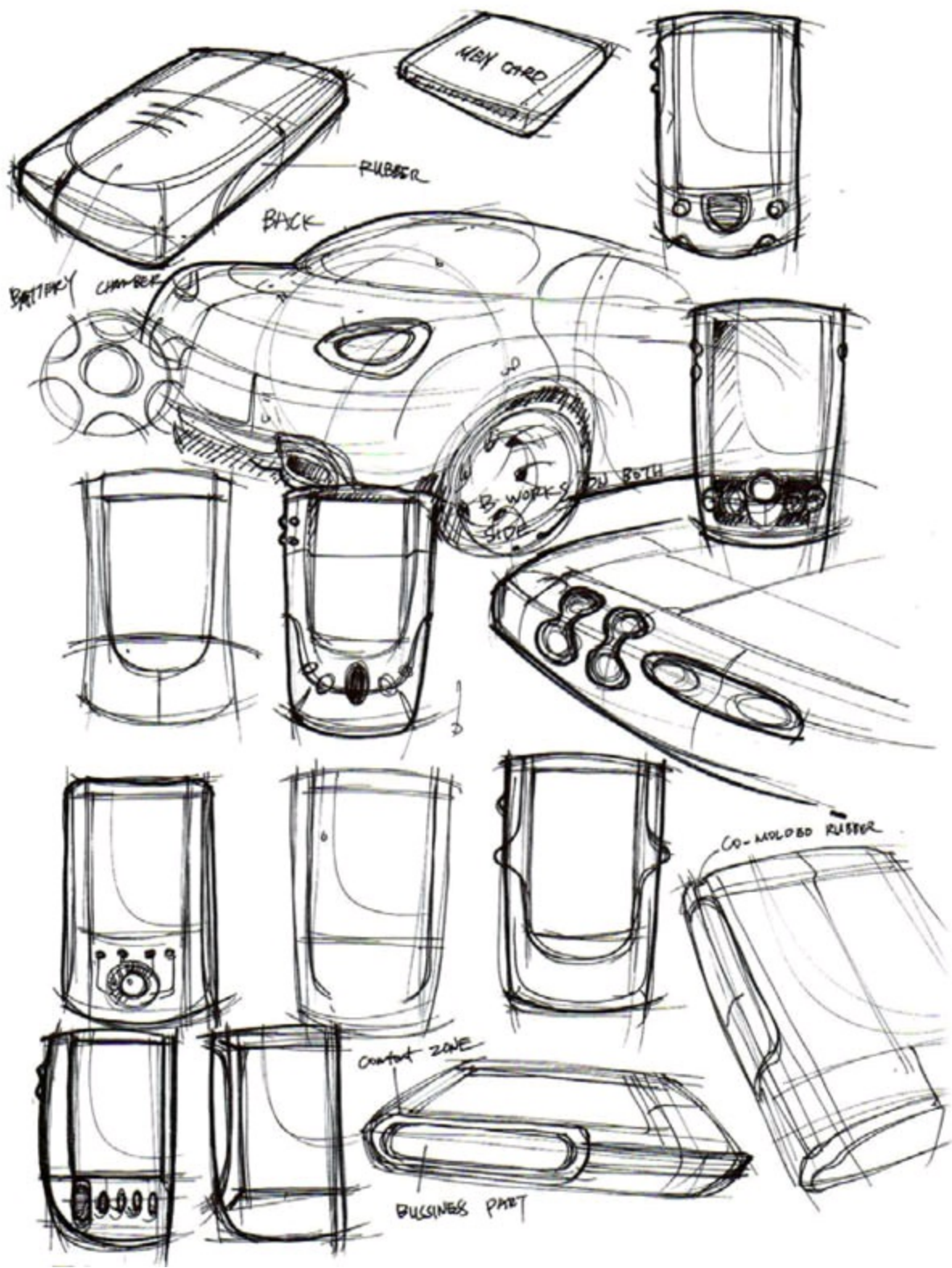

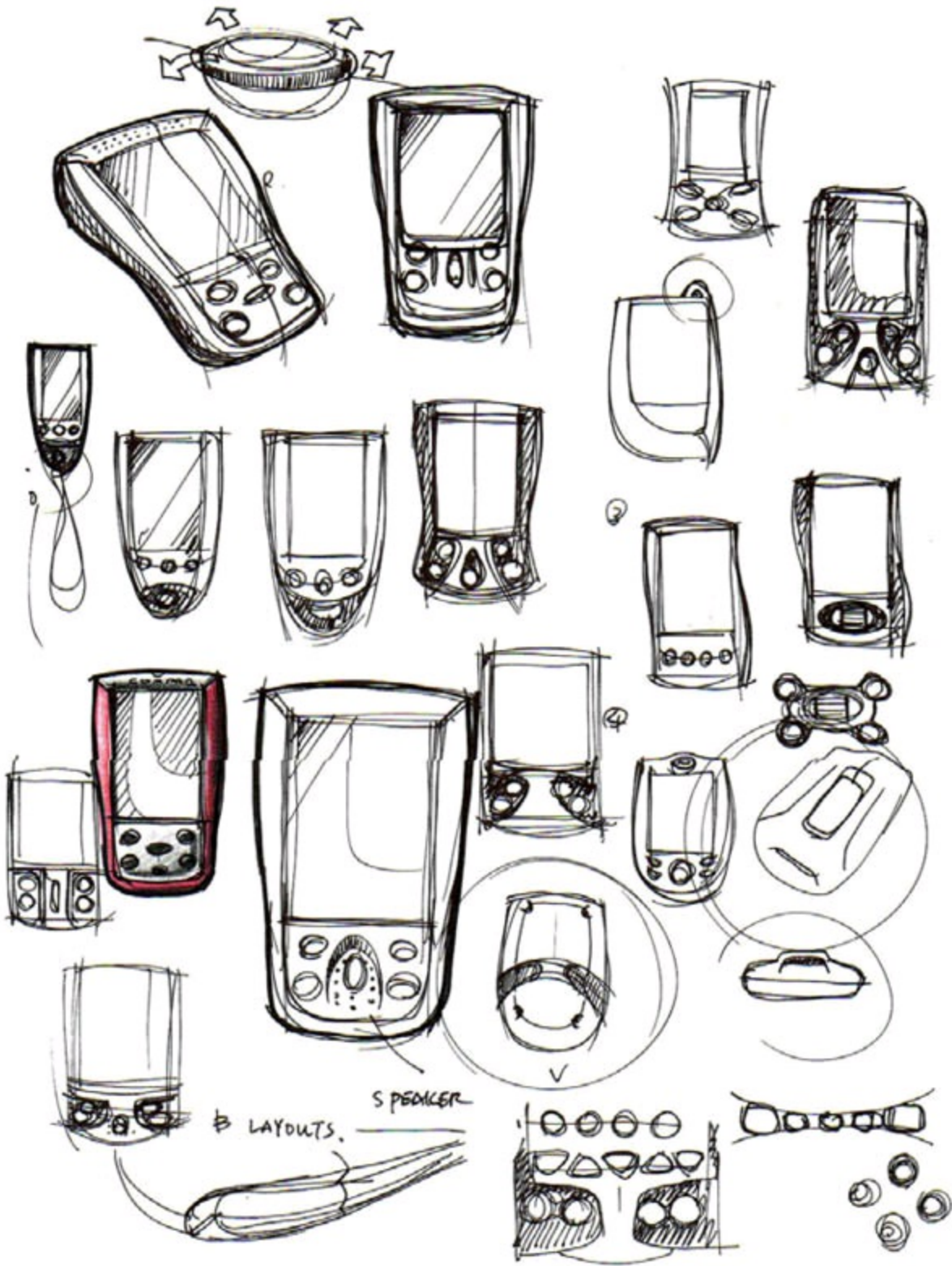

Rubberized or non-slipped finish for comfortable holding. Co-molding possibility for the device.

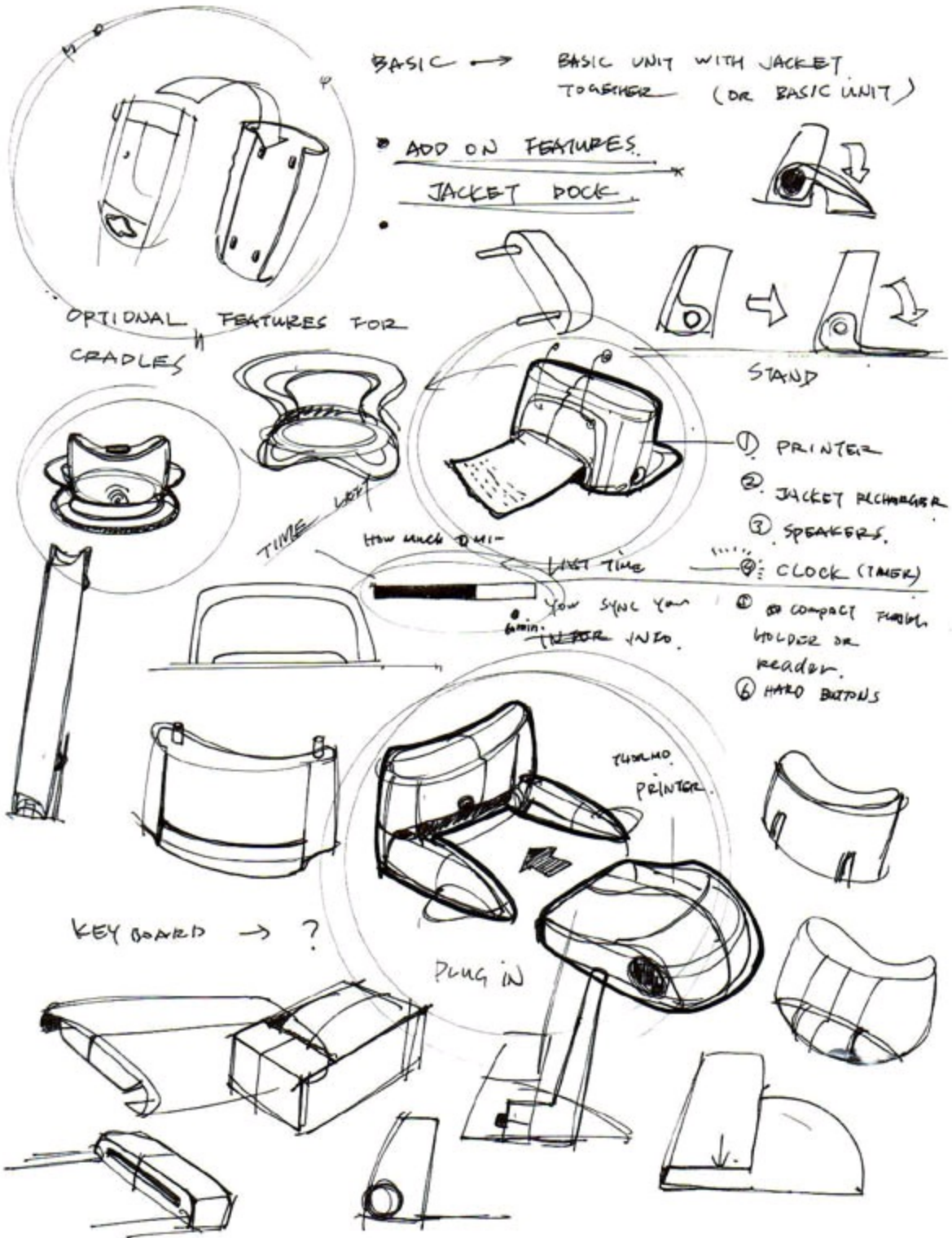

Built-in black and white thermo printer like a Game Boy. Write down notes for other design possibilities.

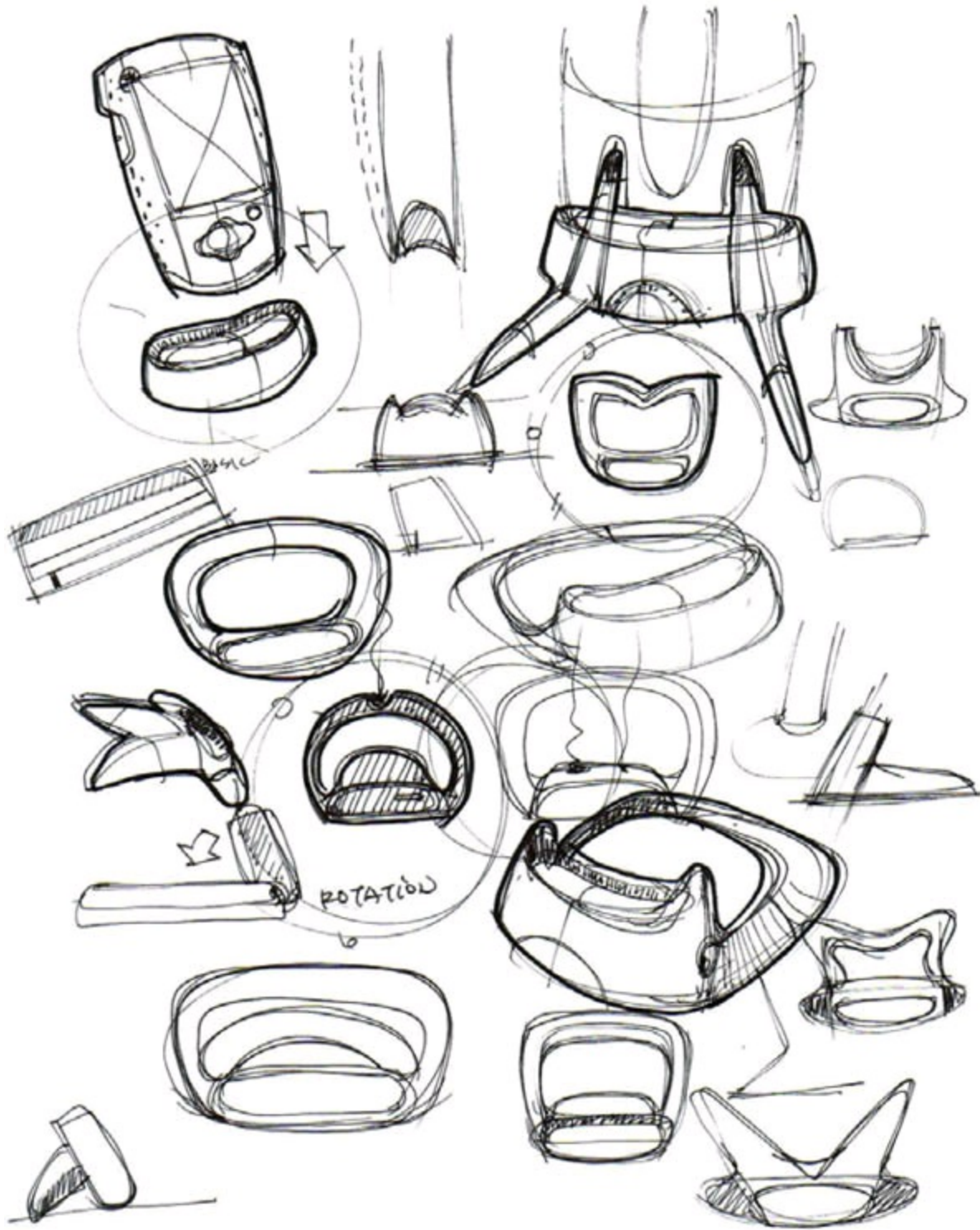

Original charger design. It seems to work with the final handheld PAD.

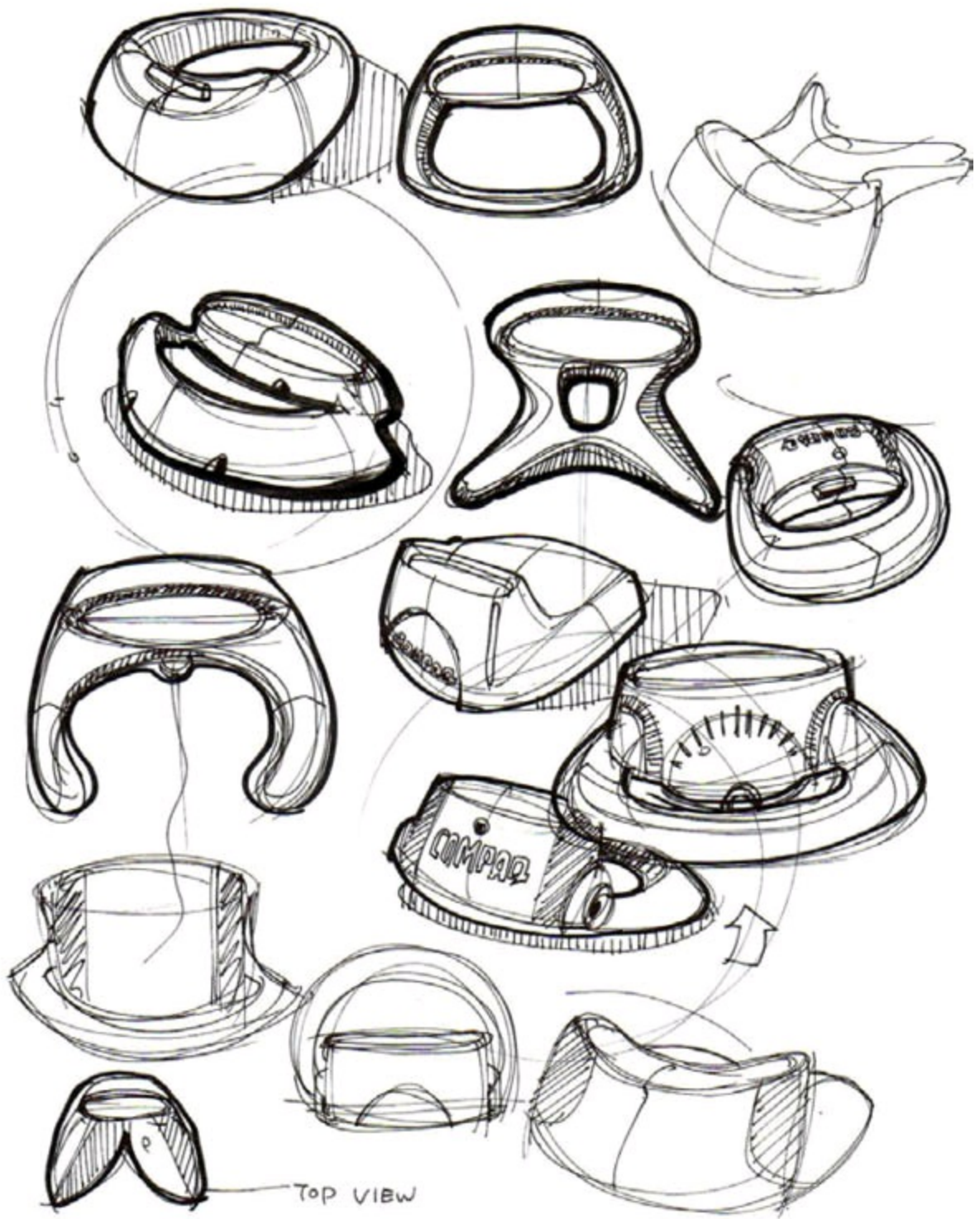

This one is working too. Up to this point, I thought I can narrow down the final cradle designs.

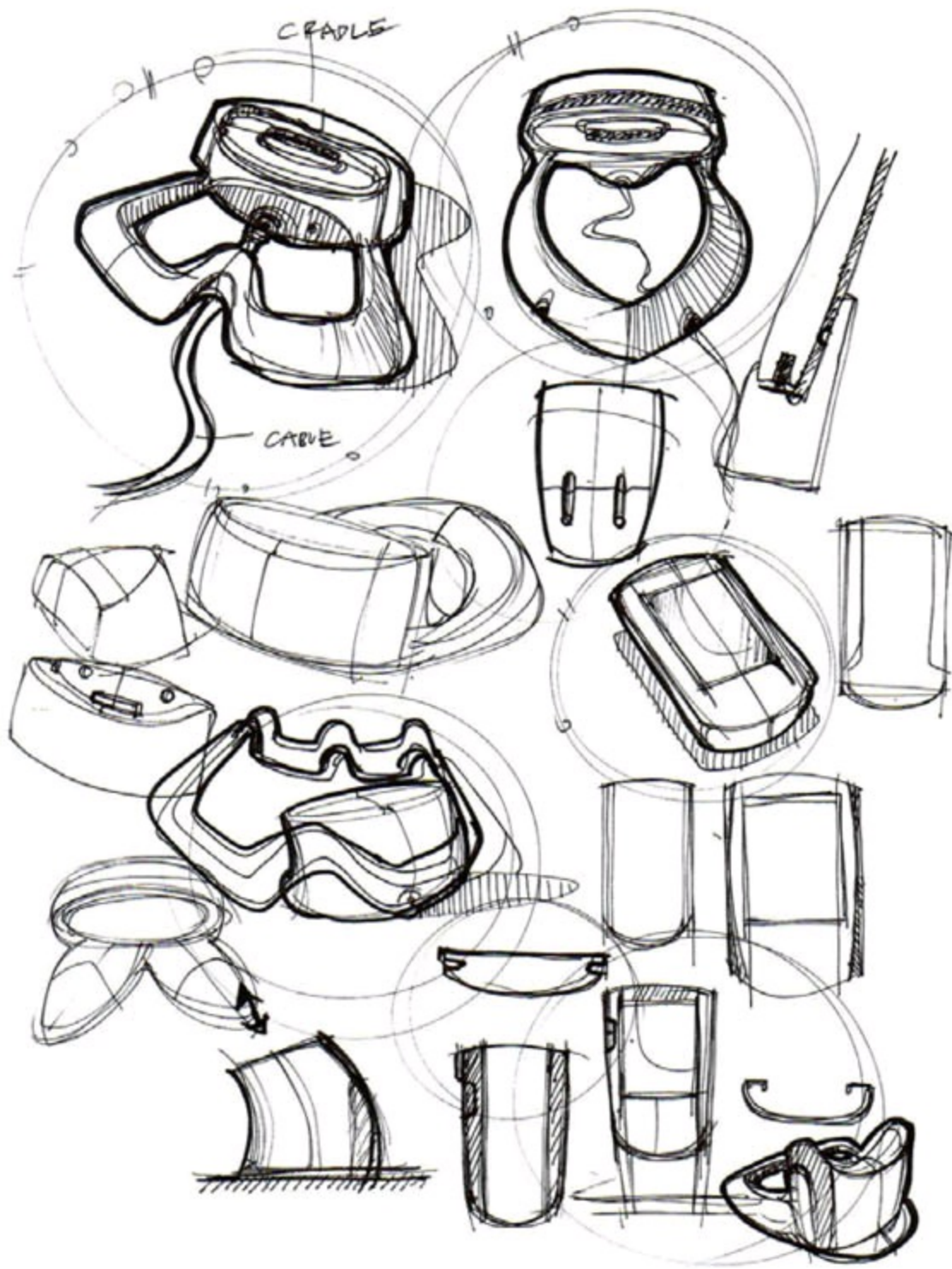

Getting closer to the final cradle design. Thinking about cable management.

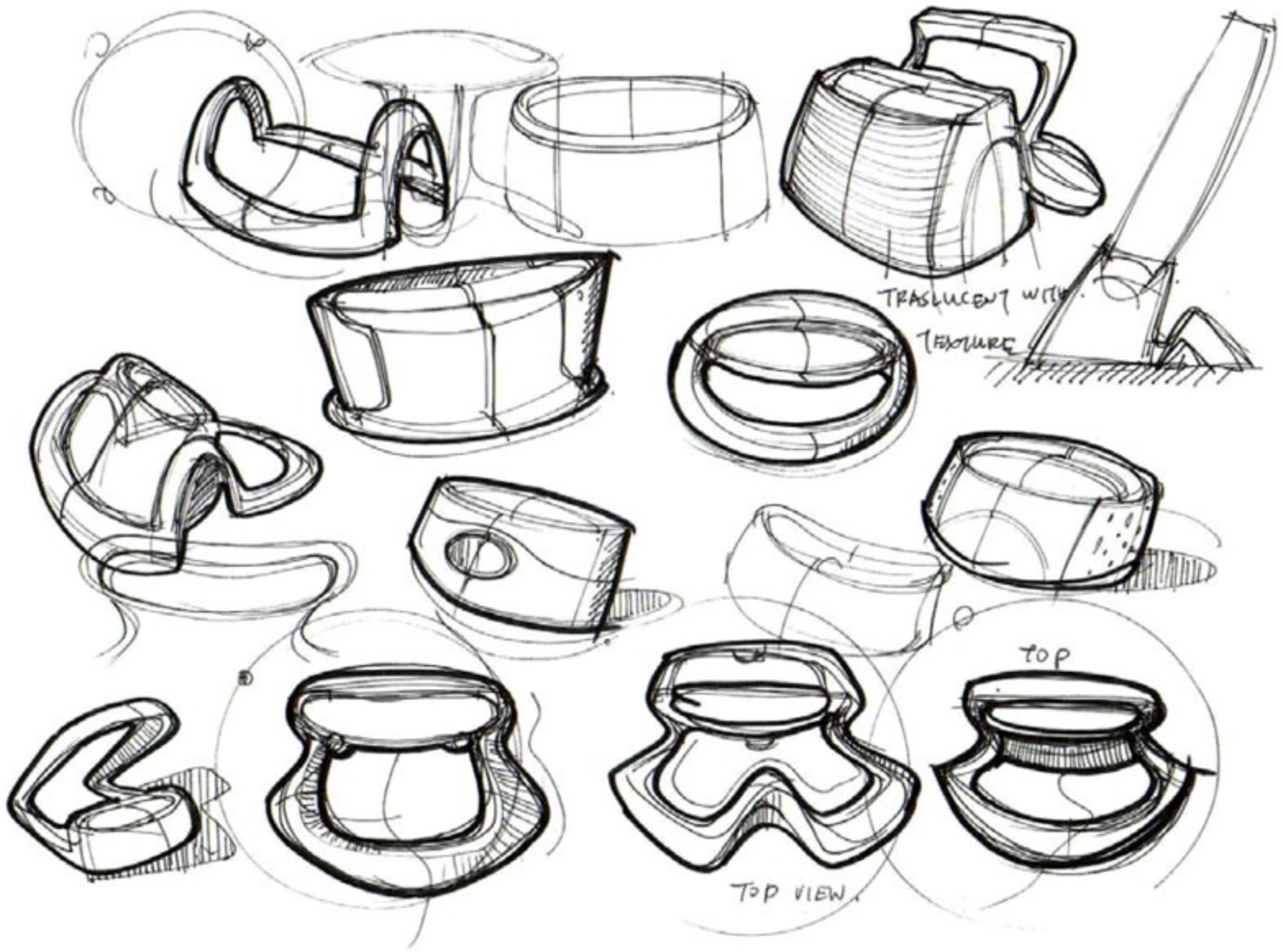

Interesting cradle design. I might save it for another concept.

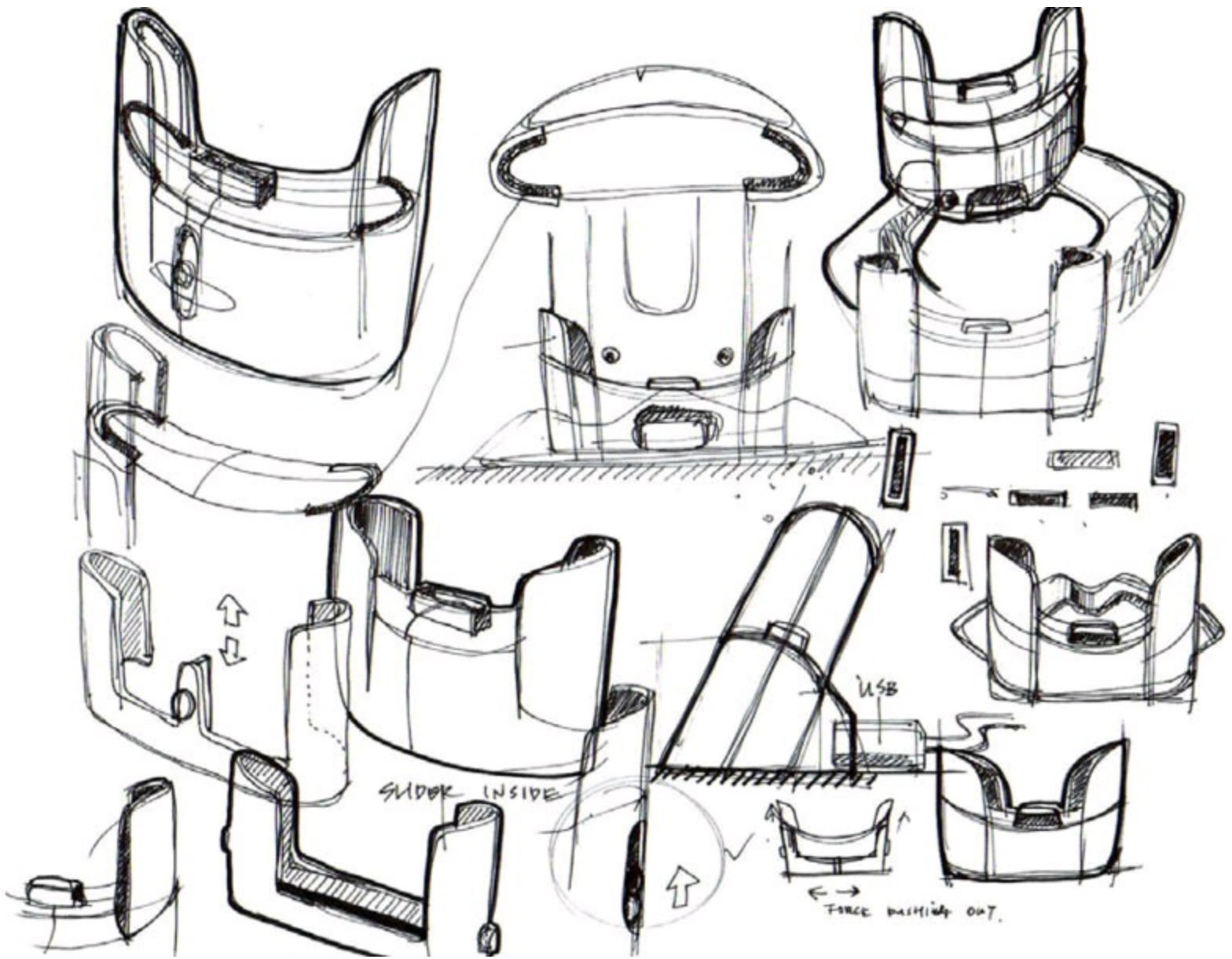

Potential mechanism for the inside slider. To compensate the thickness of the jacket, a moving holder was created.



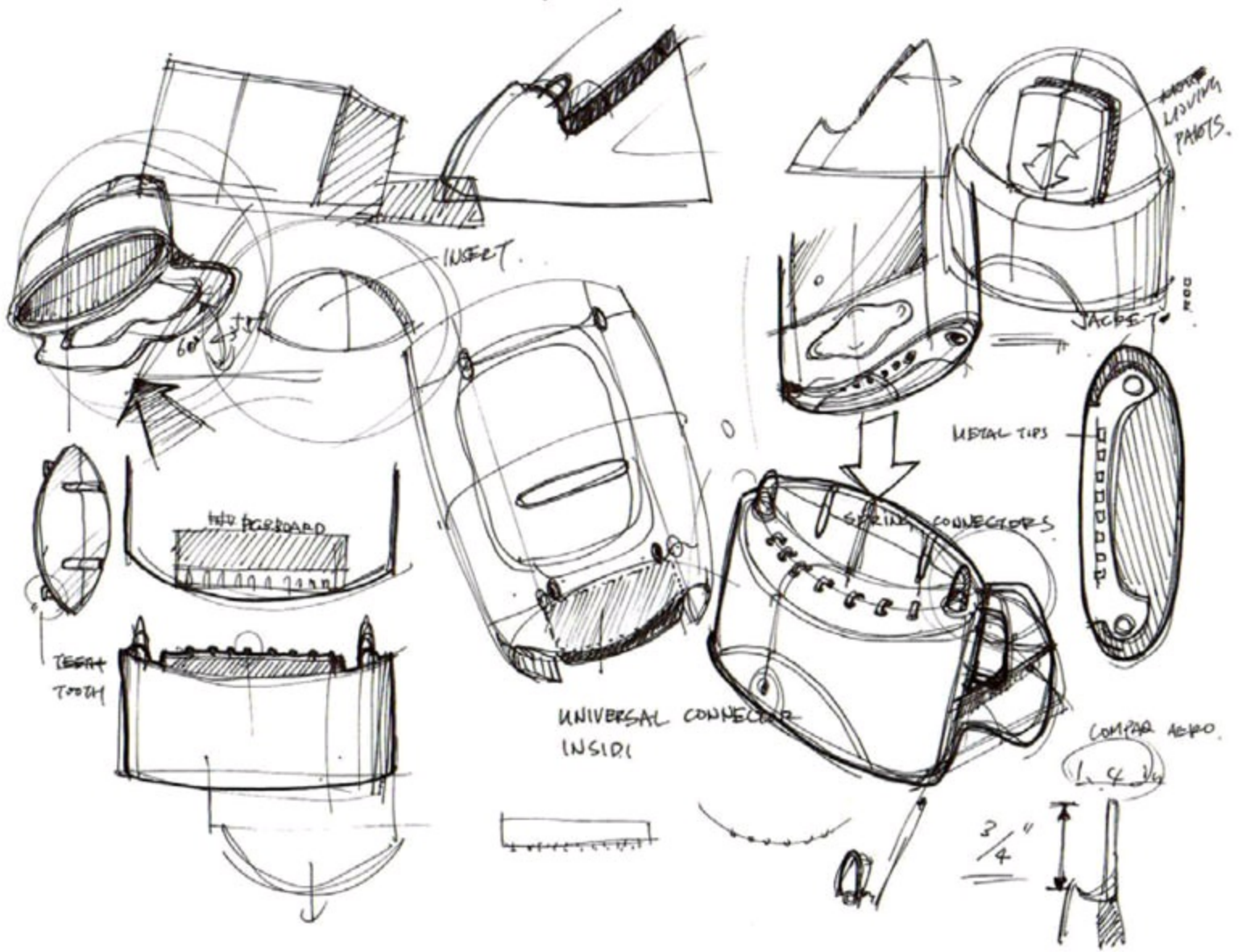

I wanted to have a separated connector for power and data so that would be convenient while traveling without carrying the cradle. I proposed to use gold finger type connector instead of pin type connector. It would look clean.

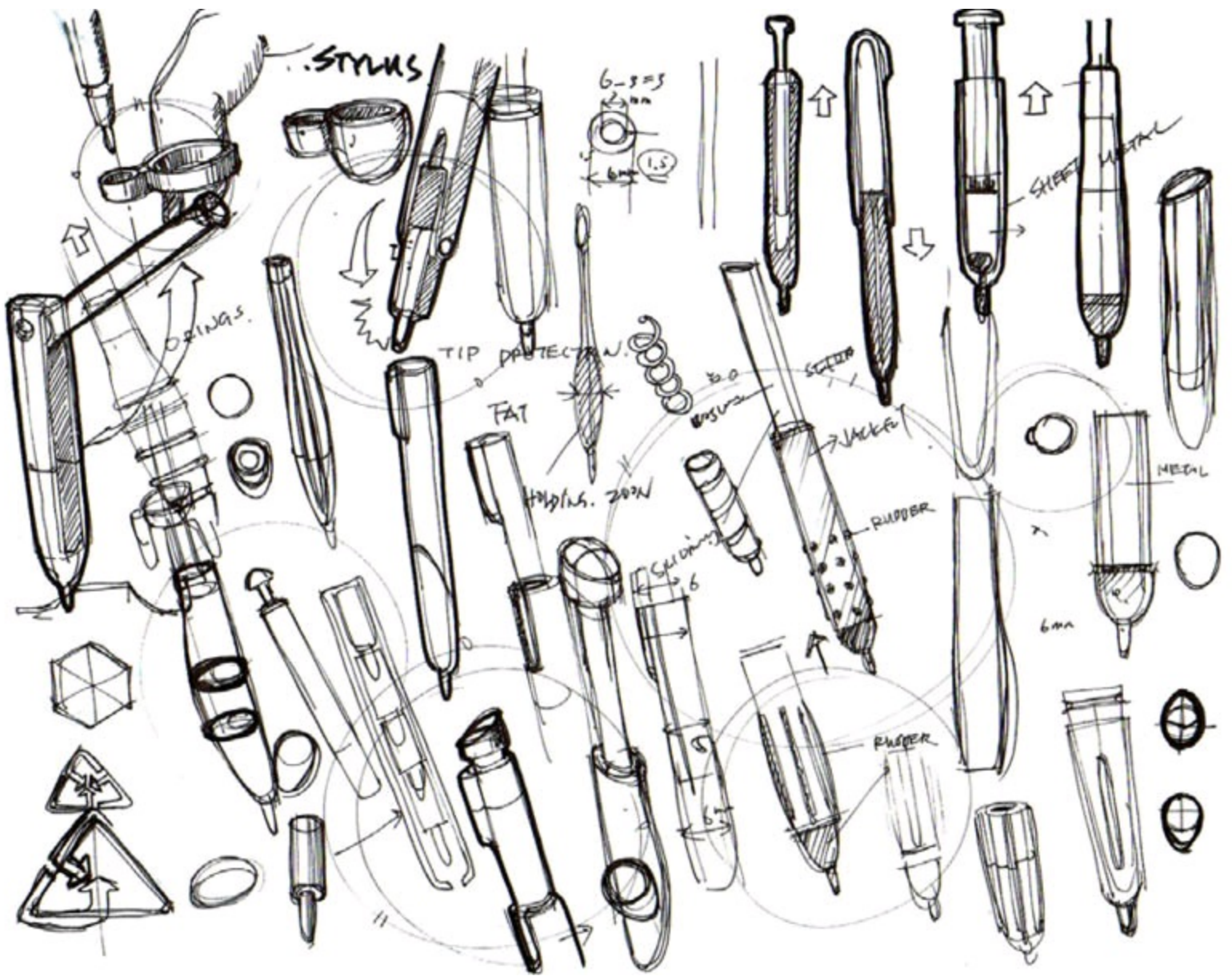

Finger stylus design, it did not work for the iPaq but it could be an interesting accessory. To fight for a tight internal space, spring loaded stylus with extension was one of the solution.

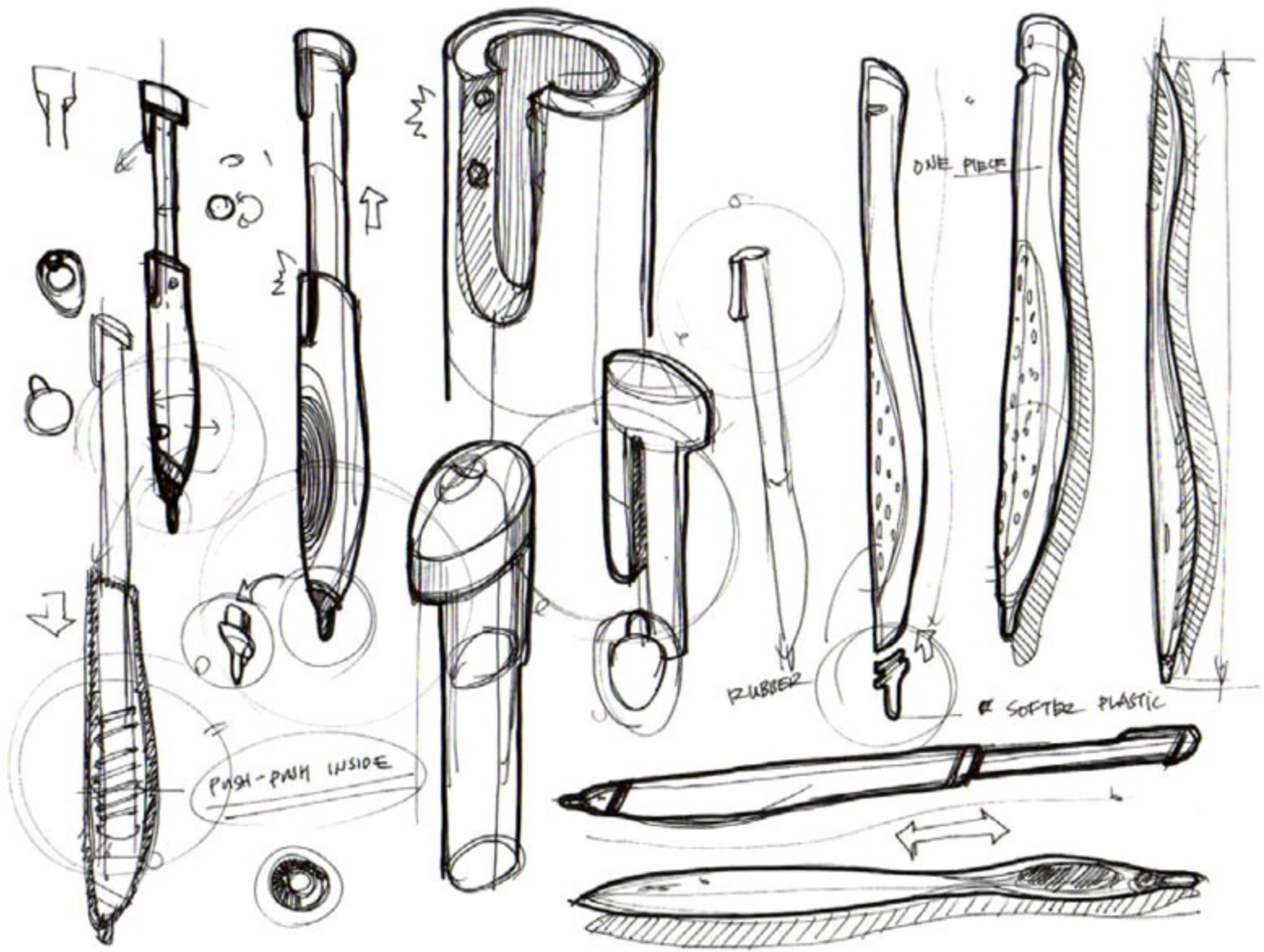

Telescoping structure for reducing the length of the stylus.

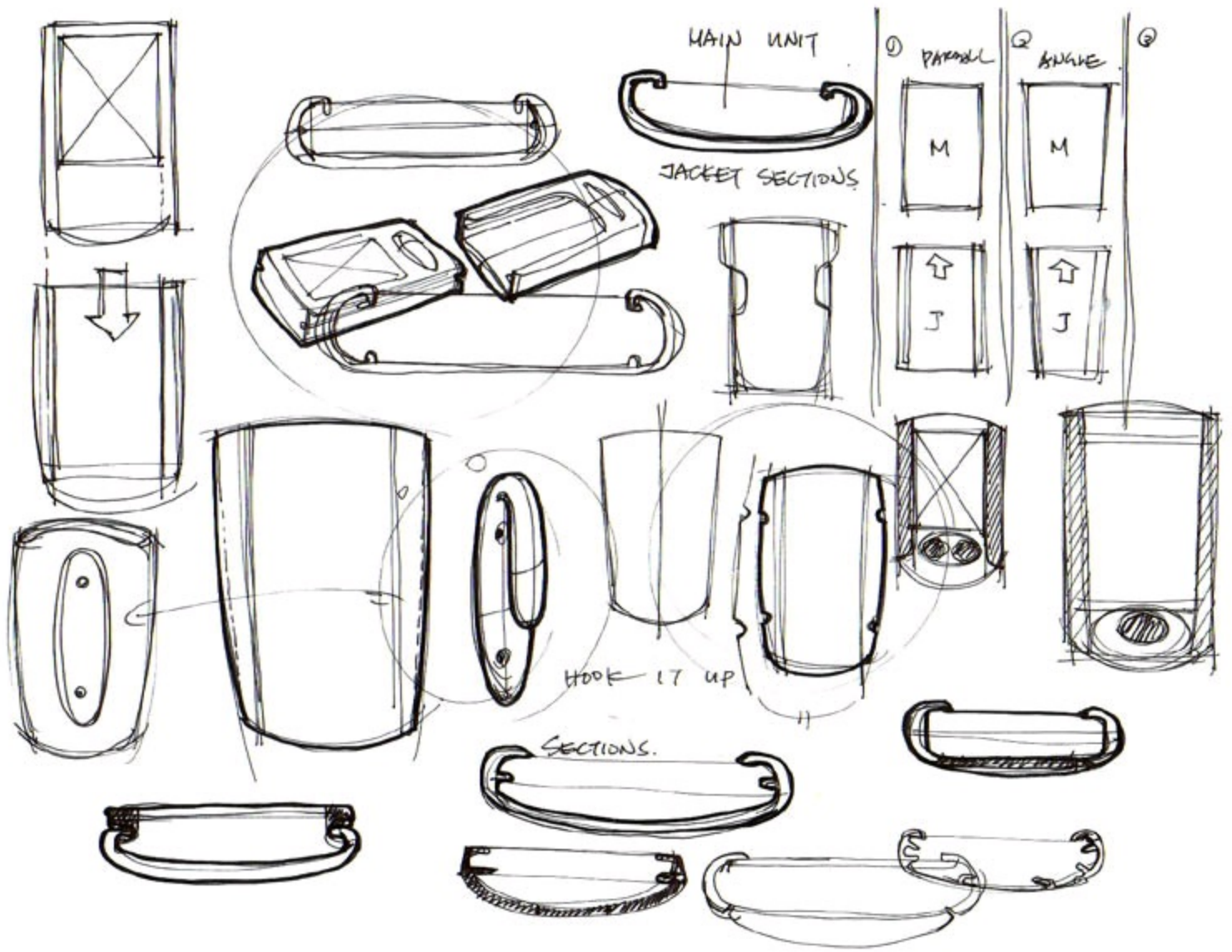

Co-molded rubber grip and tip for stylus design.

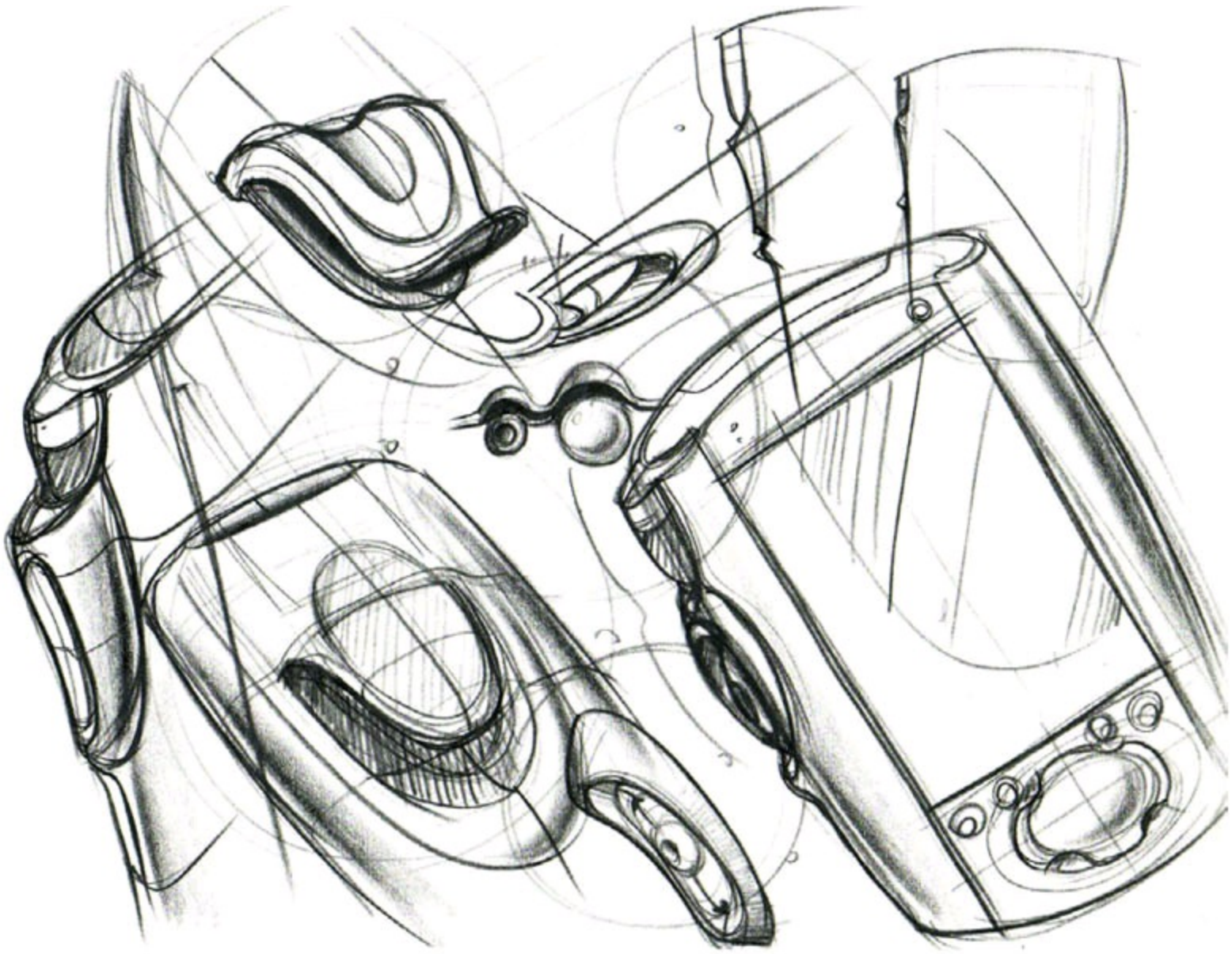

Optional belt clip design on basic Jacket.

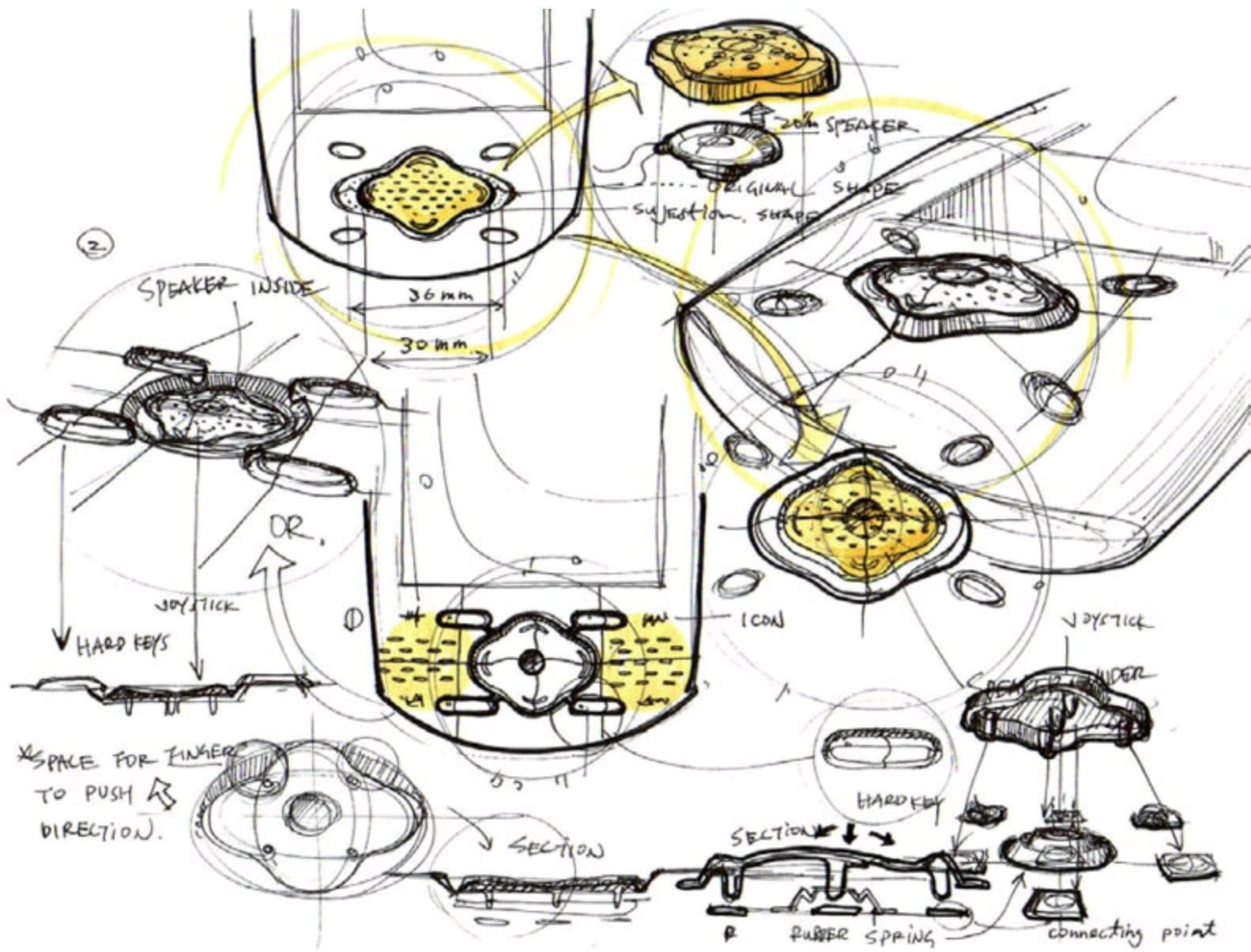

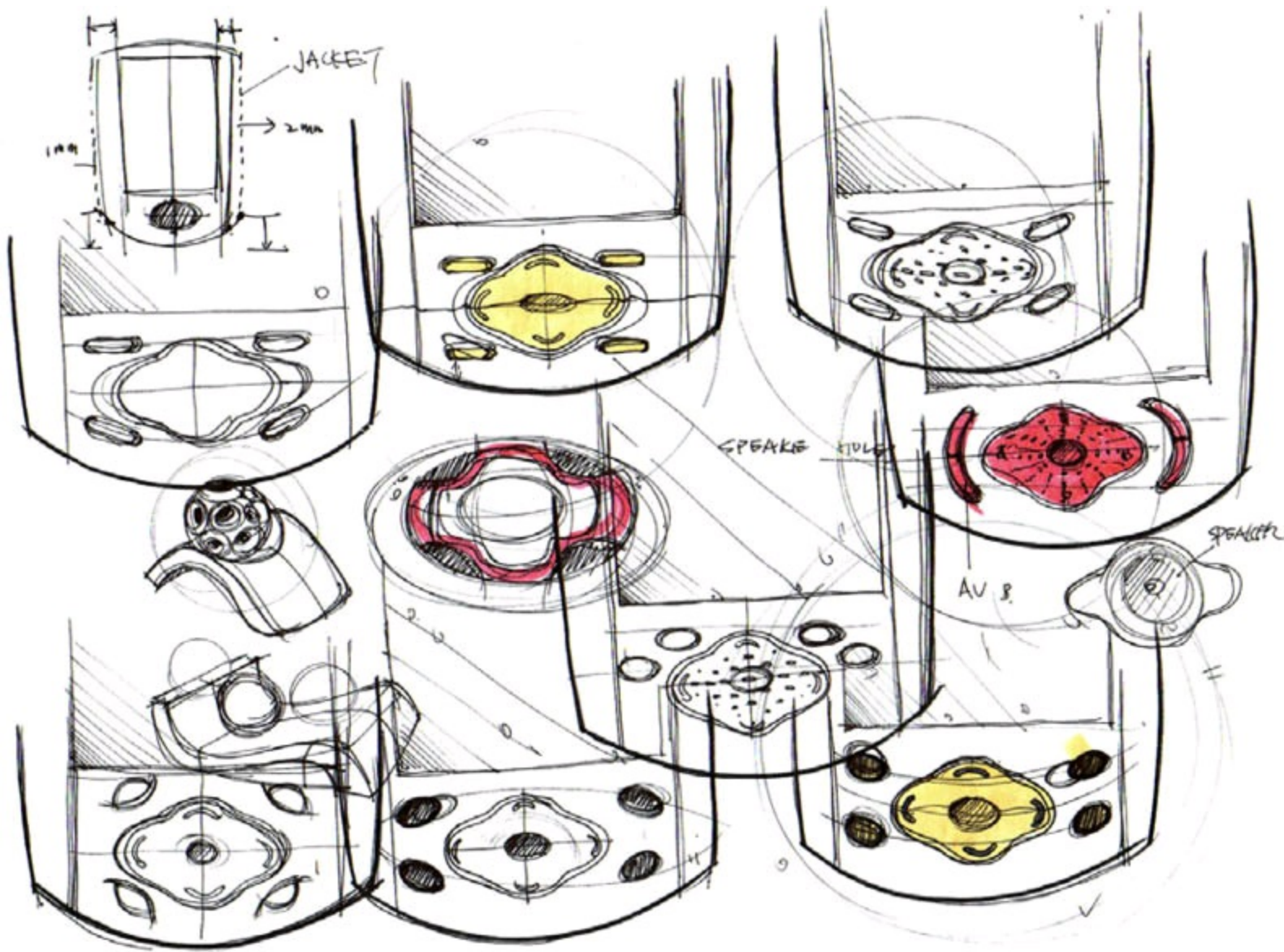

Structure imagination of 5-way navigation + load speaker. I came out the idea because the components did not fit in a limit space.

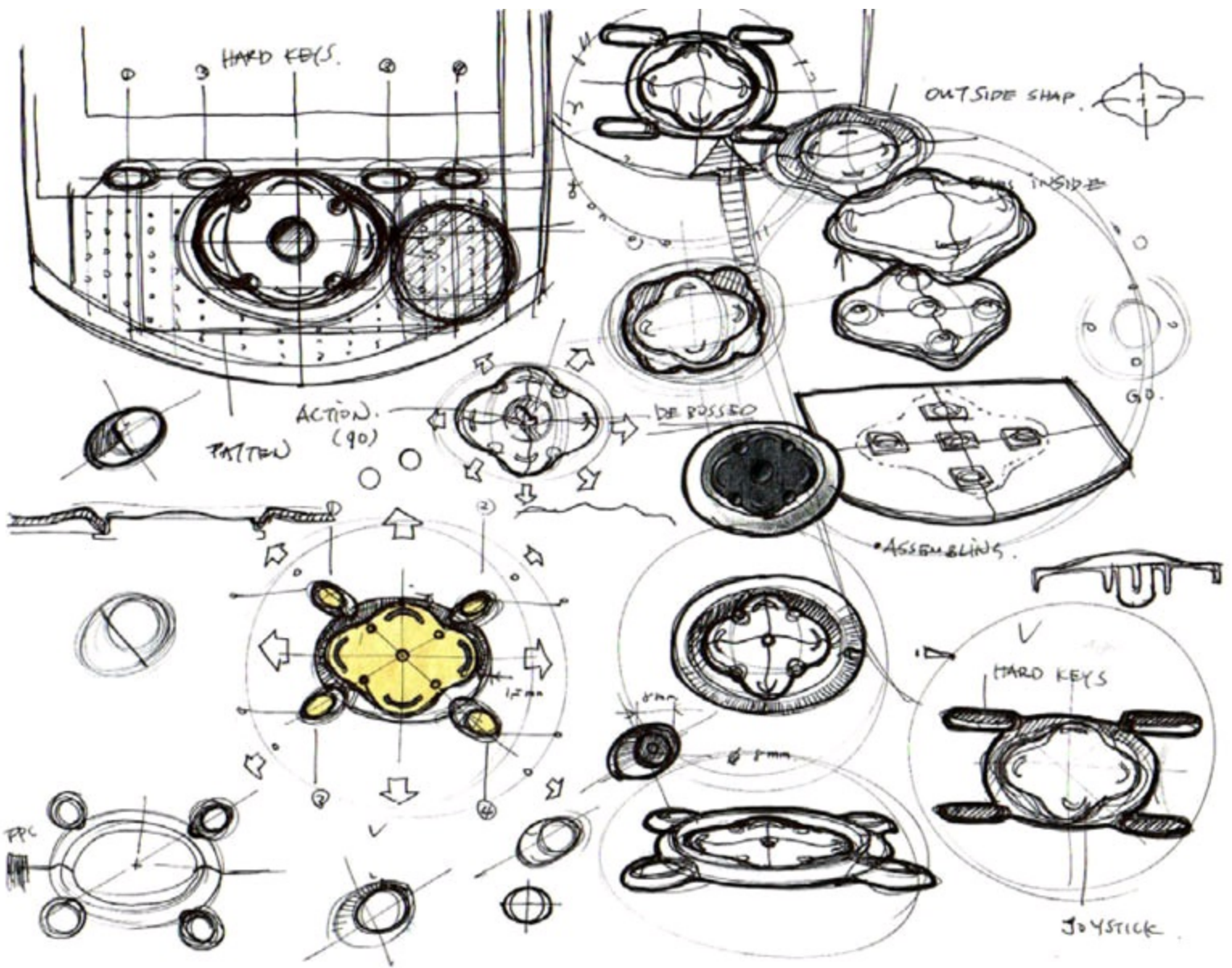

Explored view of 5-way navigation.



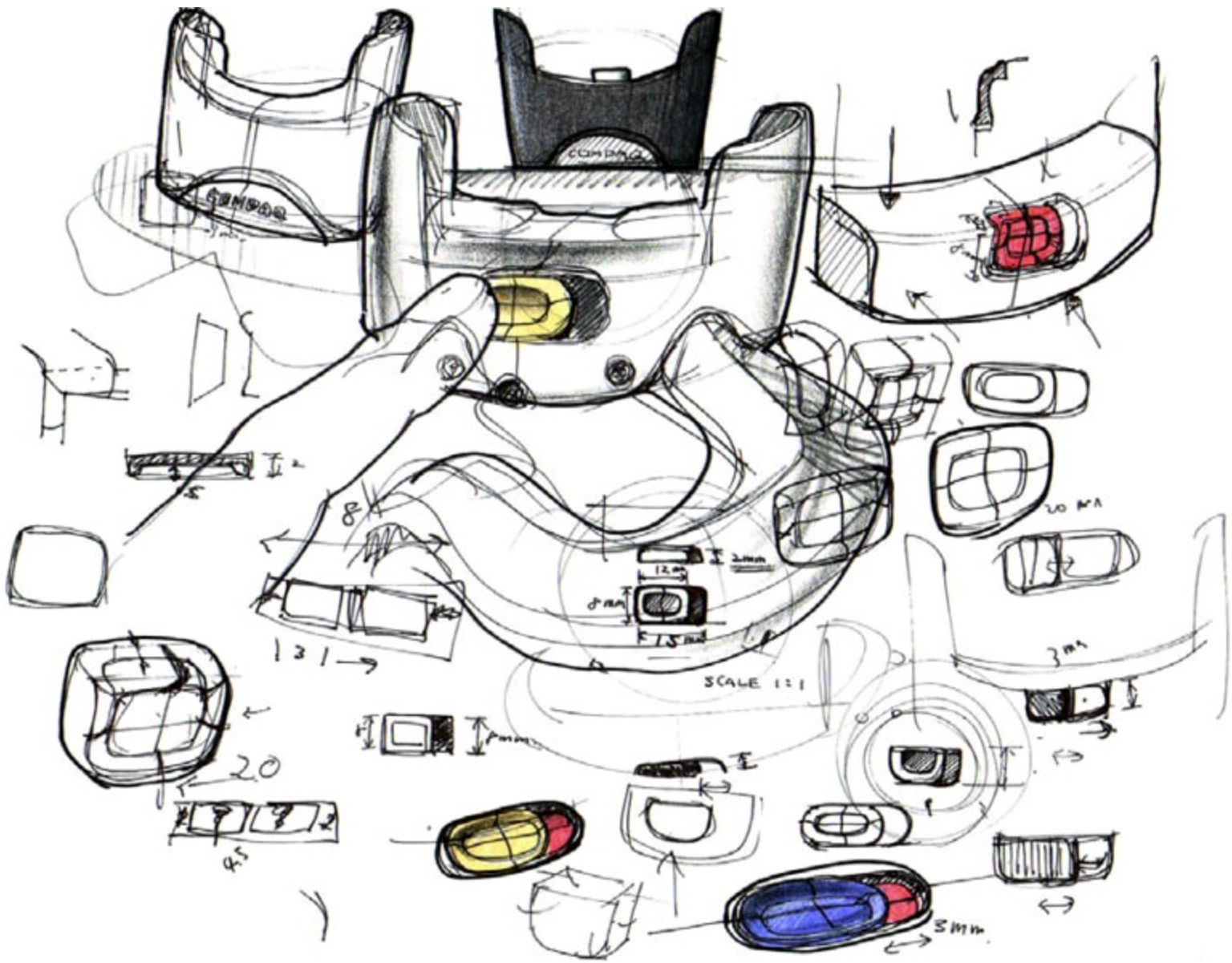

Design a switch for an adjustable sliding holder. Left- iPaq with Jacket. Right- iPaq without jacket.

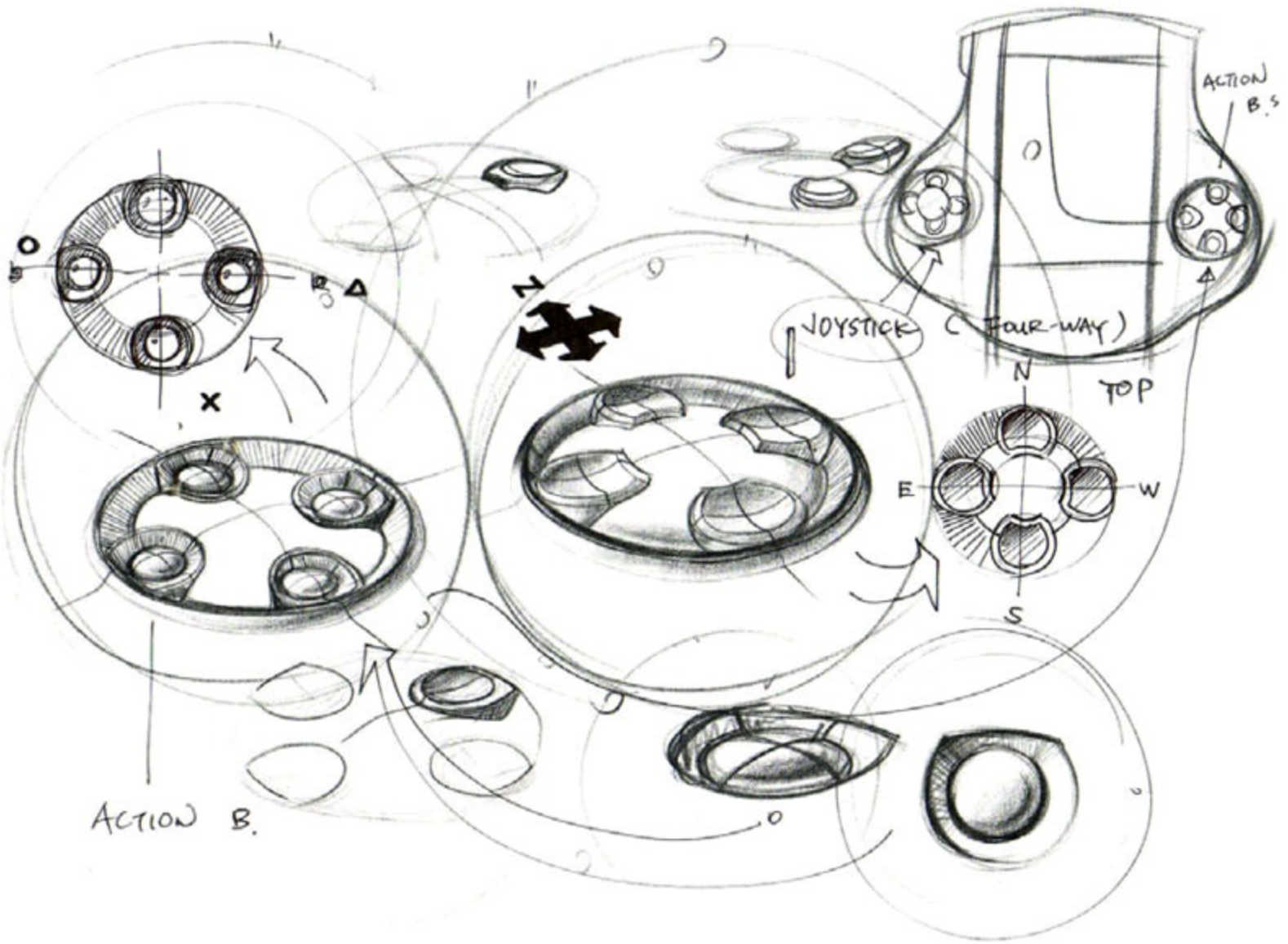

Button designs for gamer jacket. Need to make models and try it if the design worked.

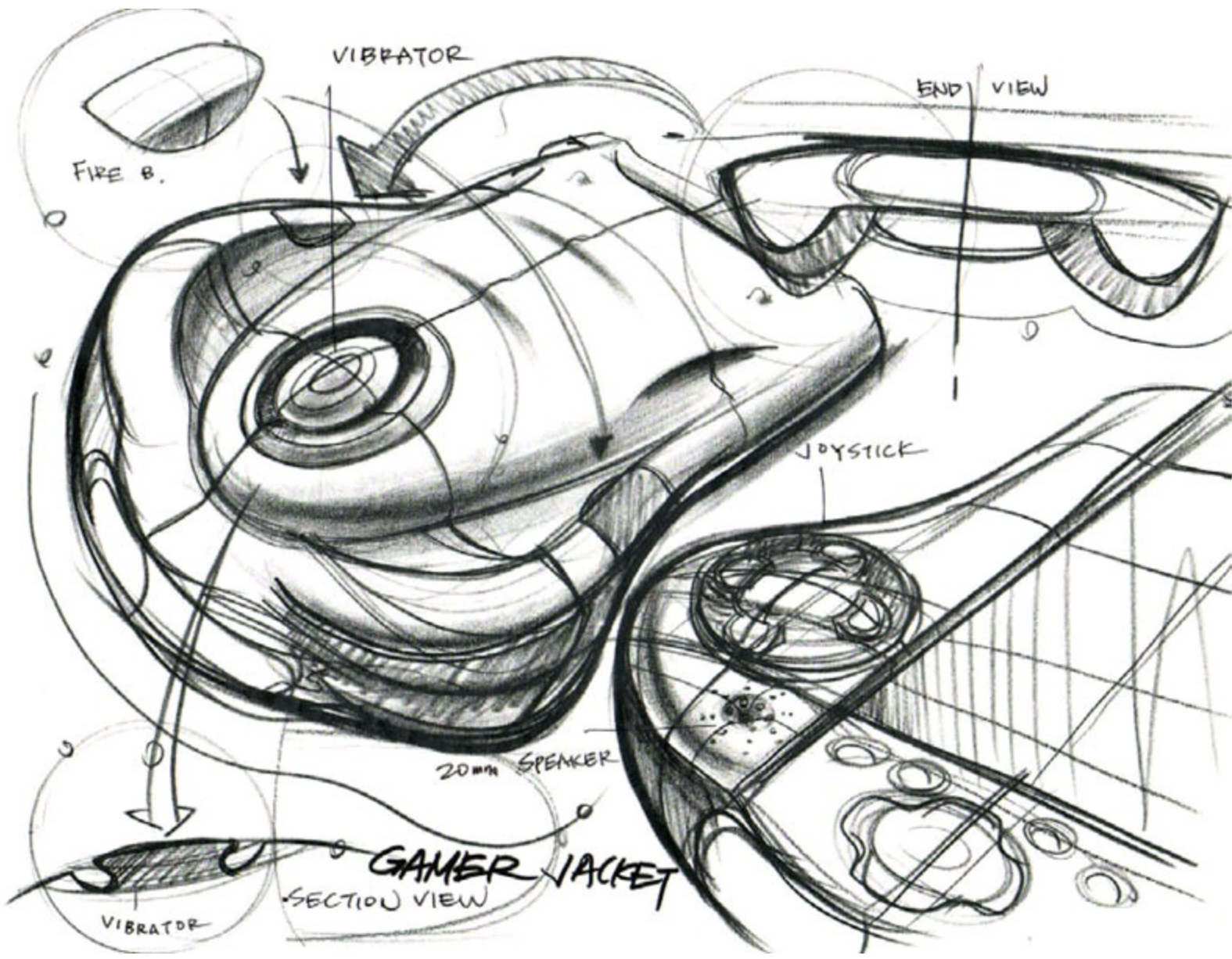

A built-in vibrator to enhance gaming experience.



Concepts for internal review

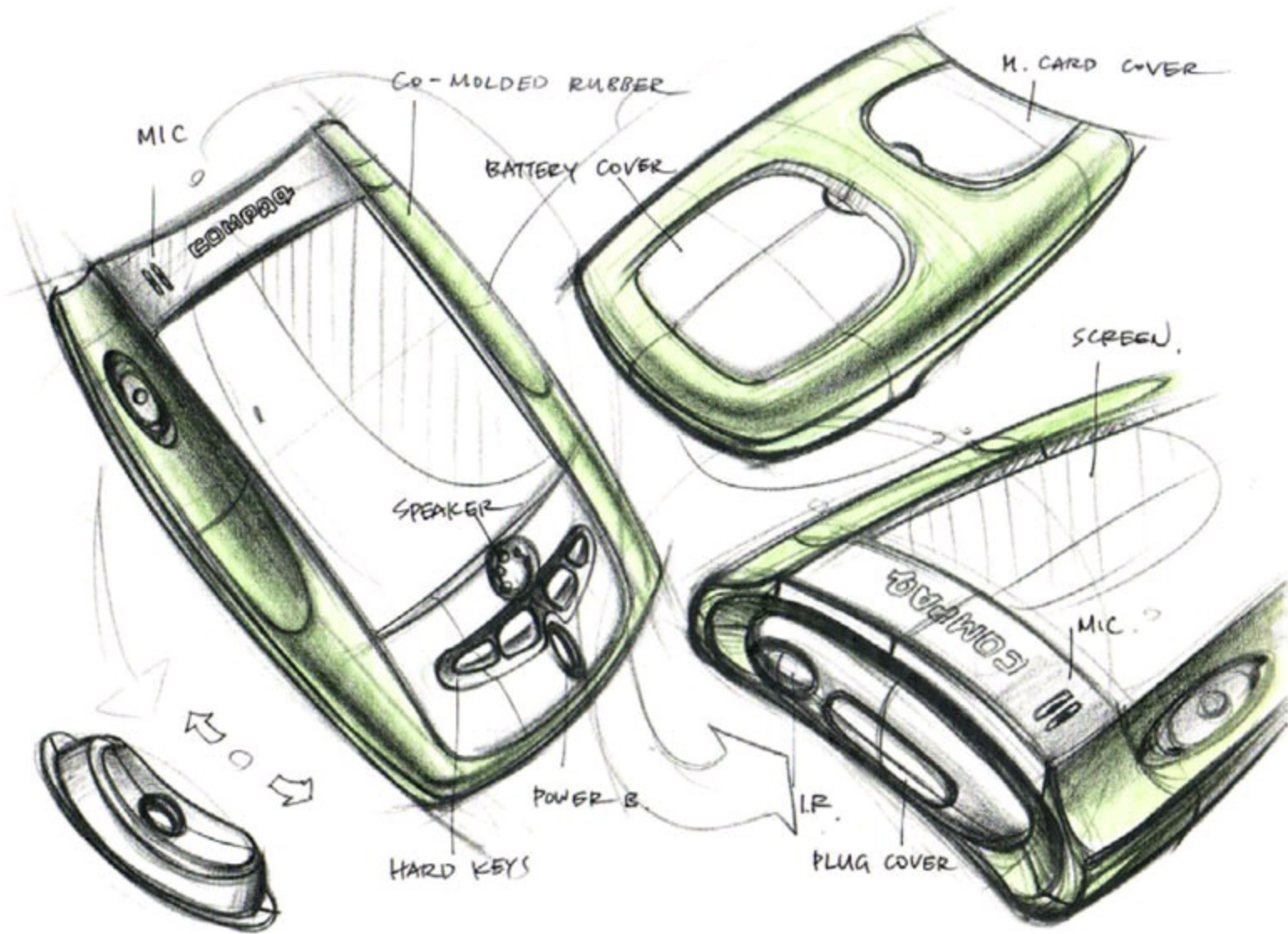

Concepts for internal review

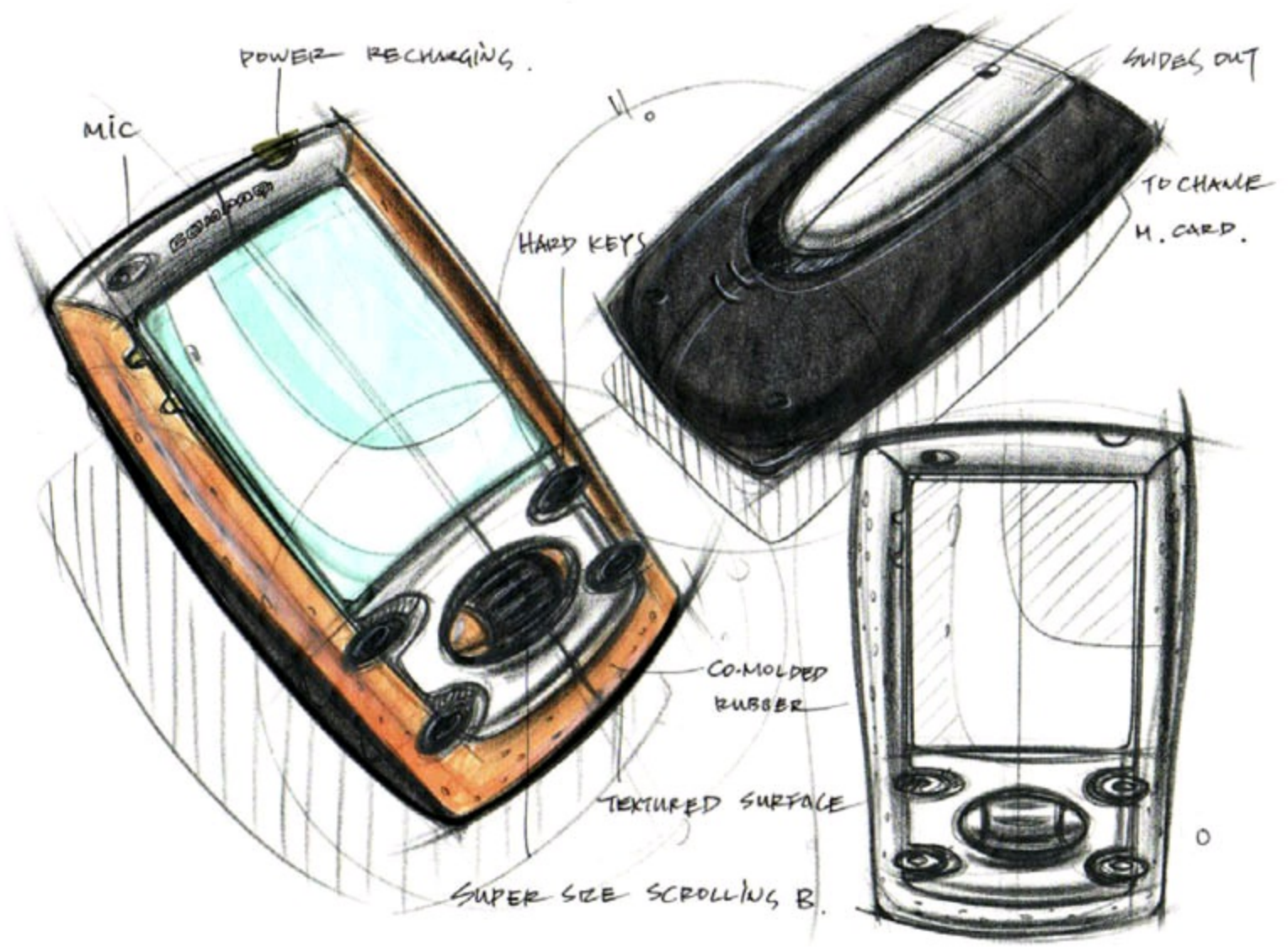

Concepts for internal review

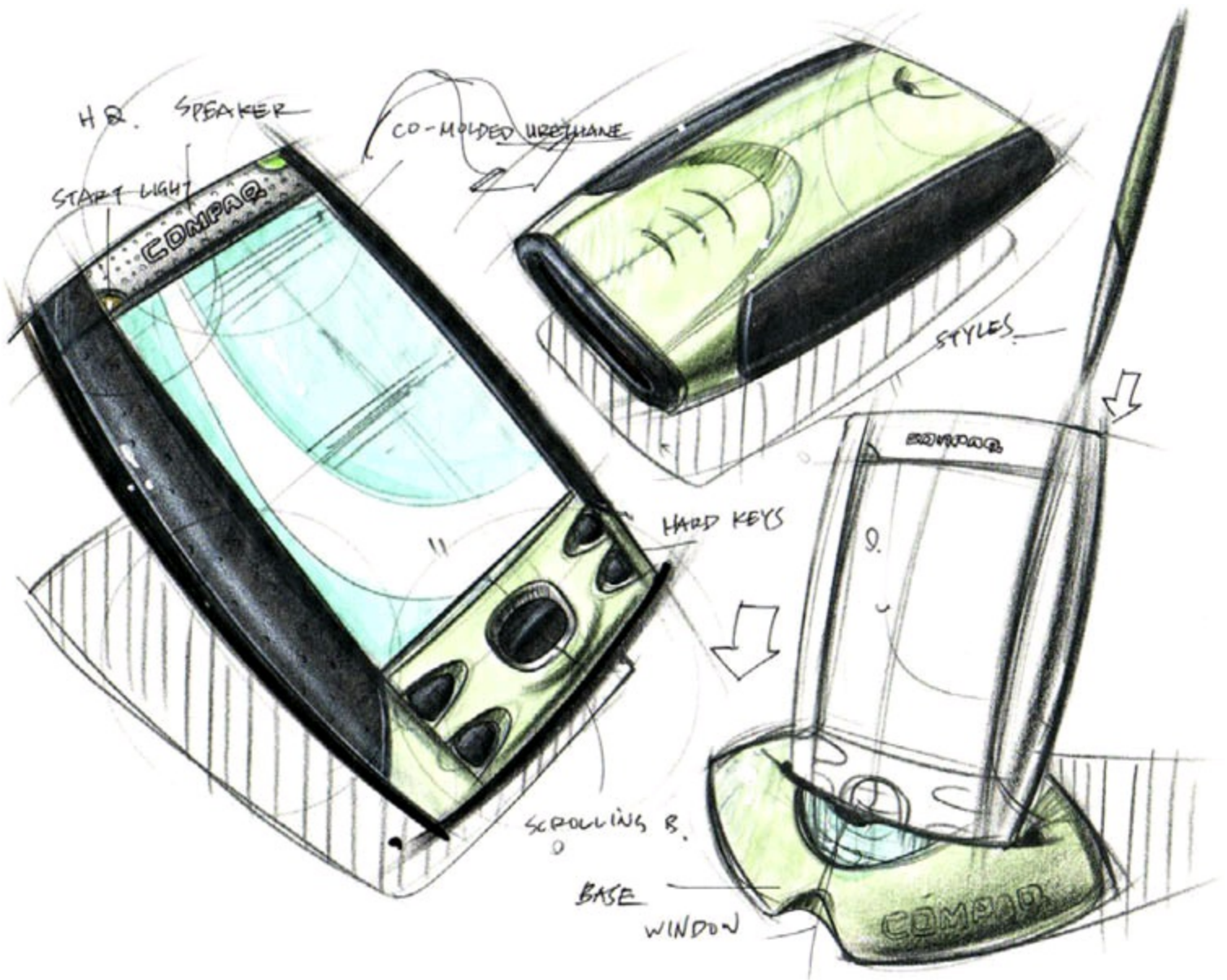

Concepts for internal review

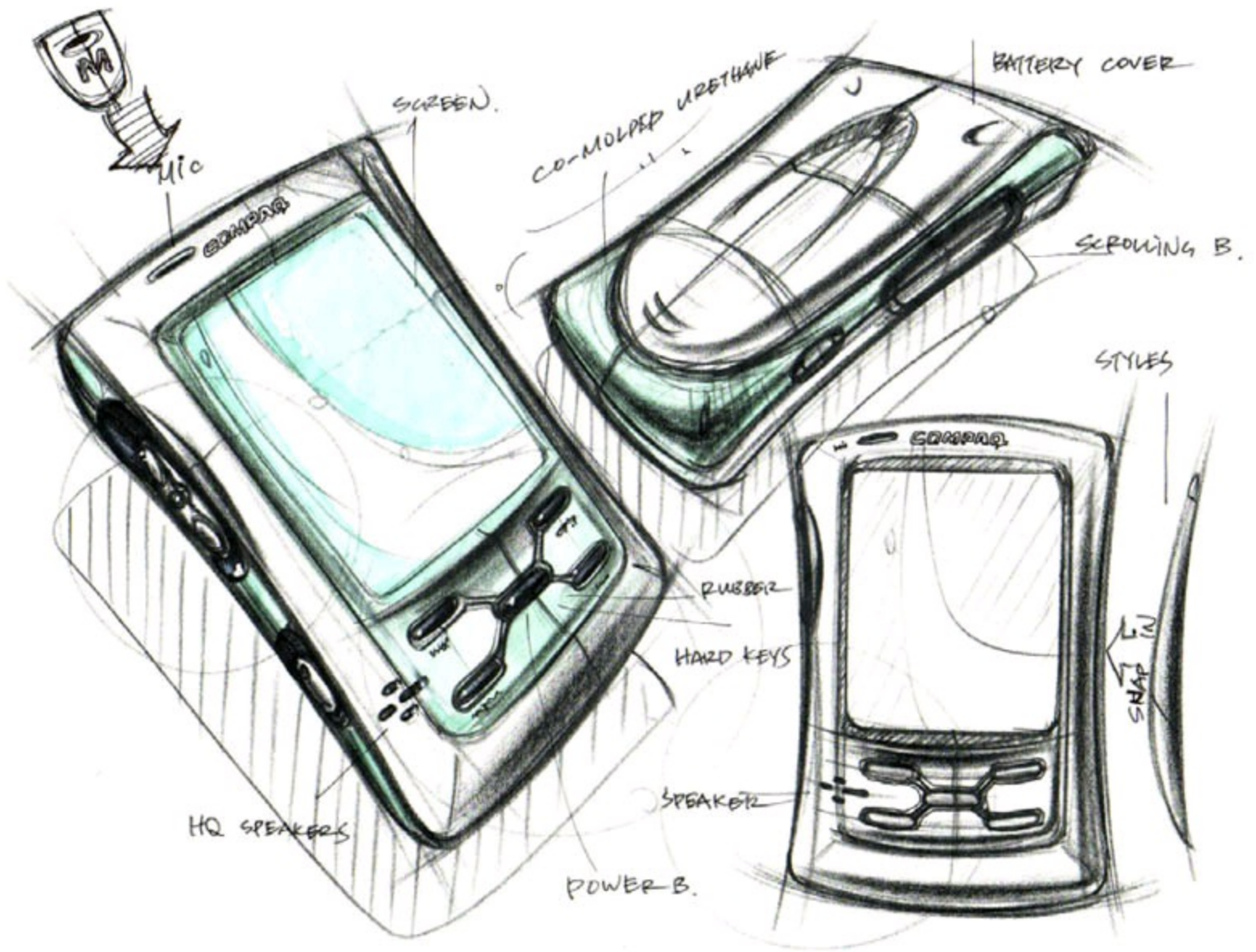

Concepts for internal review



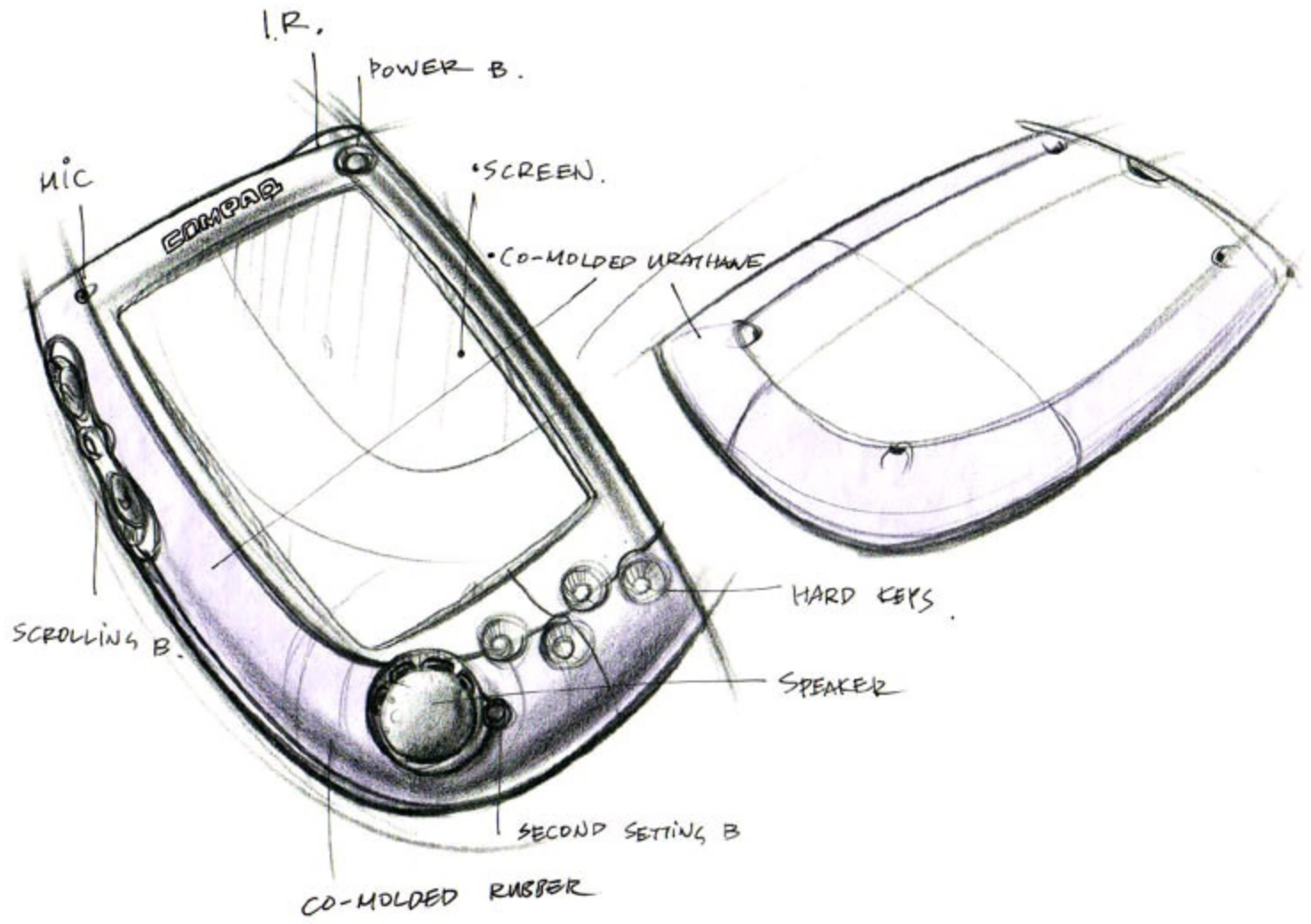

Concepts for internal review

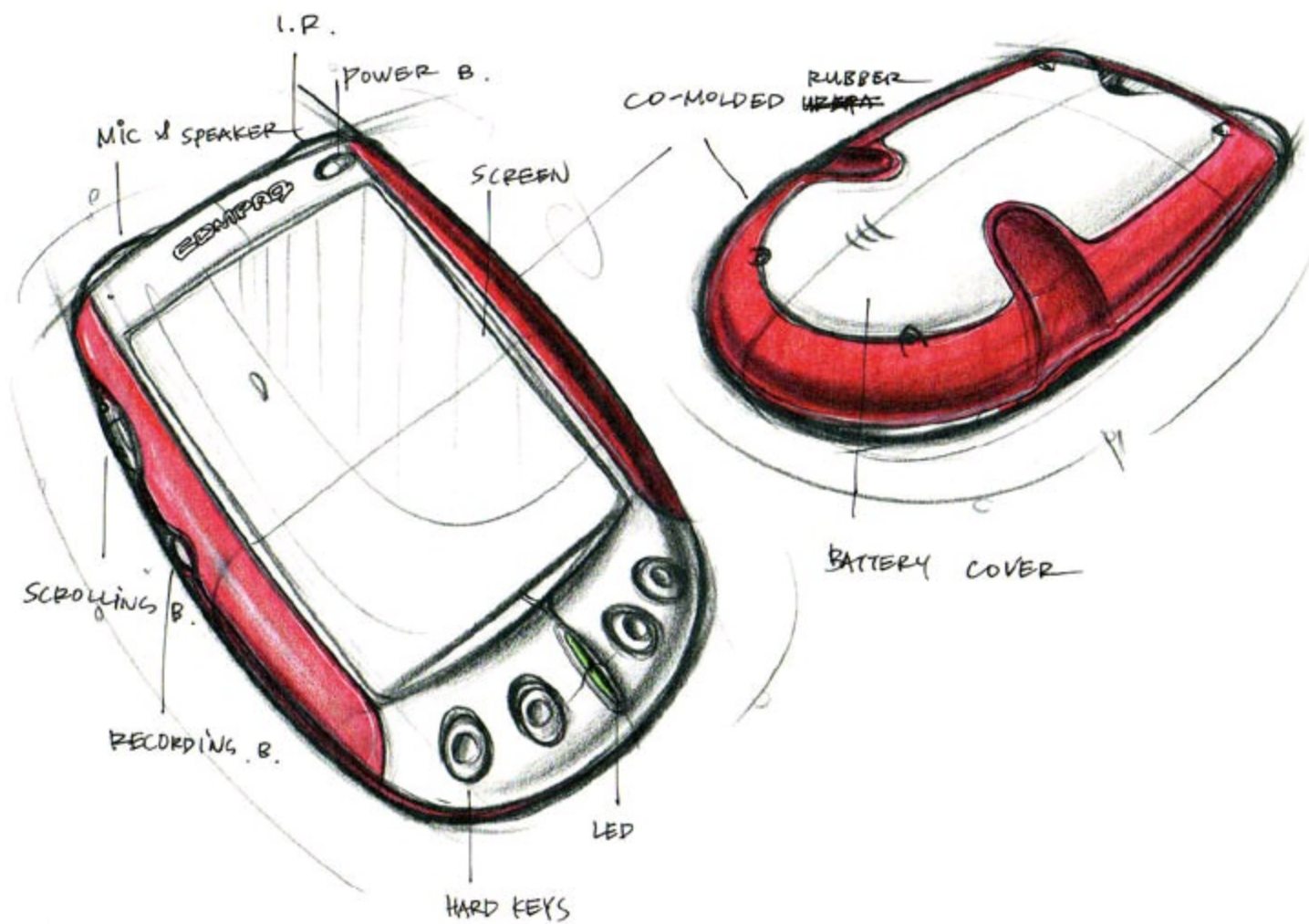

Concepts for internal review

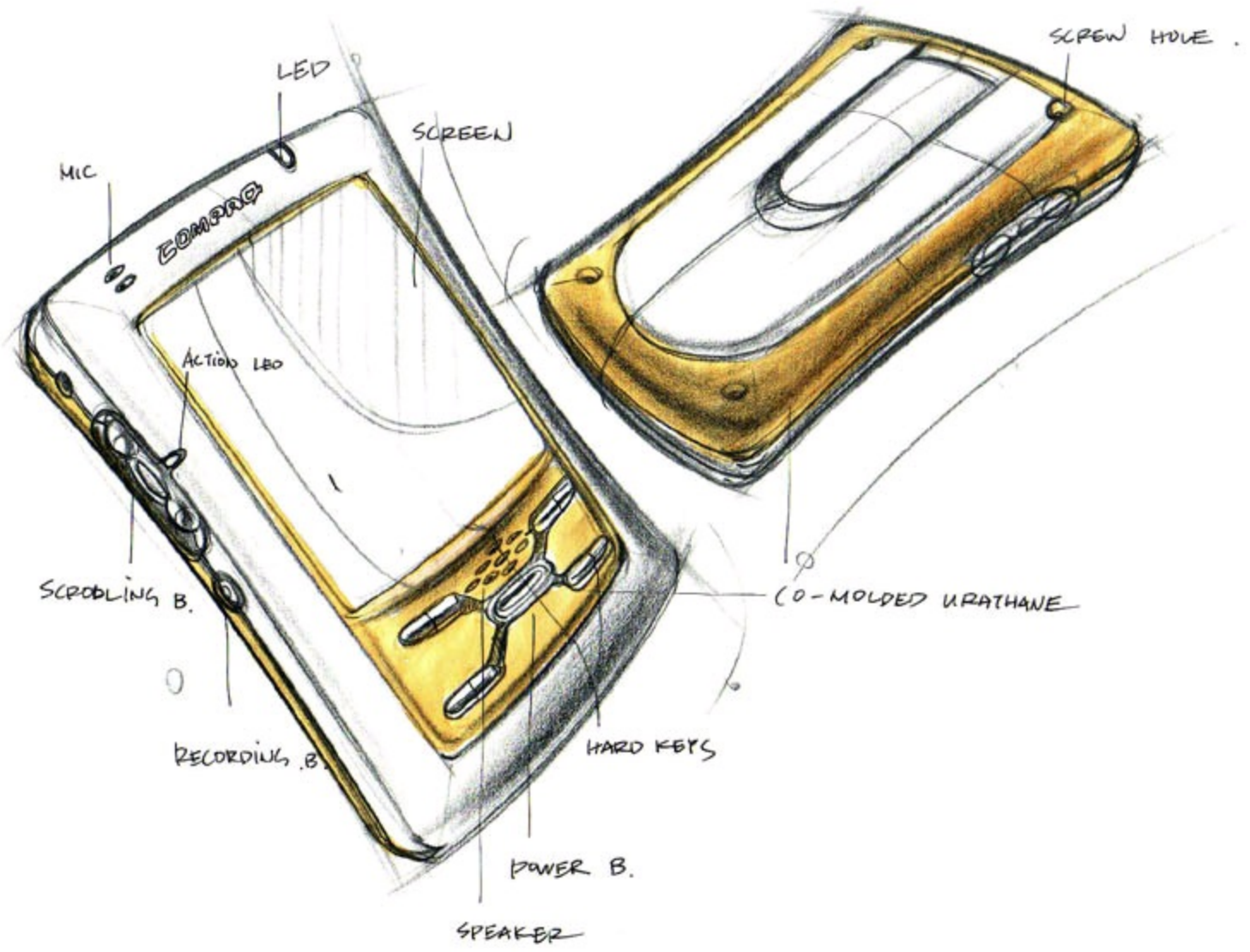

Concepts for internal review

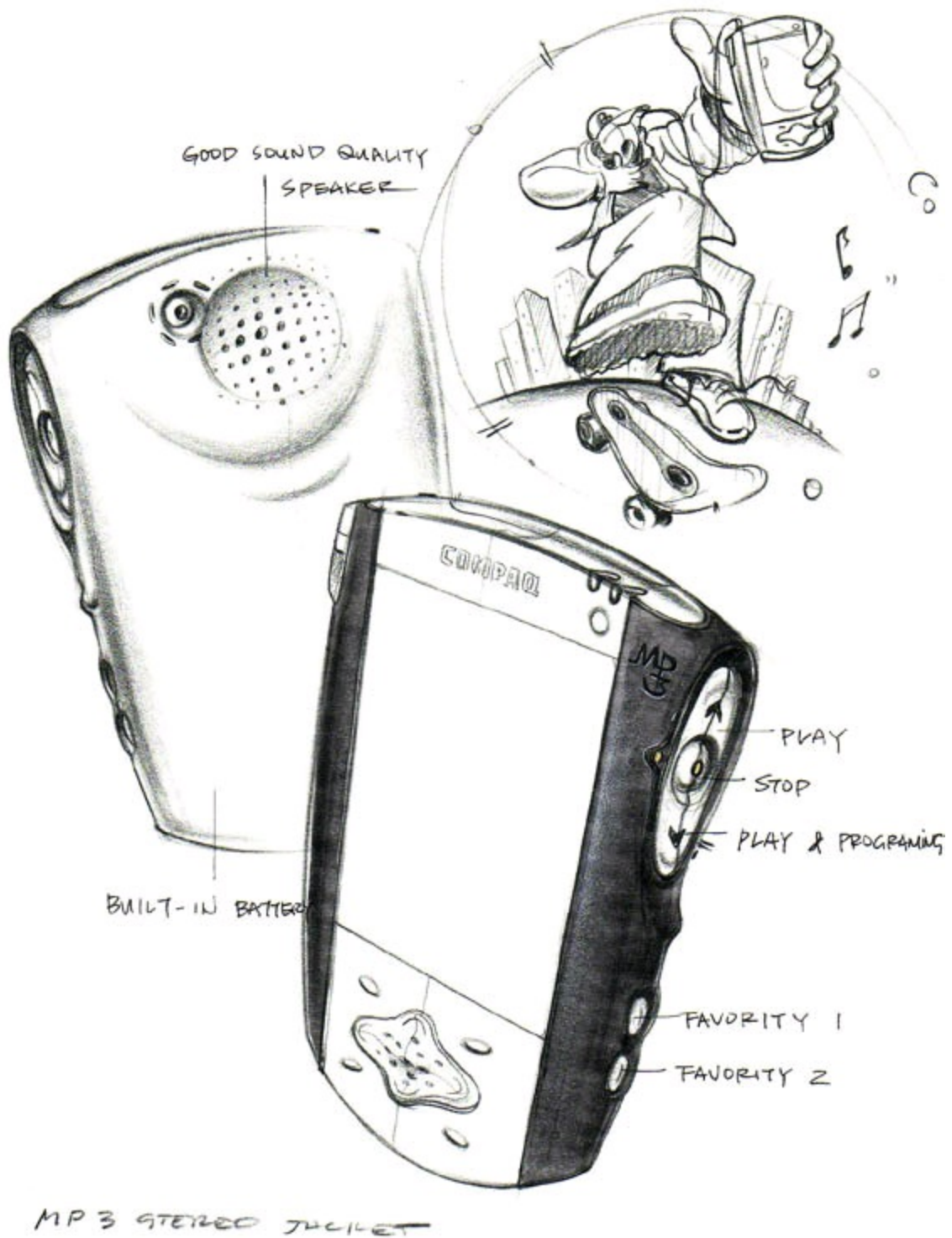

I did these scenarios to illustrate the possibilities of a mobile hand held devise could do in our daily life. Through different feature jacket, the iPaq could transform into a specific tool for specific user group. These scenarios also helped the Compaq business team to visualize the trends of the PDAs, so the team could plan for the future. MP3 music jacket with a built-in load speaker

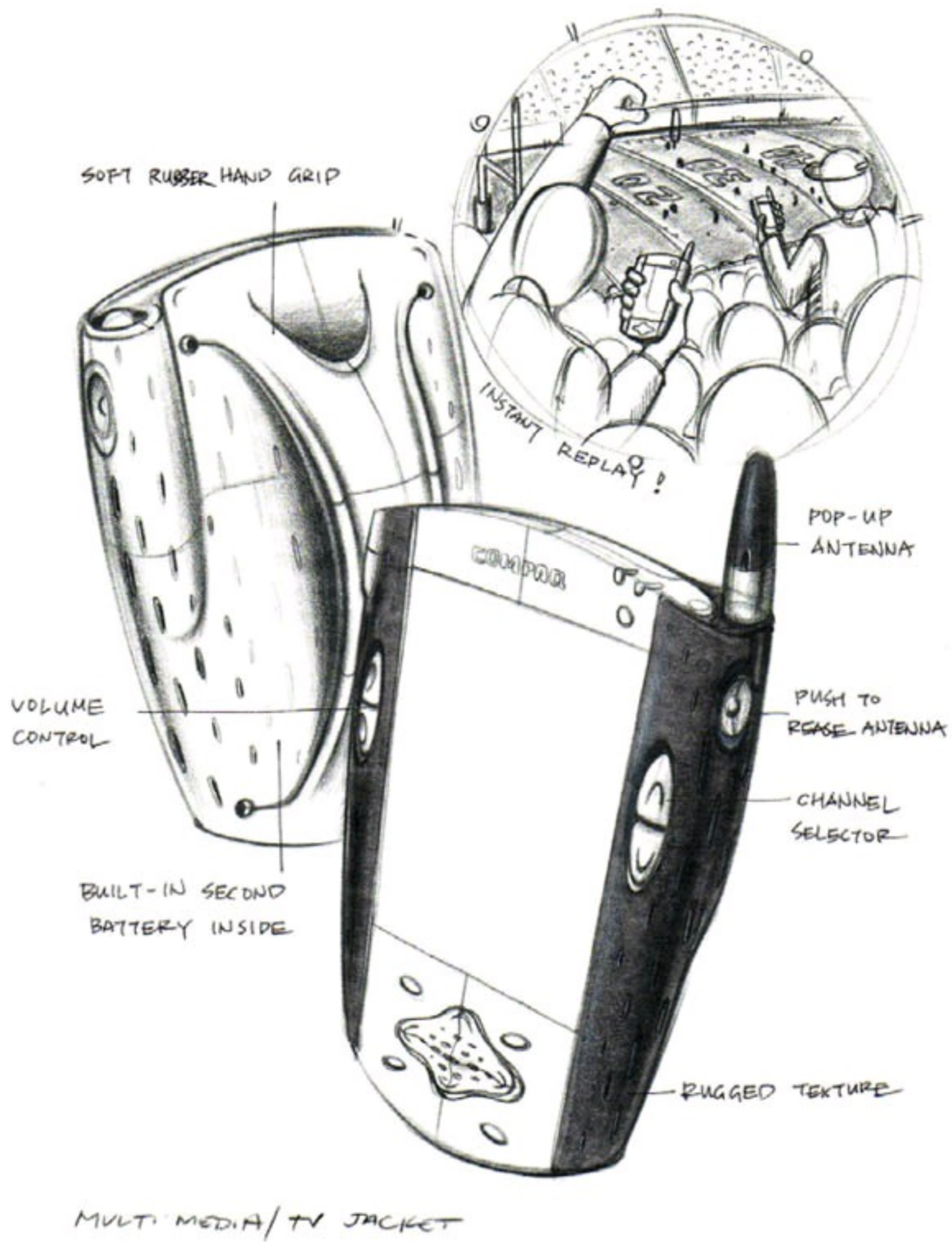

Protection jacket with an over sized hand grip

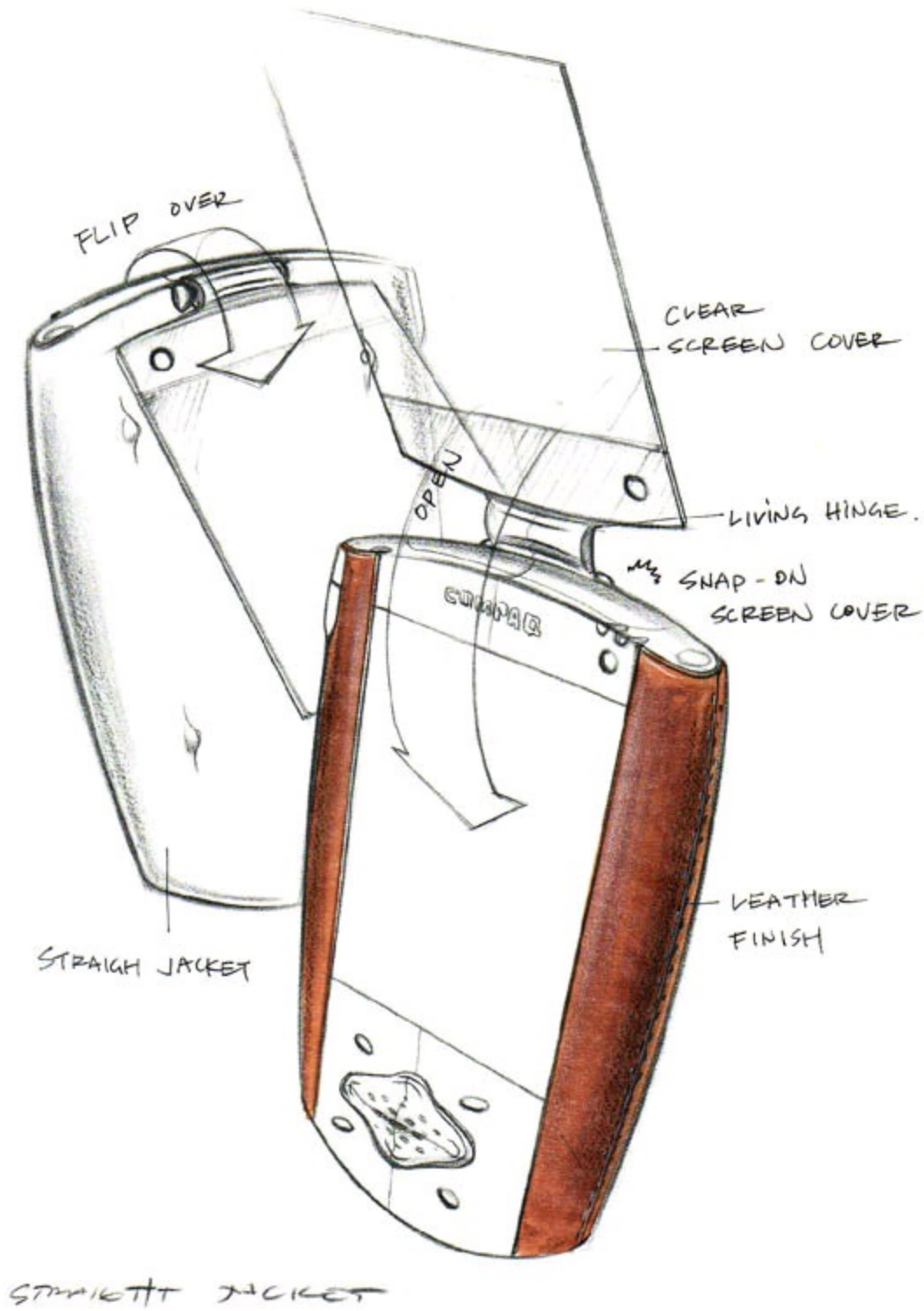

Acrylic screen protection on basic jacket

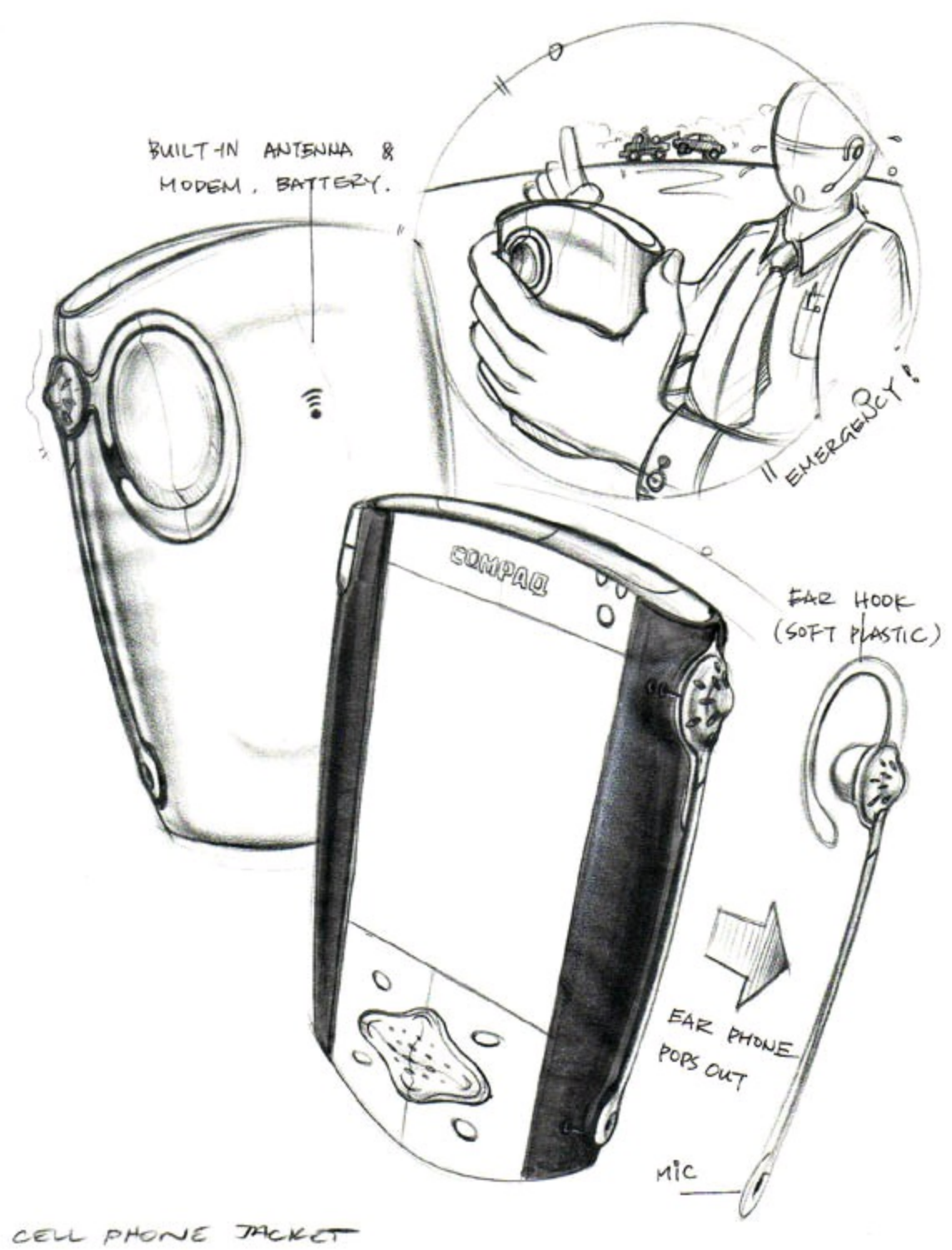

CELL PHONE JACKET

Blue tooth head set. Antenna is inside the jacket

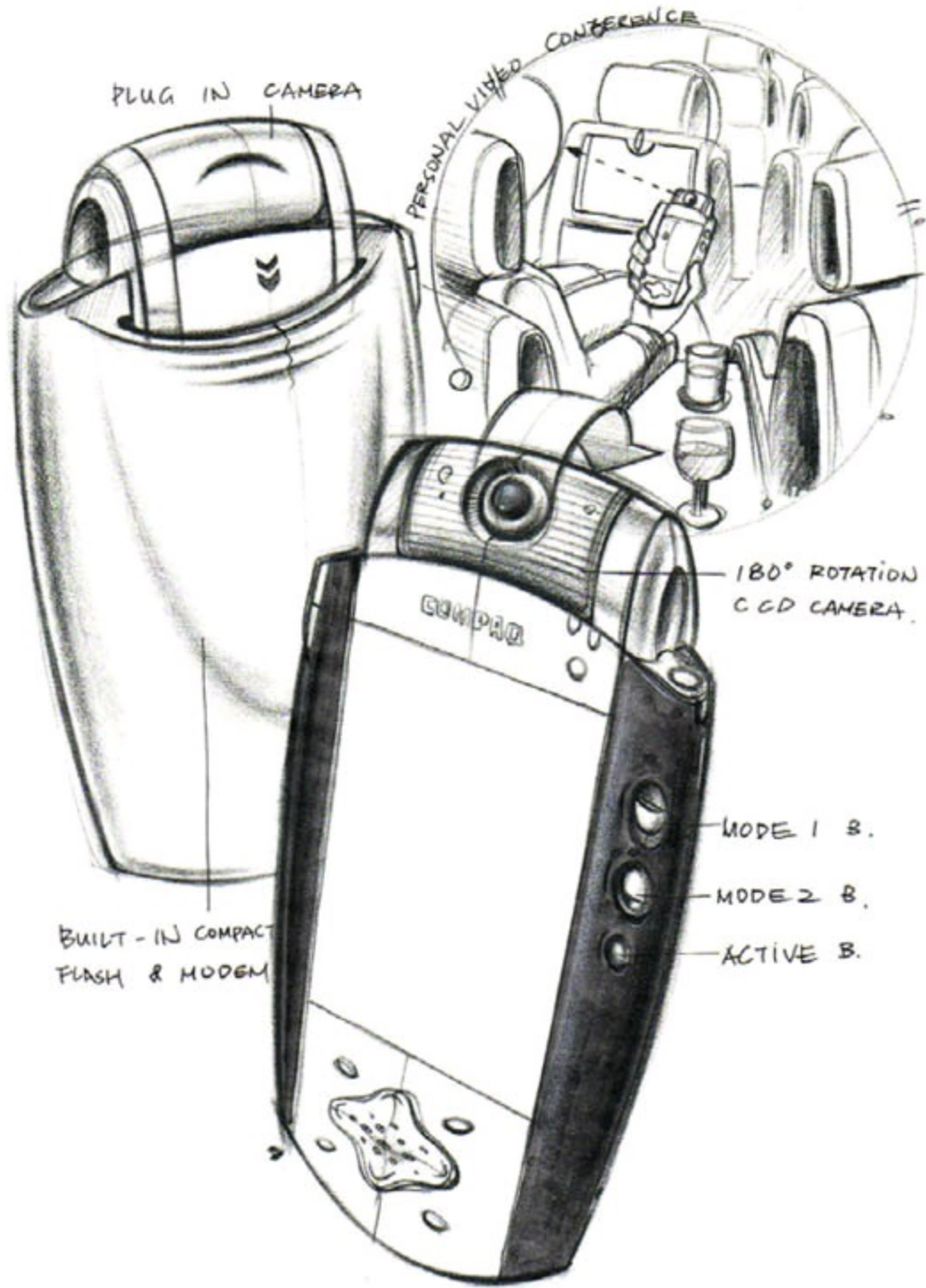

DIGITAL VIDEO/STILL TRACKET

Swivel camera lens with a built-in printer



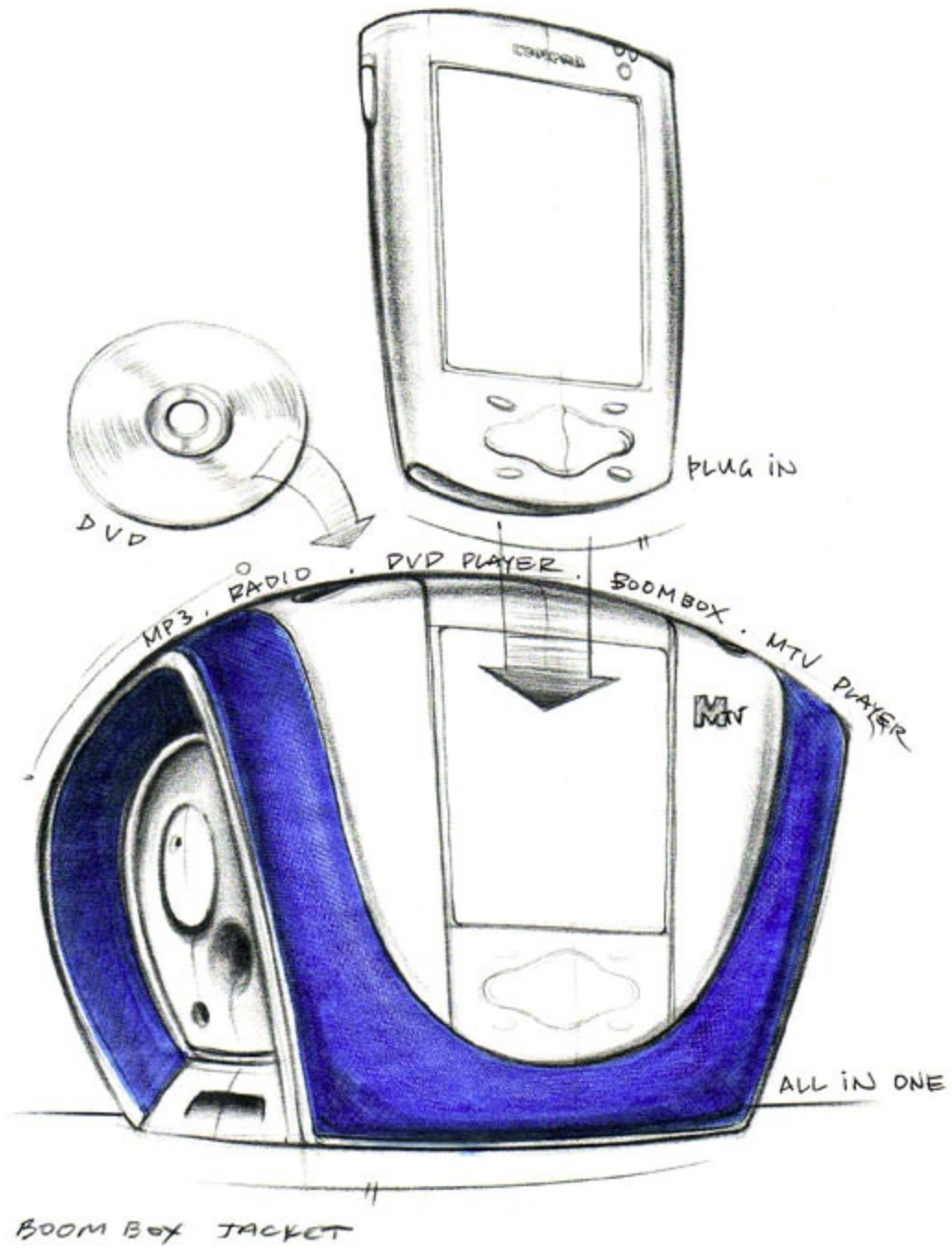

Stereo boom box with an iPaq as a music player

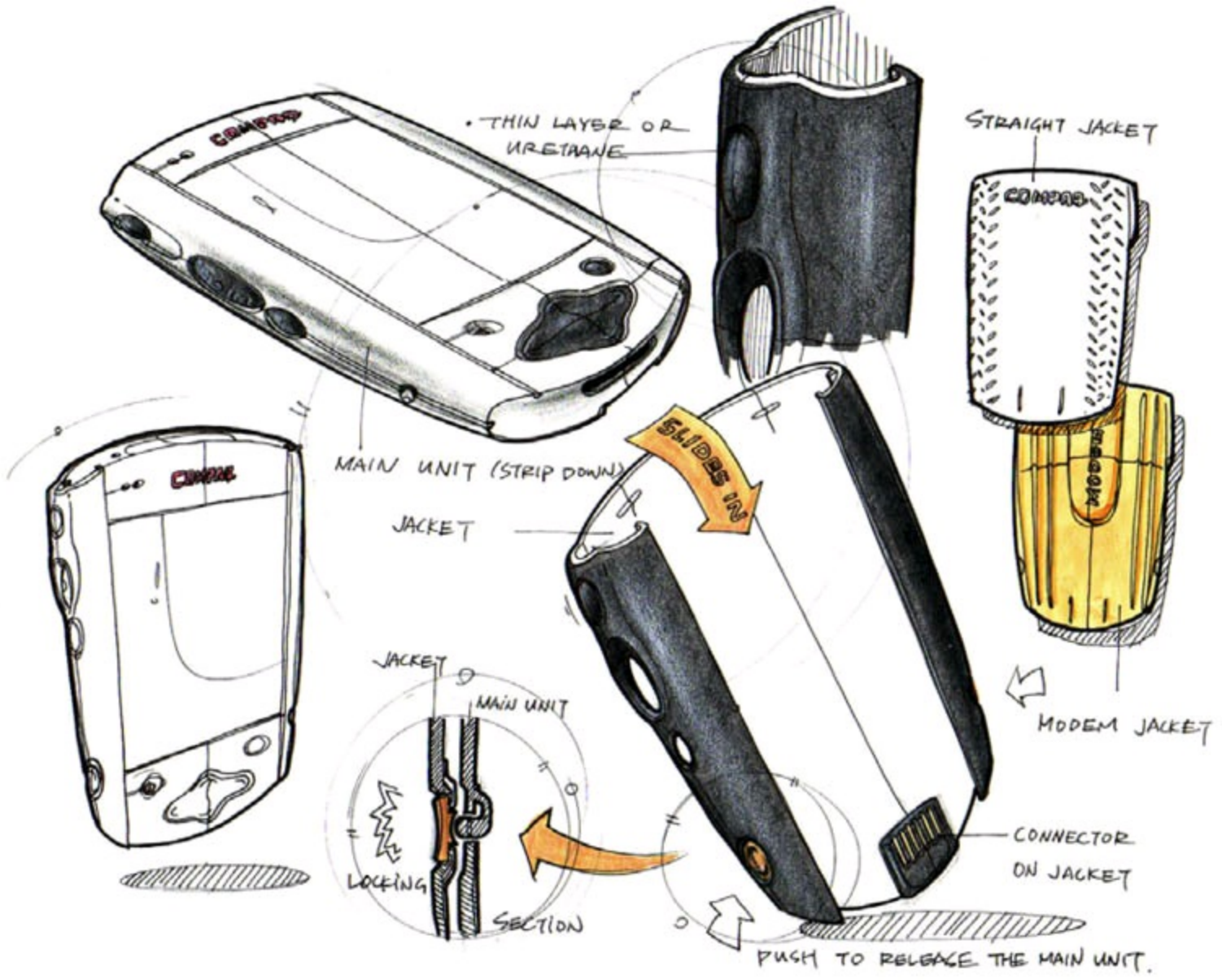

This is how to connect the PDA and the Feature Jacket.

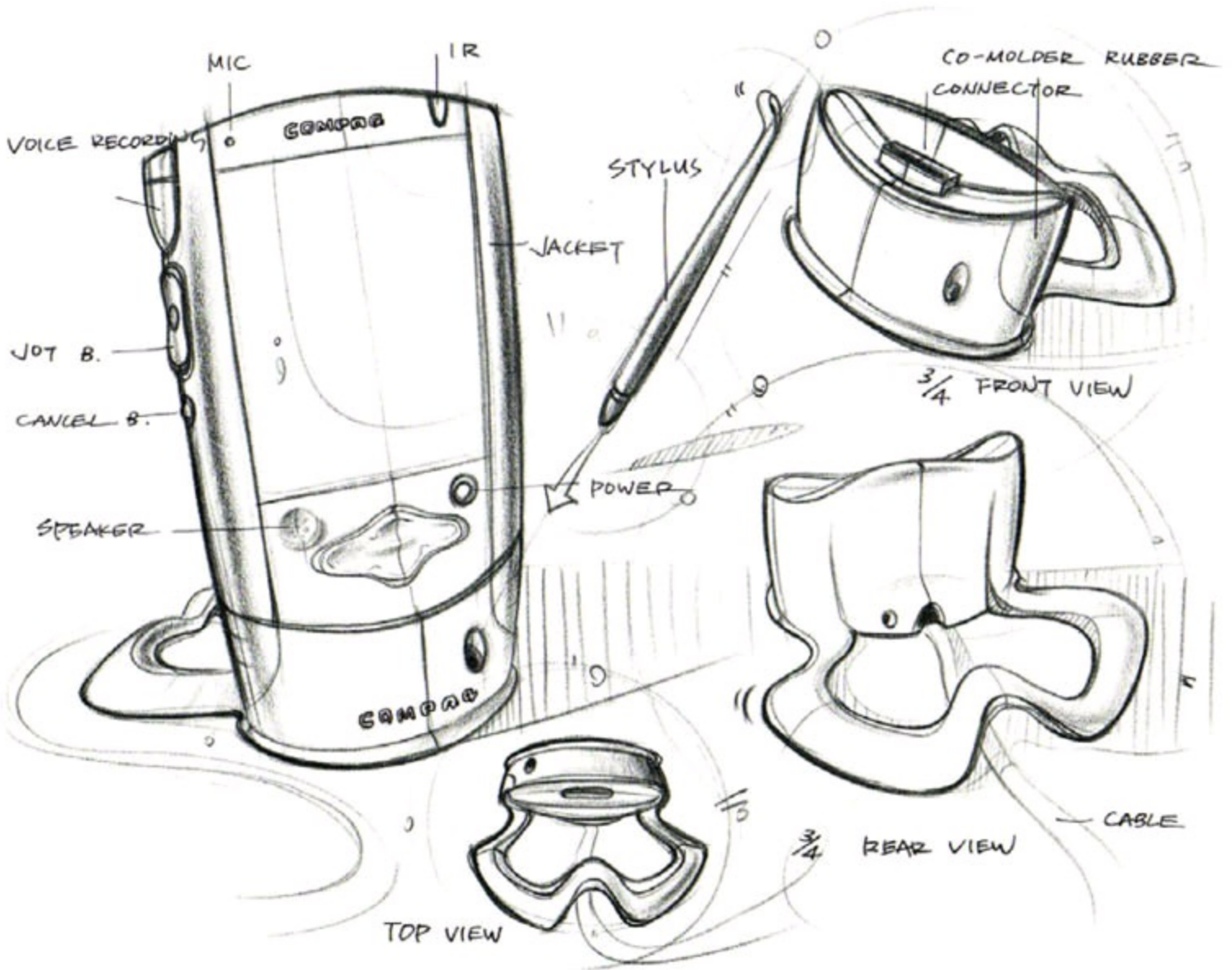

Tried to visualize how the complete unit goes together.

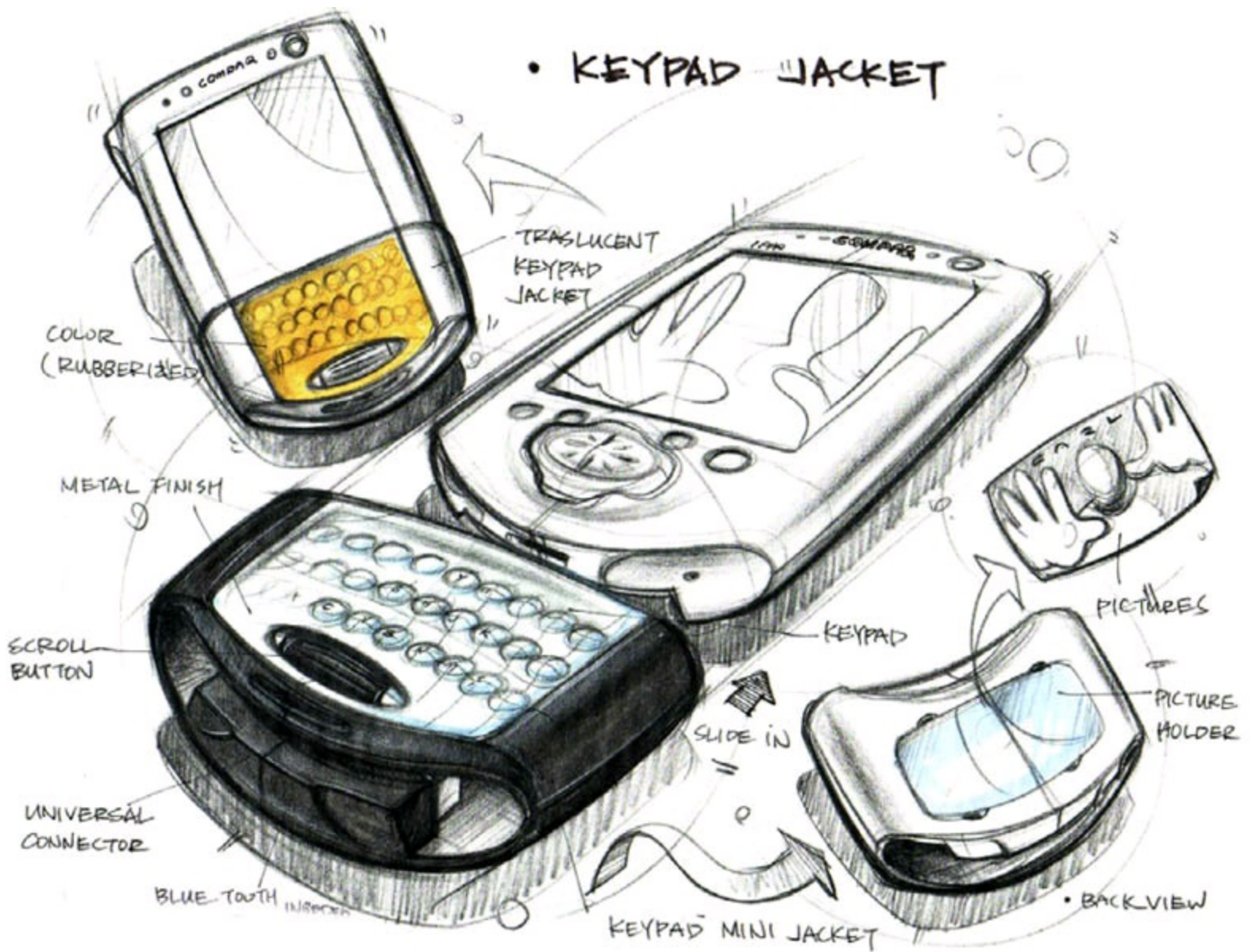

Half jacket for QWERTY keypad. The idea did not get picked by Compaq, but later, it was found in other PDA type products.

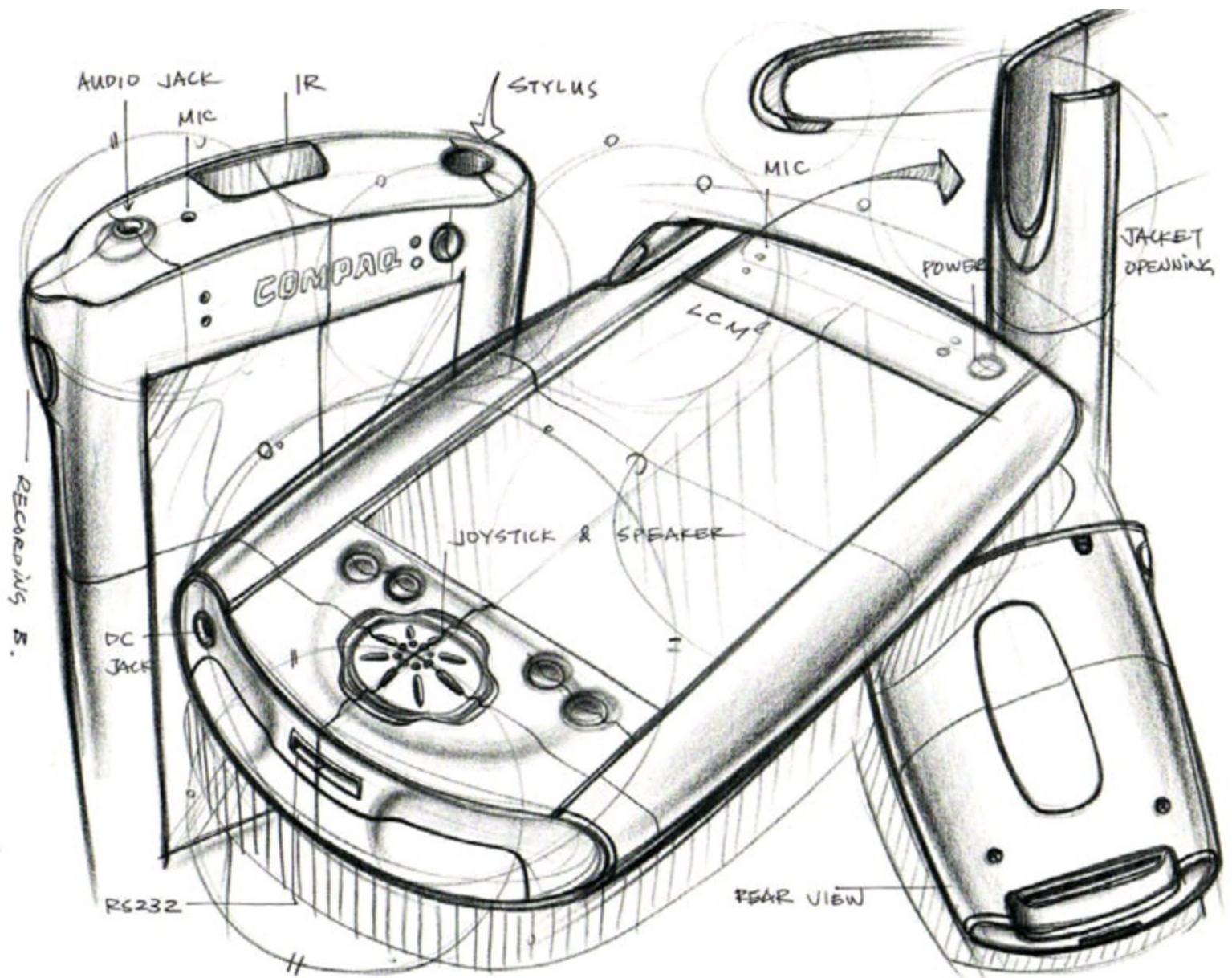

Stylus holder with a push-push mechanism inside. Cut-out for pin connectors.

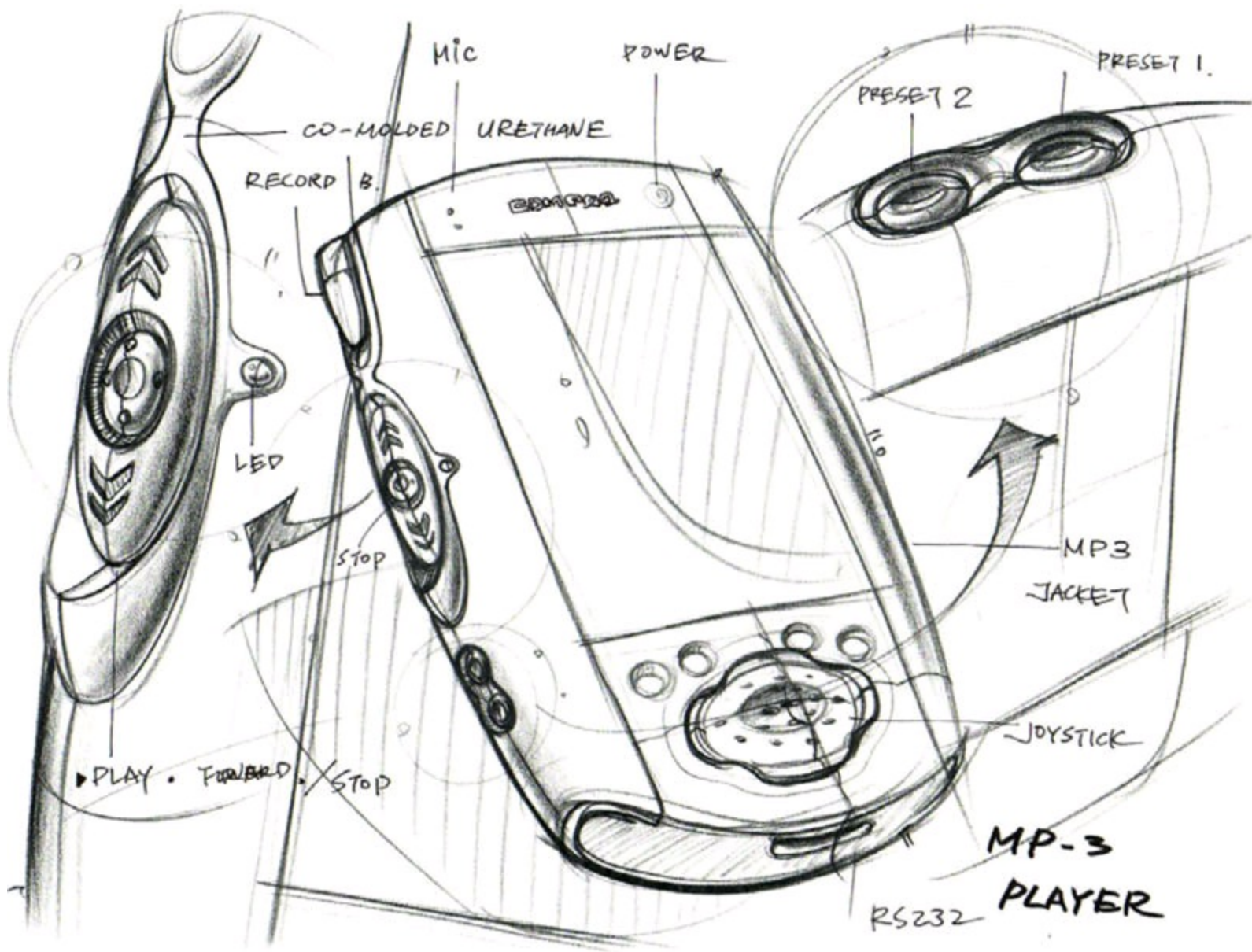

Detail sketch of music control keys on a MP3 jacket.

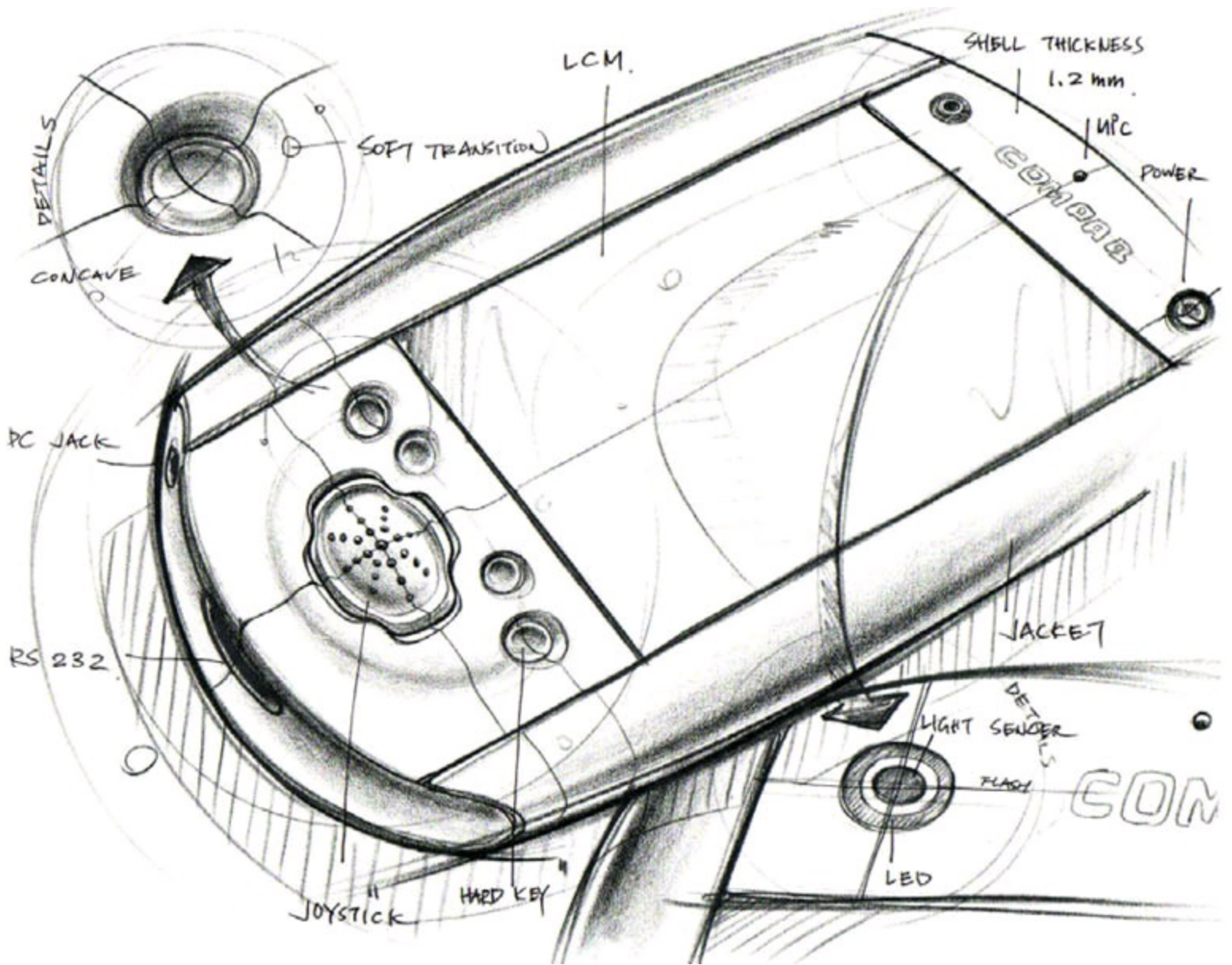

Design of display light sensor and signal indication light. Detail sketch of hard keys and surrounding surface.

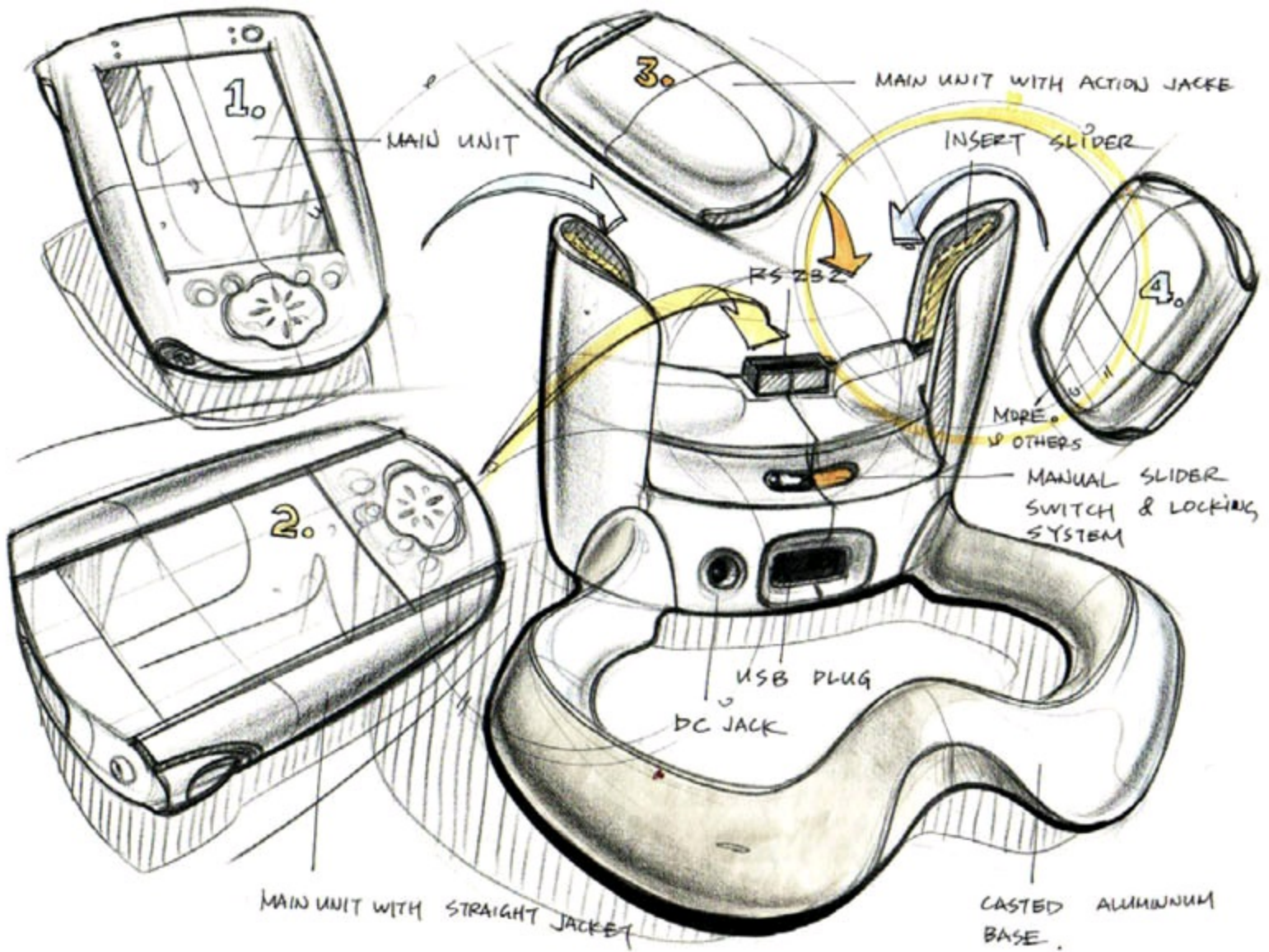

The innovative cradle design can fit multiple-size feature jackets. The yellow part is the insert slider.



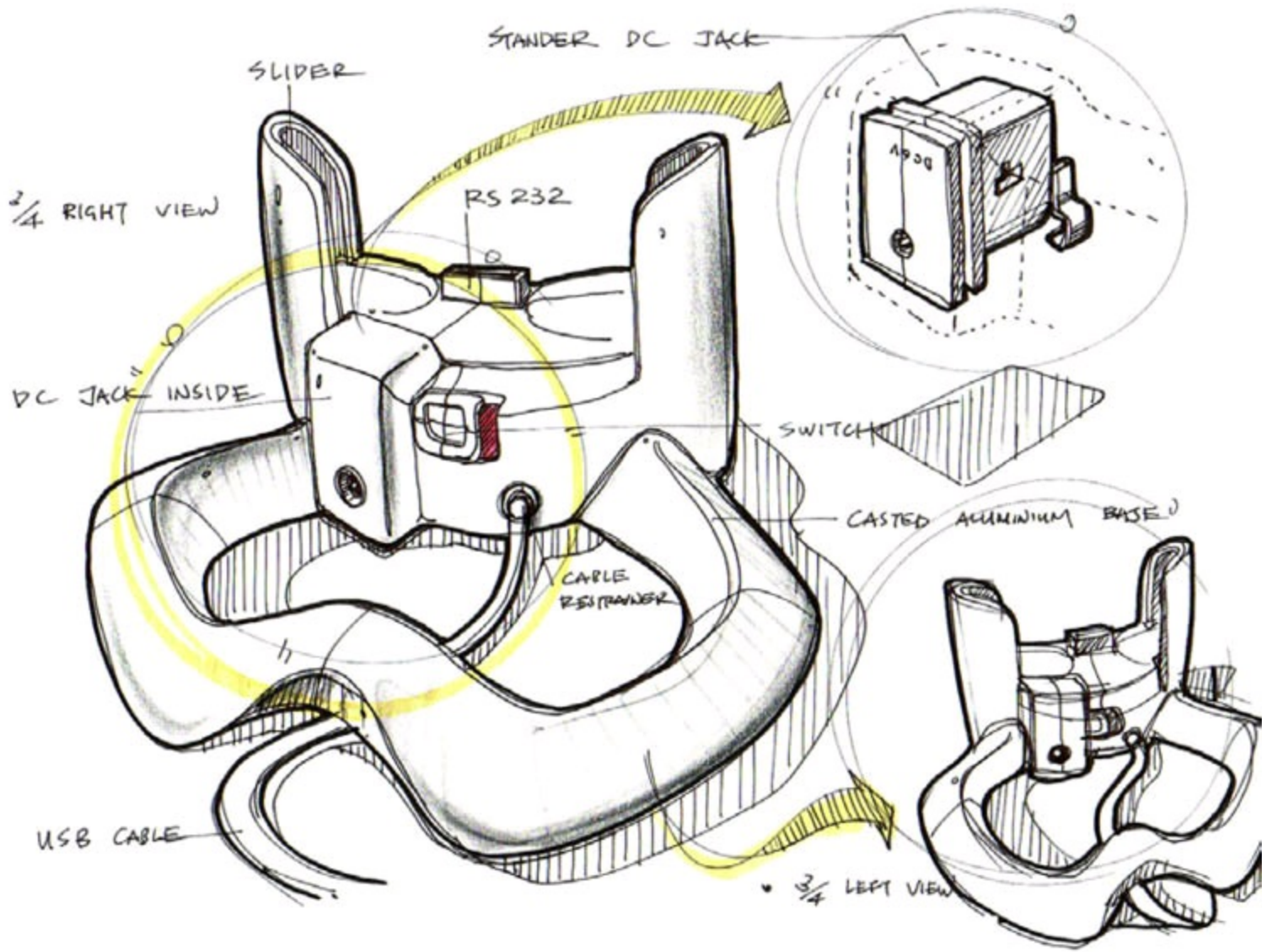

The engineering team wanted the DC jack to be integrated into the cradle at first. I illustrated how much it would affect the final design if they insisted to do so.

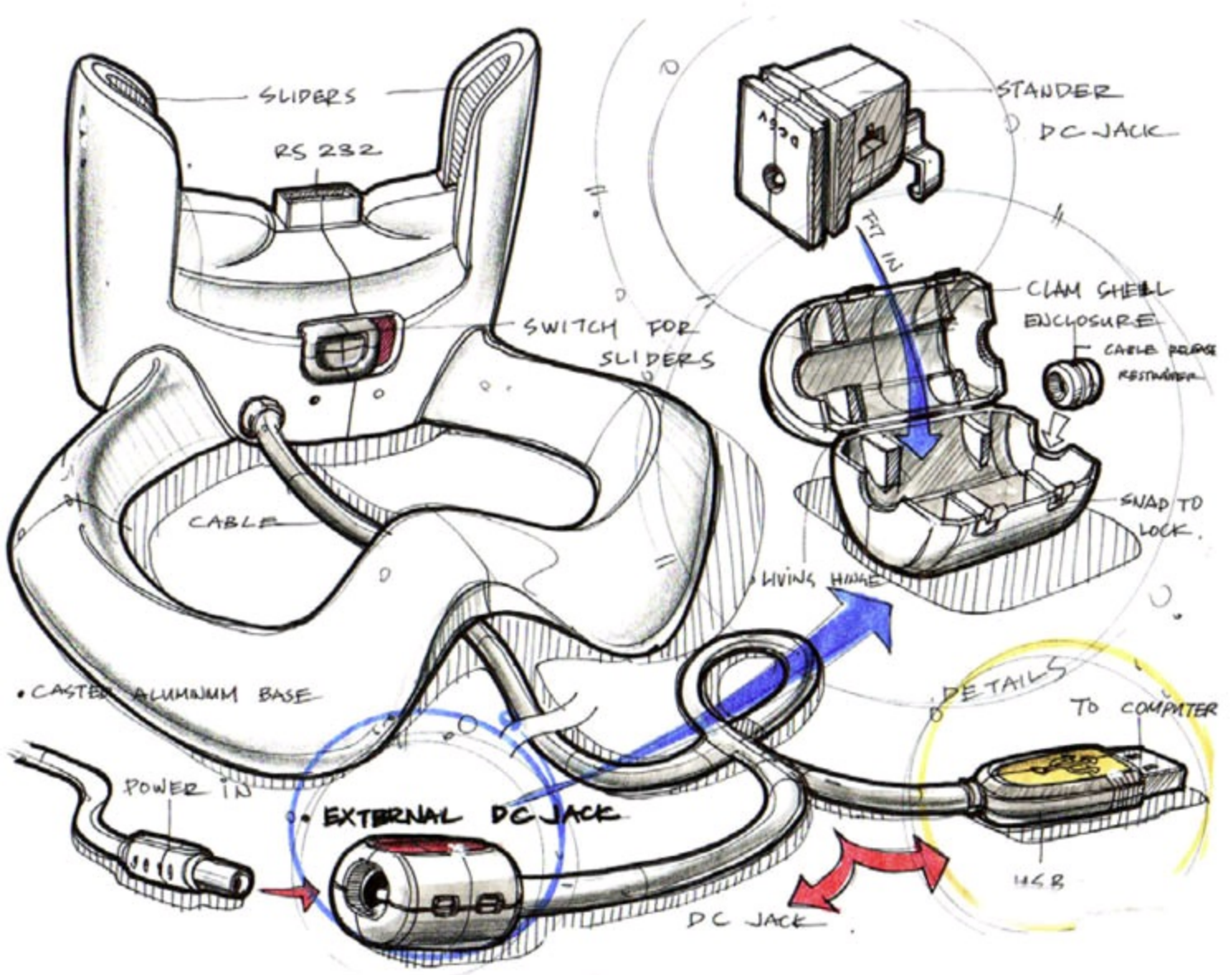

I gave the engineers a solution for separating the big DC jack from the cradle. They finally accepted the idea.

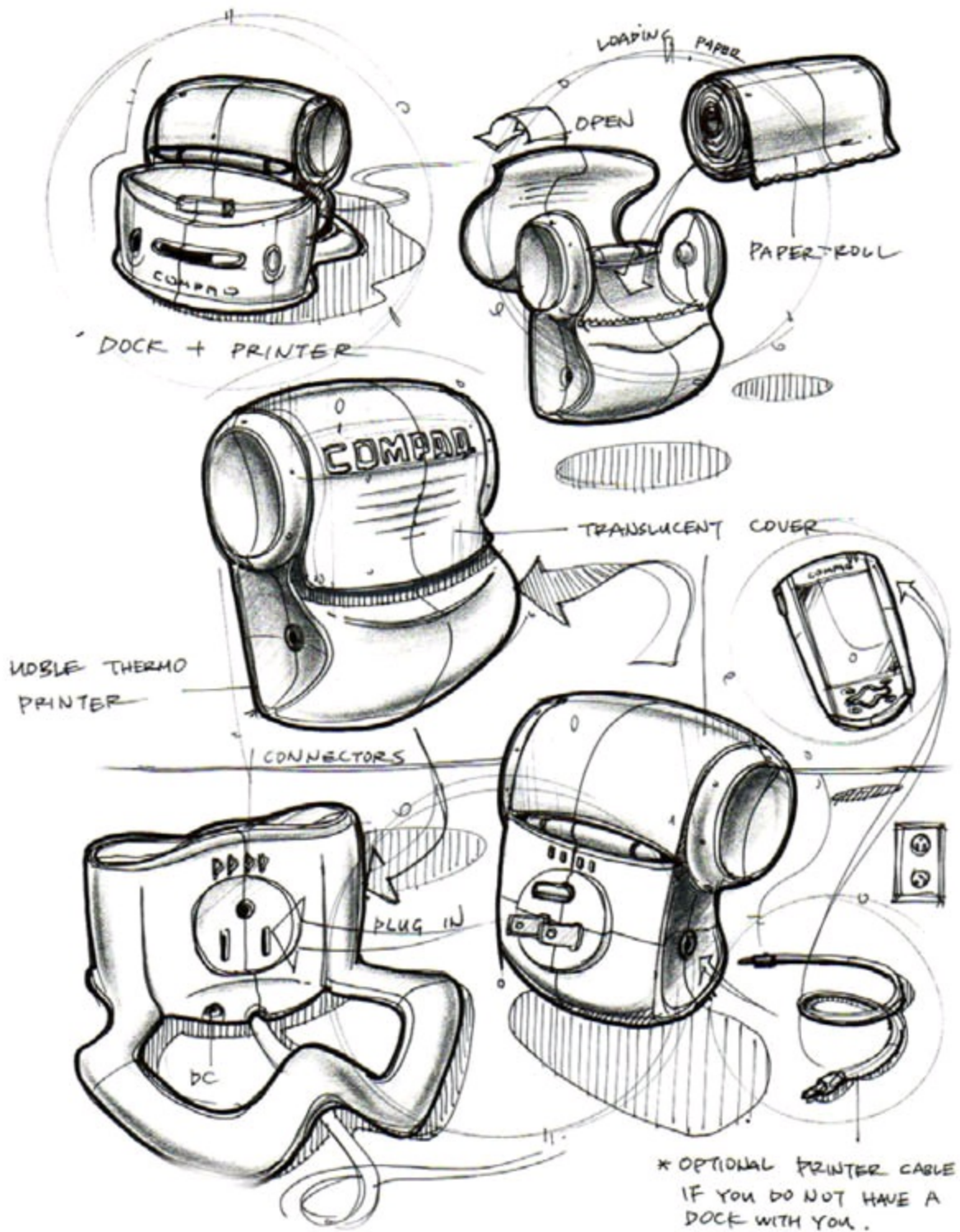

Optional thermo printer unit for printing small memos. This page shows some ideas did not get picked up by the core team, but I still think some of the ideas are valuable.

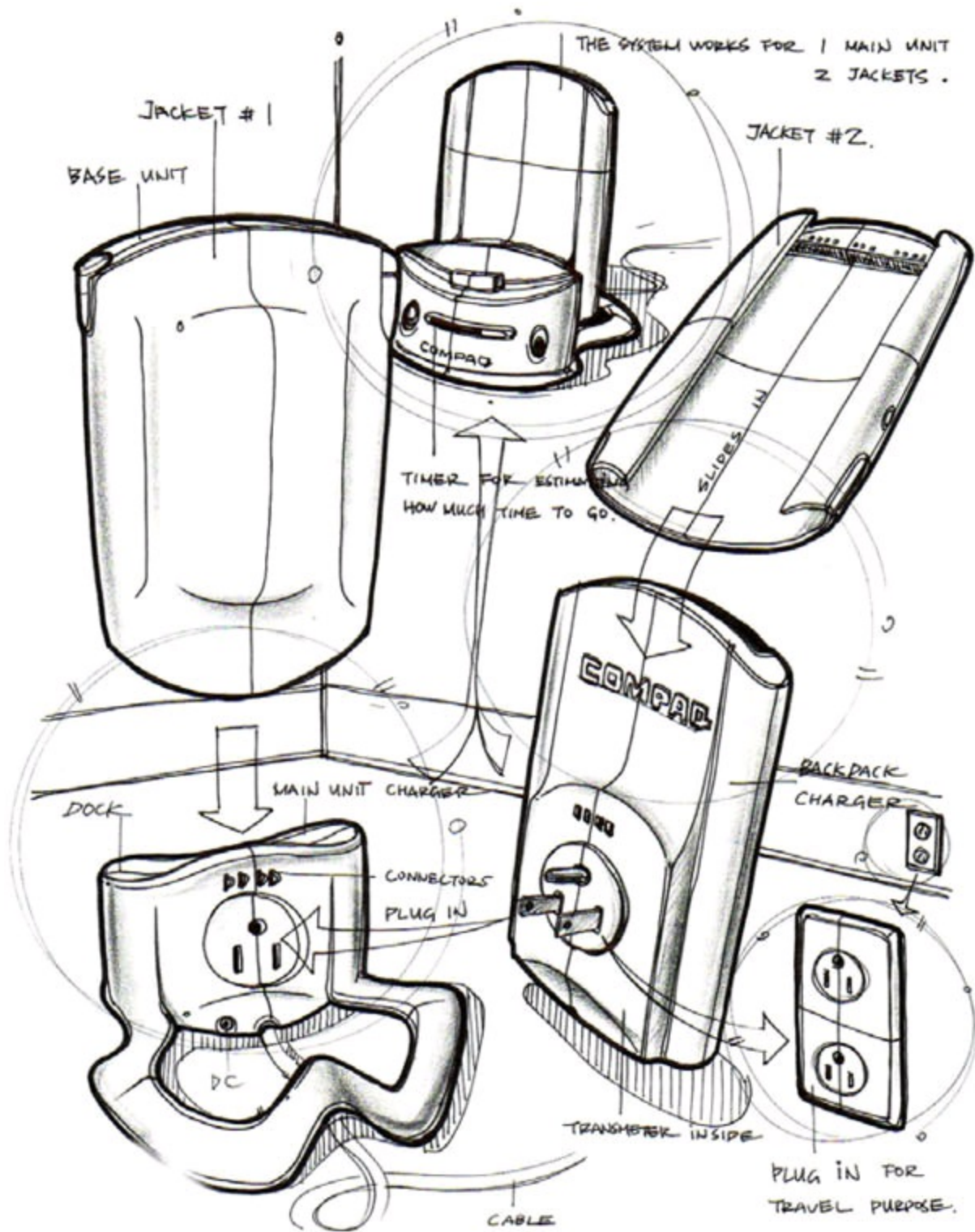

Some of the feature jackets might have in-bed batteries, so I designed the optional jacket charger for extra jackets.

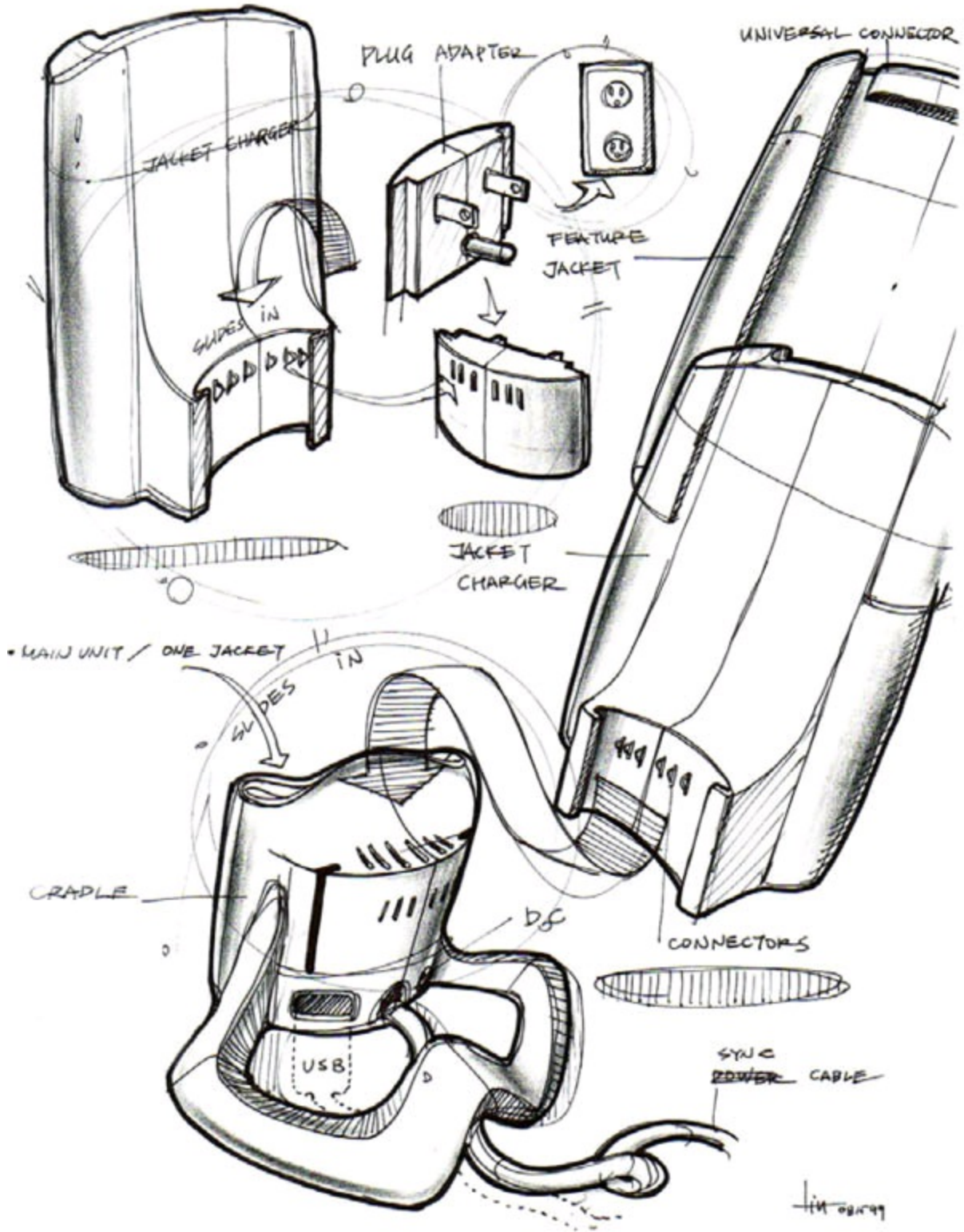

A different way of connecting the cradle and the jacket charger by using gold finger. Plug it into the cradle type connector instead of using socket connector.

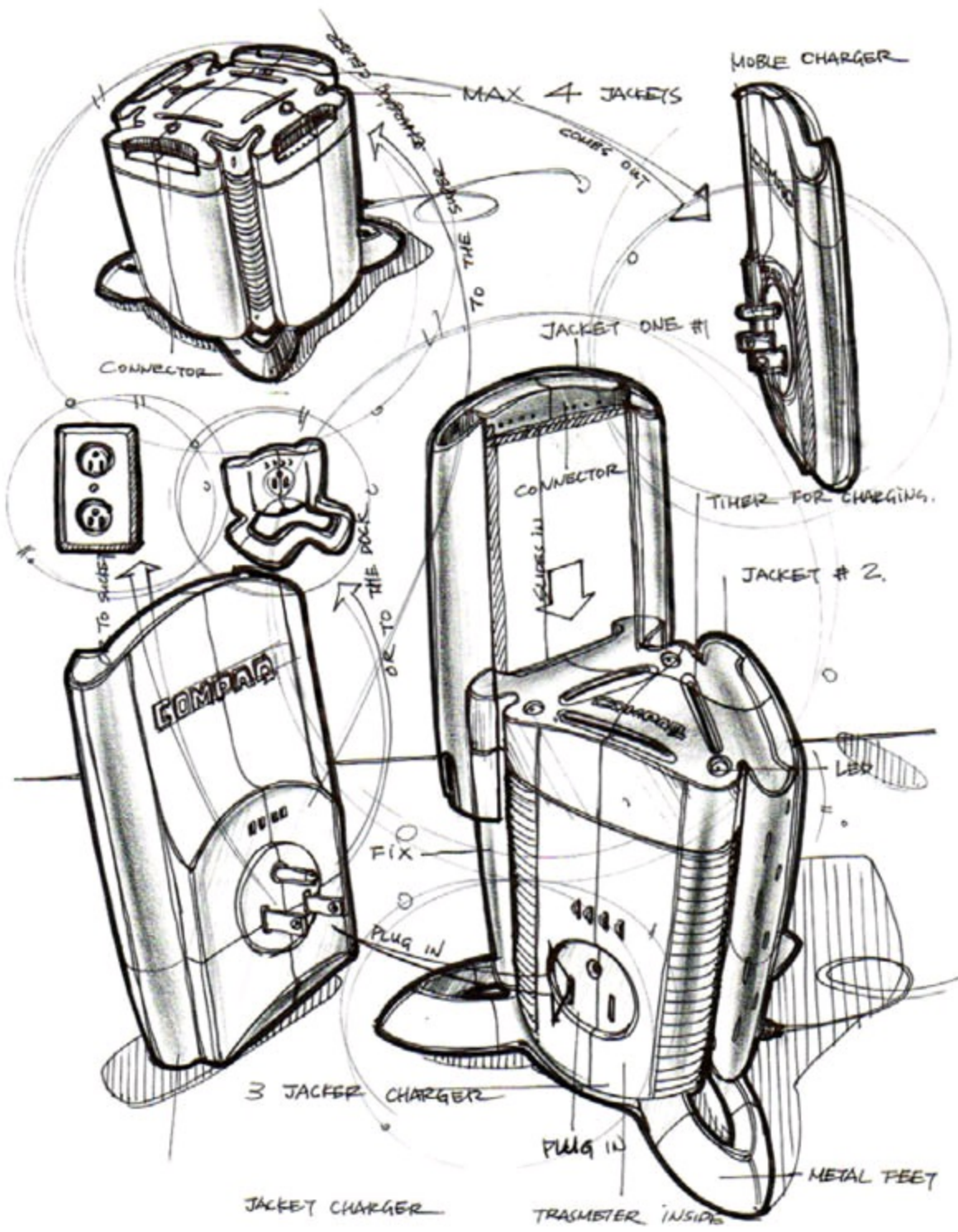

Continuing the last page, I created the jacket charging system for more than one jacket.

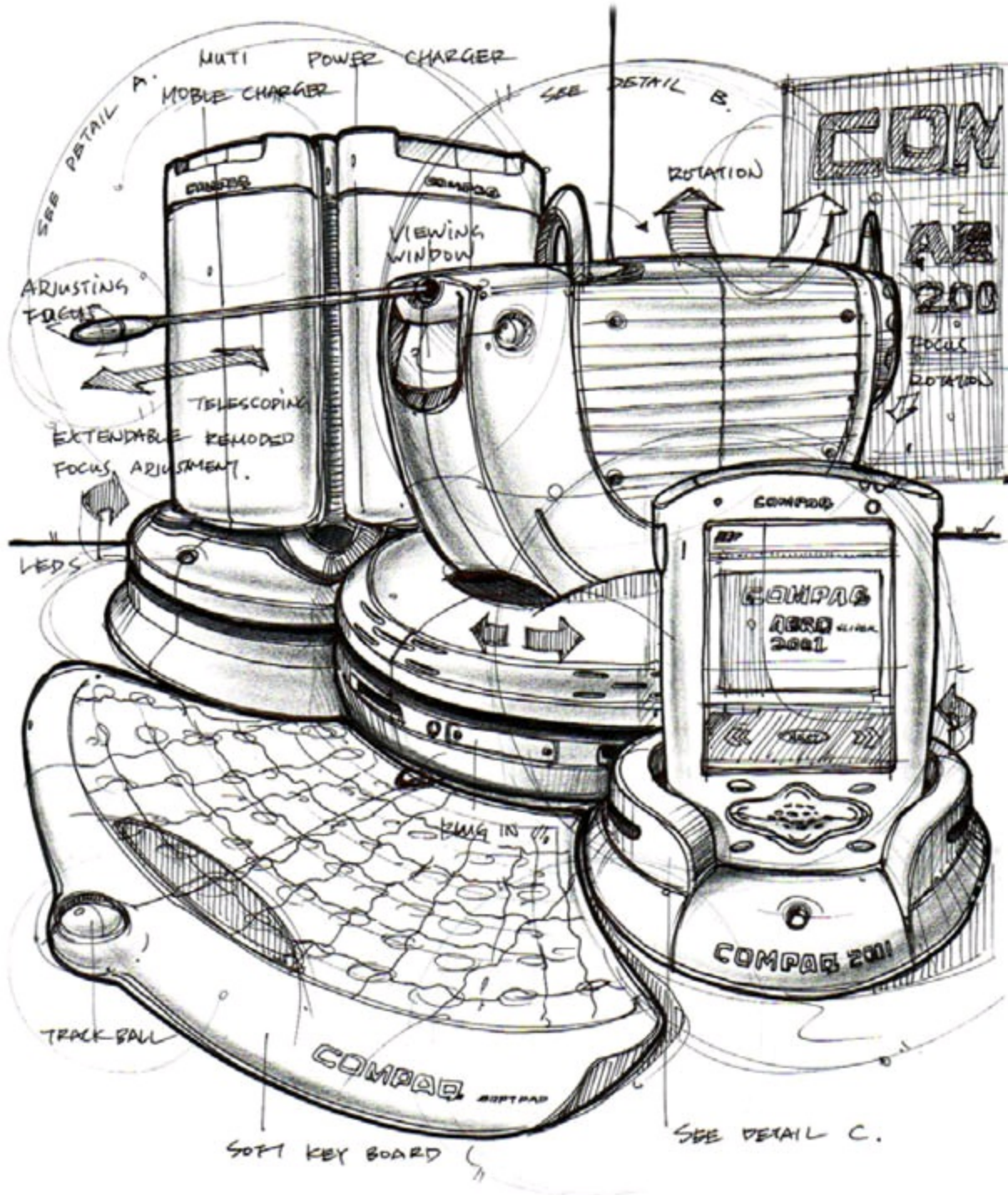

iPaq working system, it included a projector, a center link unit, a flexible keyboard and the iPaq.

# CASIO LCM VS. SHARP LCM

## A. (CASIO LCM)

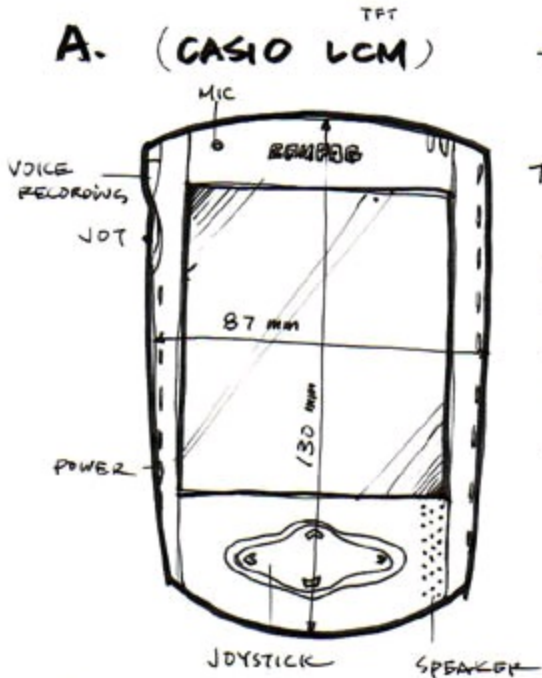

TRANSMISS.

THICKNESS: ~~14.5~~ 14.5 mm (W/JACKET)  
13 mm (N/JACKET)

- 2 PCB BOARD
- CUSTOM AUDIO JACK
- RAM IS NOT UPGRADEABLE.
- BATTERY VOLUME =  $14.5 \times 10^3 \text{ mm}^3$
- SMALL STYLUS. (80 mm)

## B. (SHARP LCM)

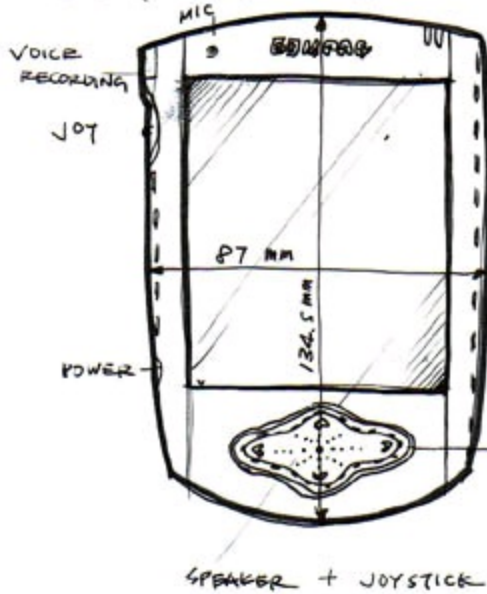

BACKLET

THICKNESS: 15 mm (W/JACKET)  
13.5 mm (N/JACKET)

- 3 PCB BOARD
- CUSTOM AUDIO JACK.
- SIDE BUTTON IS NOT INCLINED WITH THE SWITCH.
- RAM IS NOT UPGRADEABLE.
- HAS BETTER POTENTIAL TO MAKE IT NARROWER BY REMOVING THE STYLUS TO THE BACK SIDE.
- BATTERY VOLUME =  $12.4 \times 10^3 \text{ mm}^3$

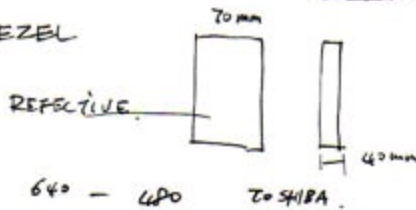

VGA

SONY ? → contract, whiteness.



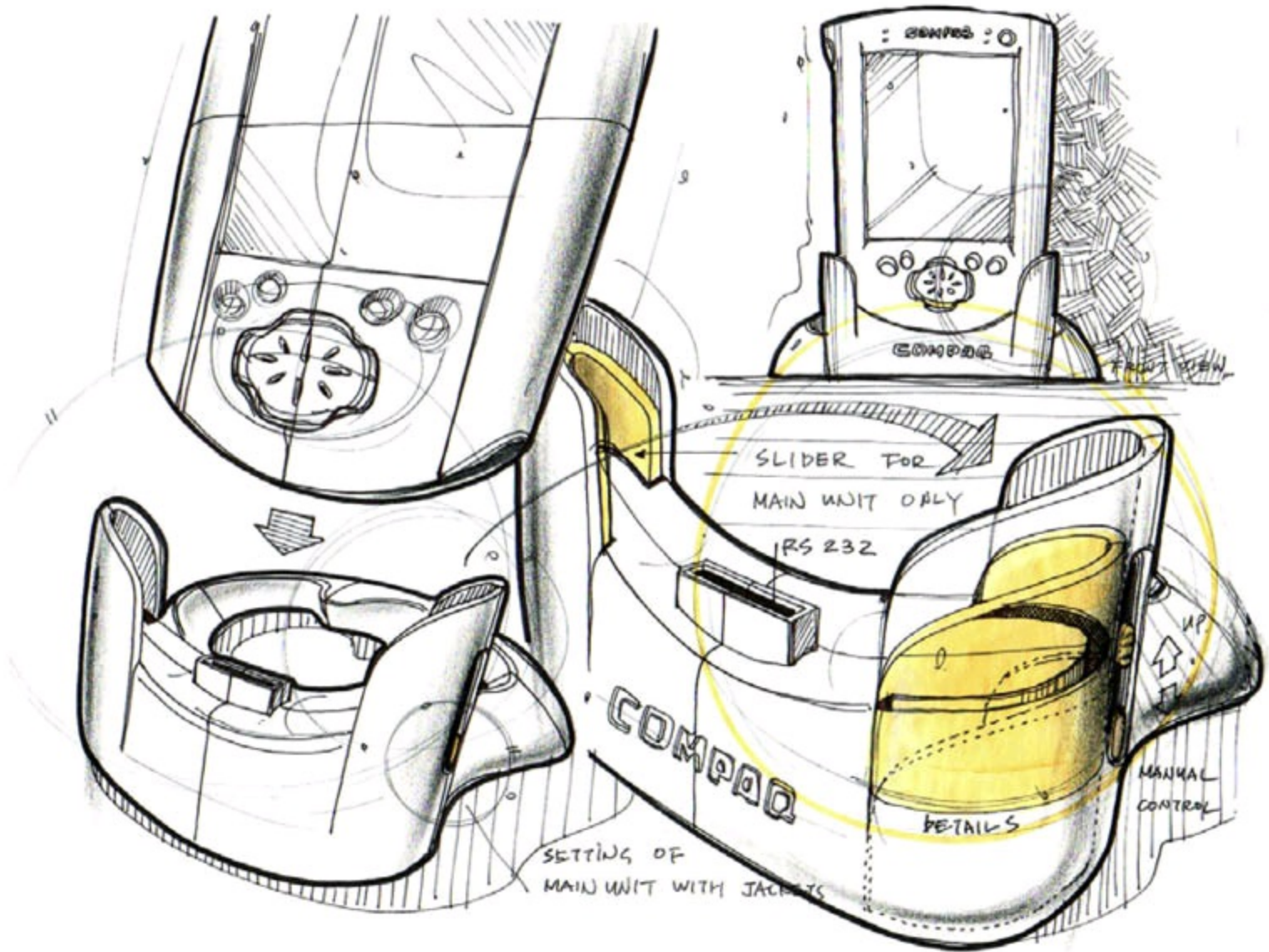

The insert slider would be pushed down when the iPaq + jacket was placed on the cradle.

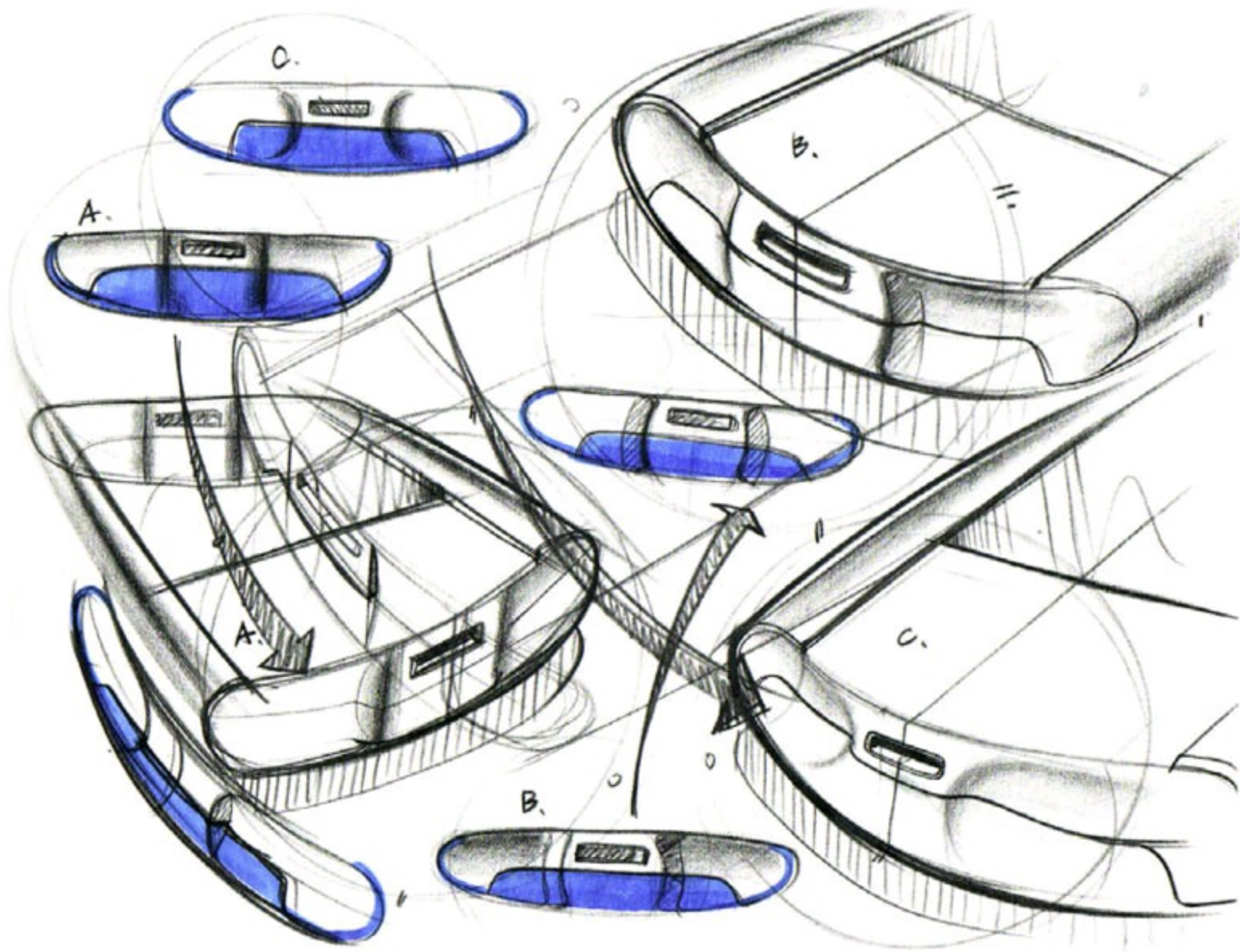

Design details around the connector, few options were exploring on this sketch.

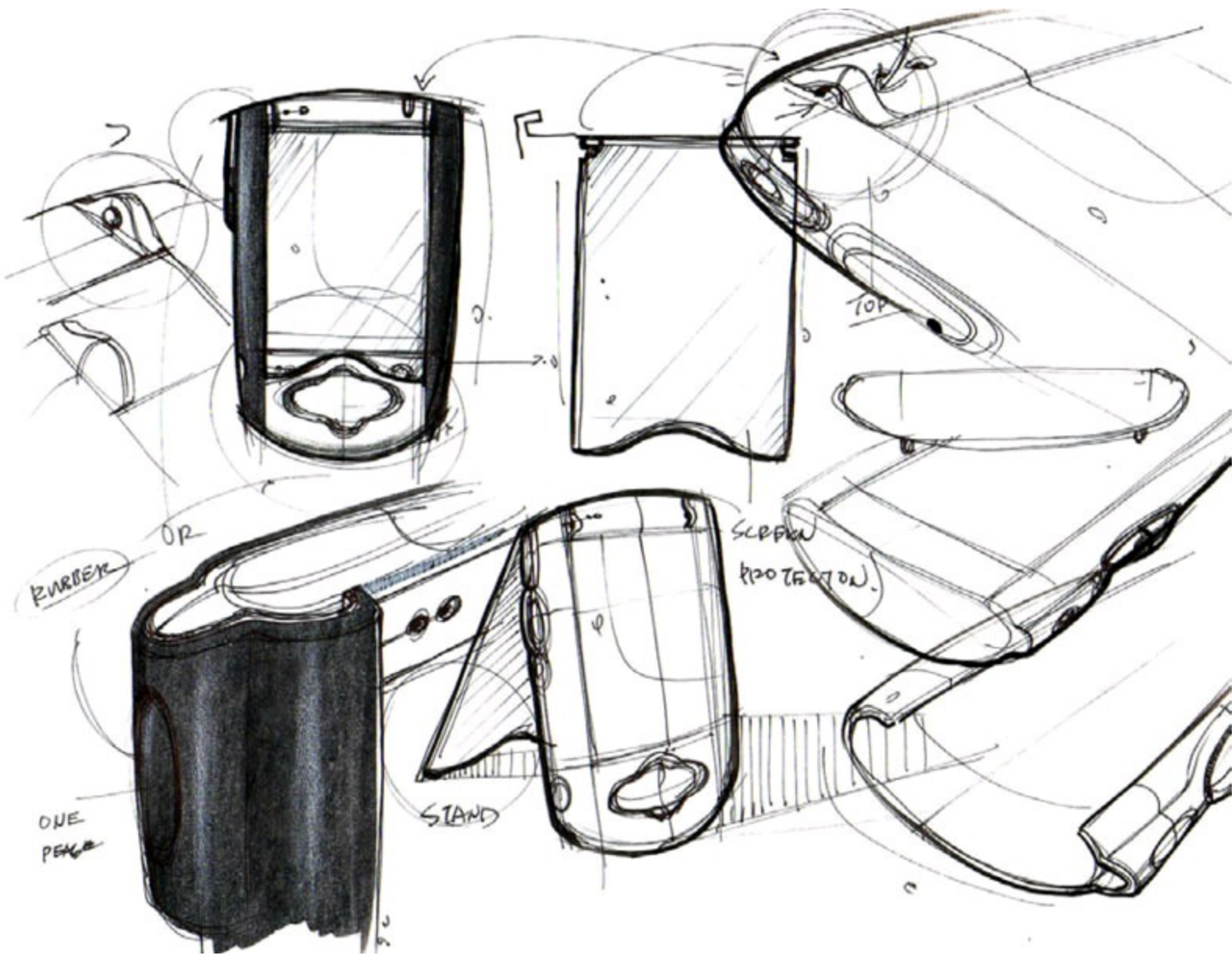

Detail sketch for the screen protection, I tried to find out the most simple and obvious solution.

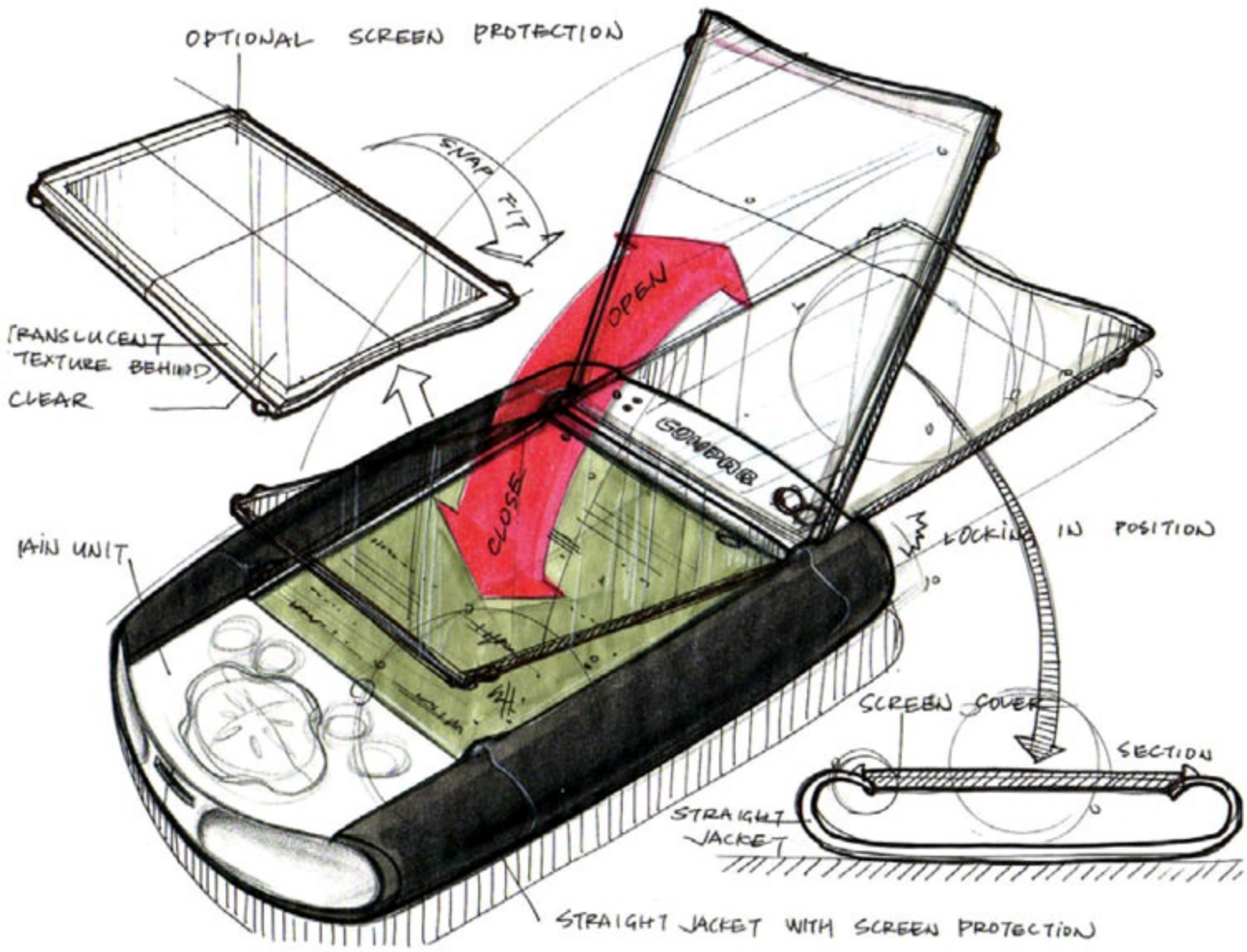

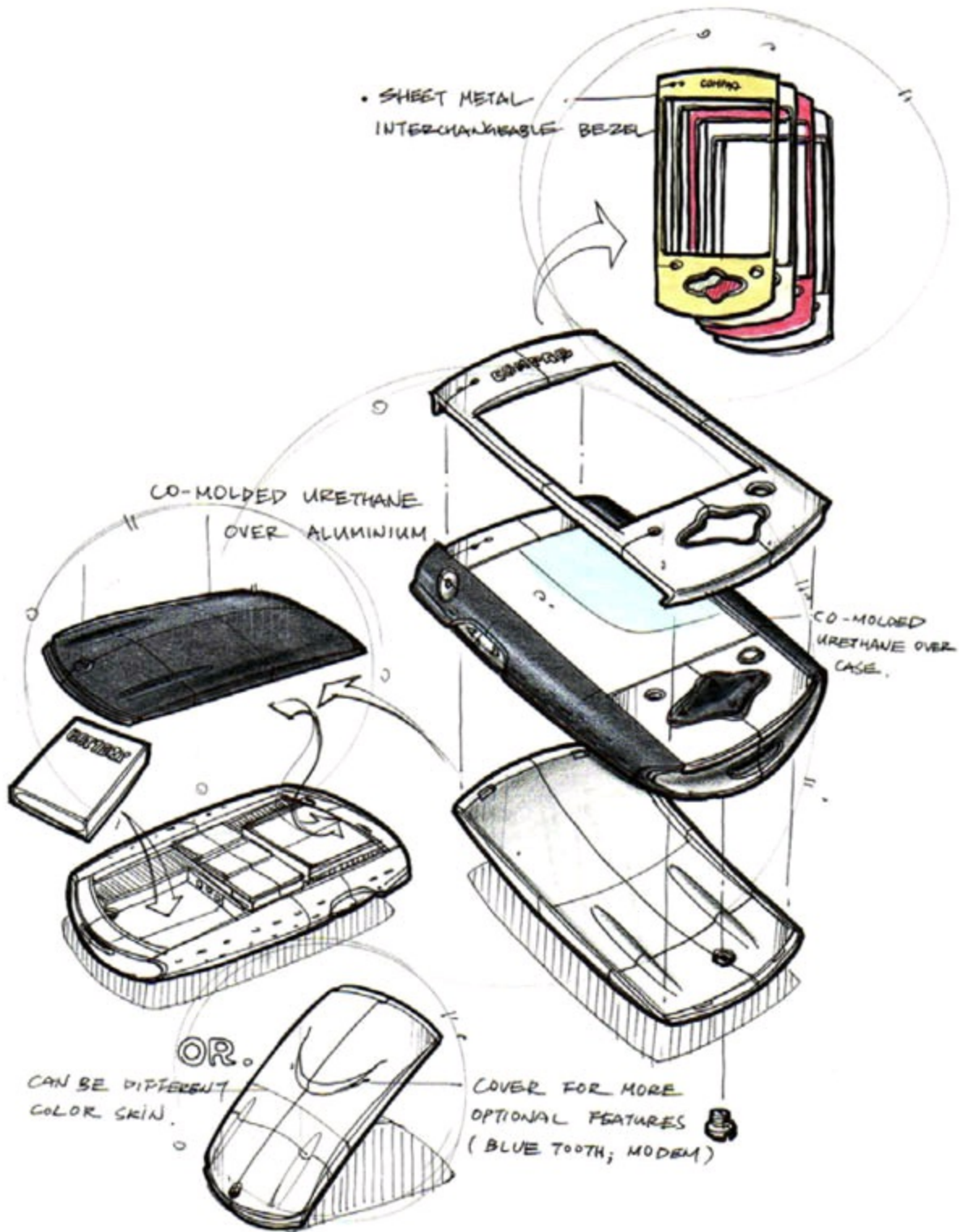

I had explored the personalization options for how the device should be assembled, because the feature jacket concept was the Big Idea of the iPaq.

# CONCEPT 2.

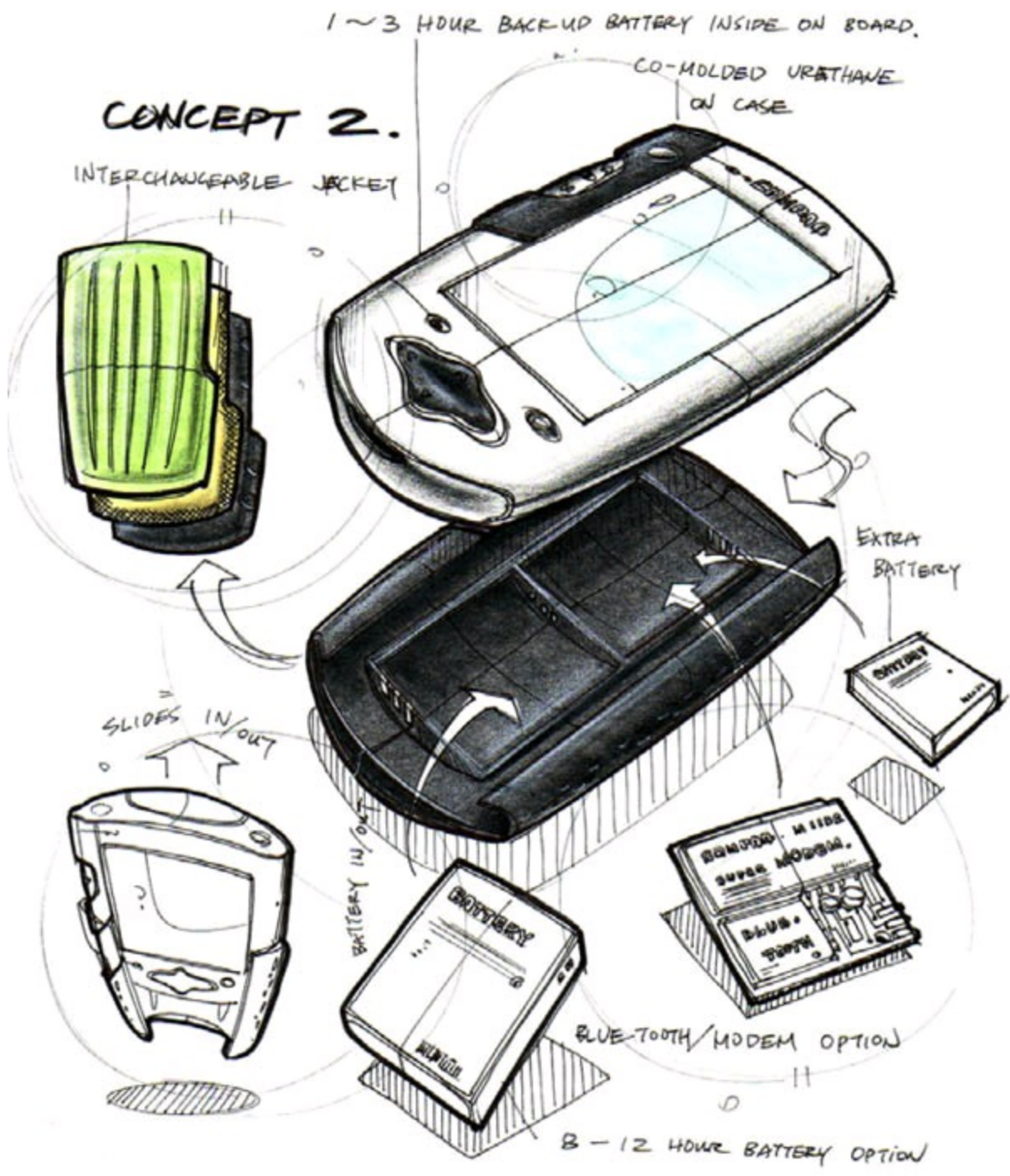

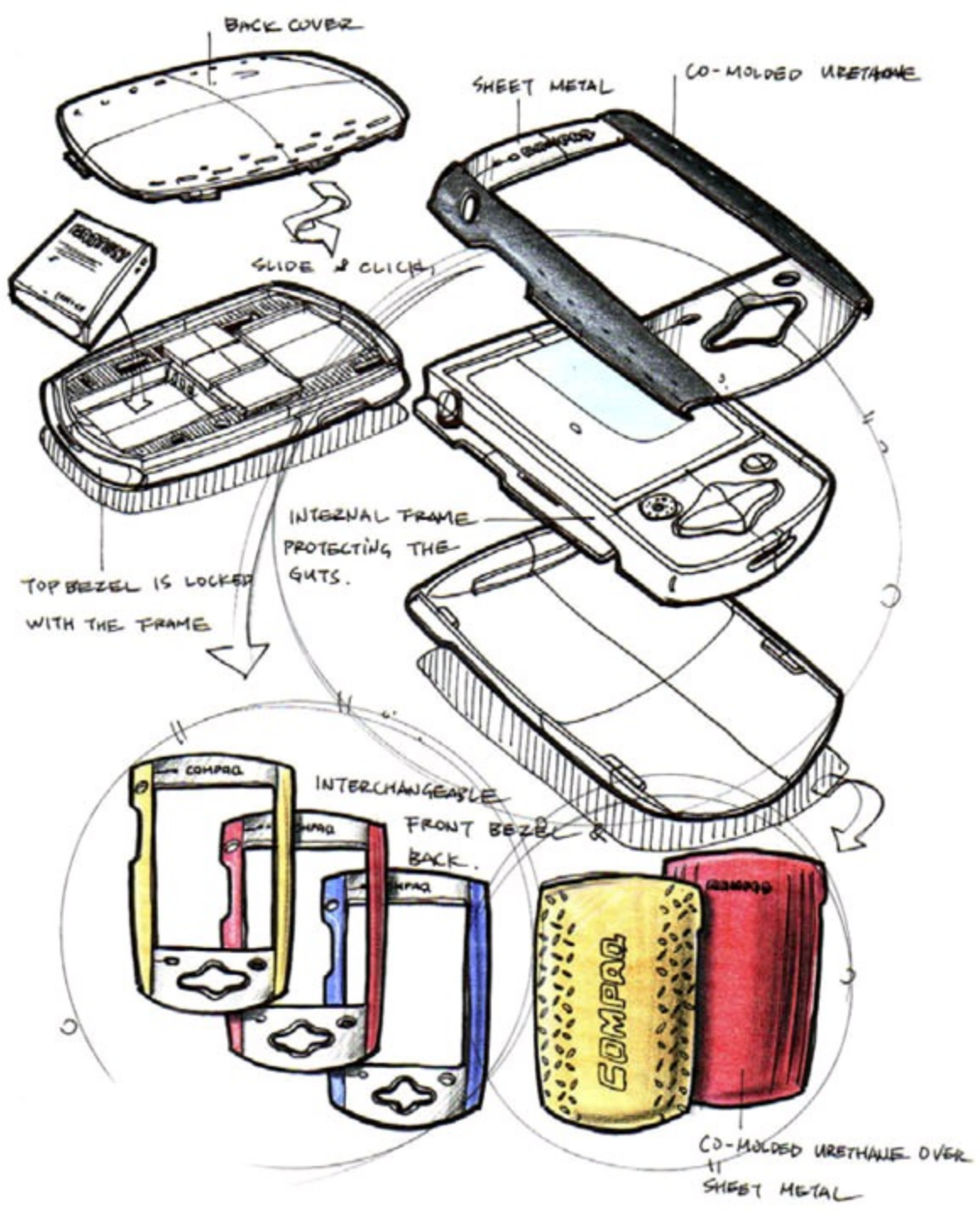

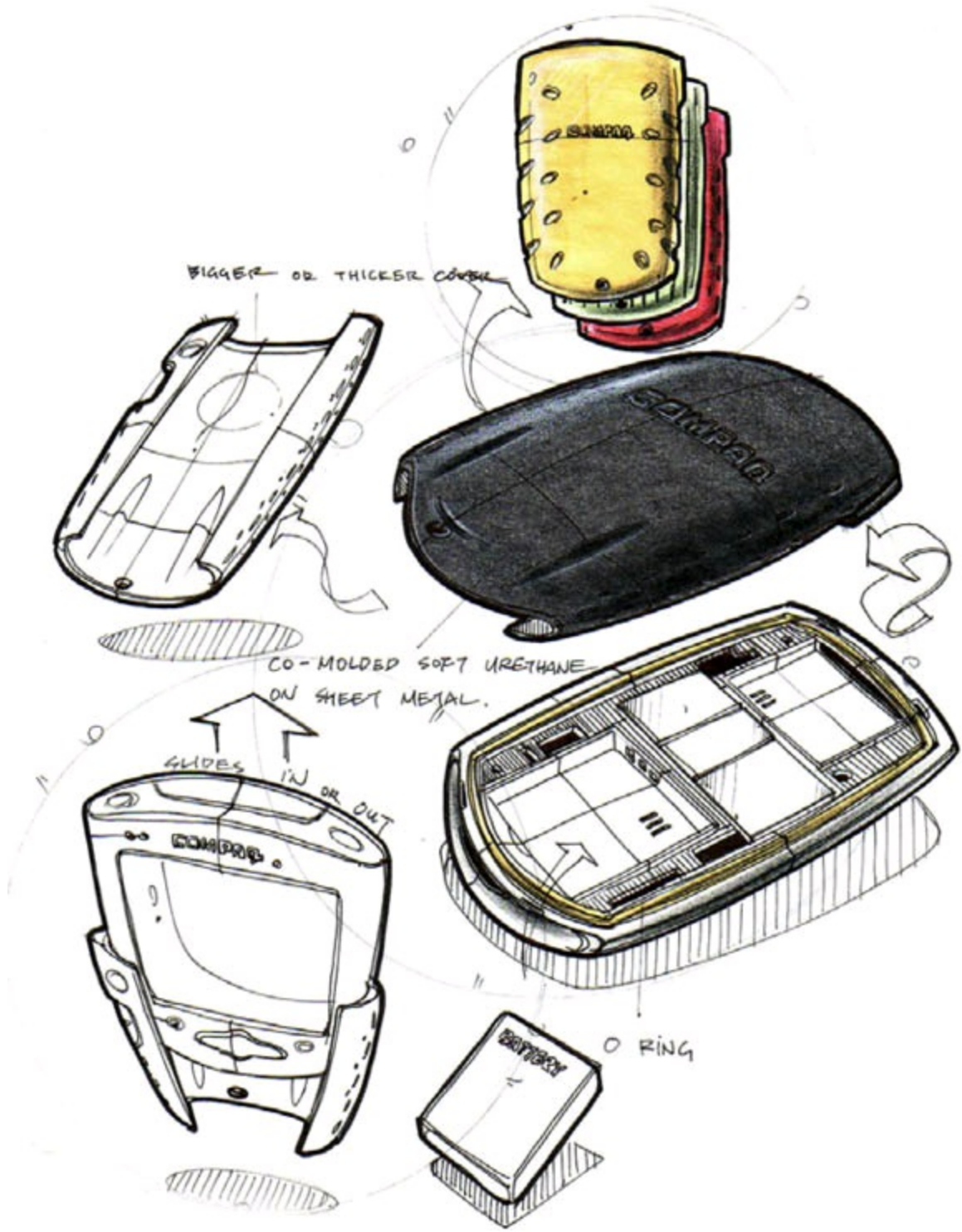



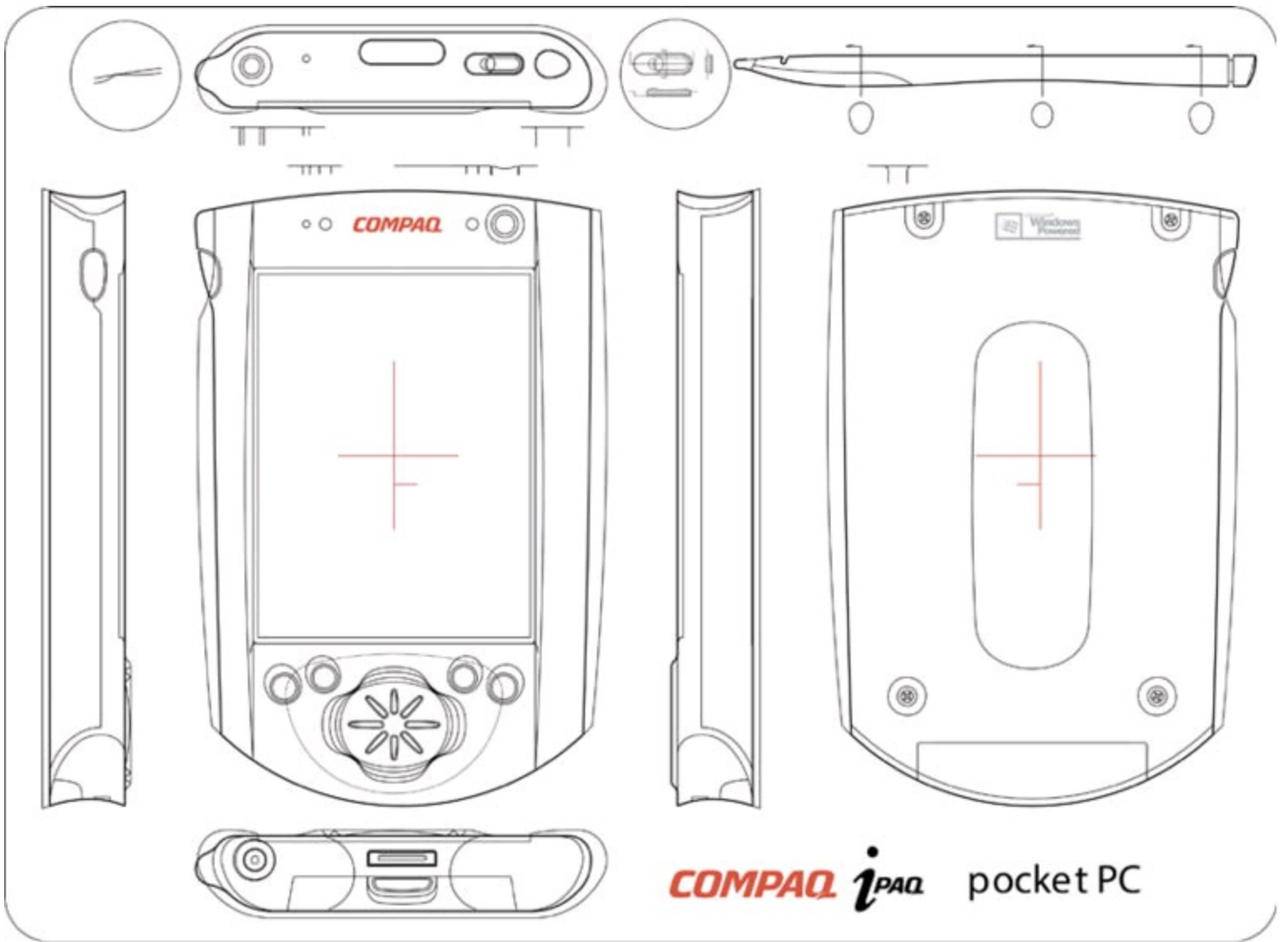

Final ID CAD drawing

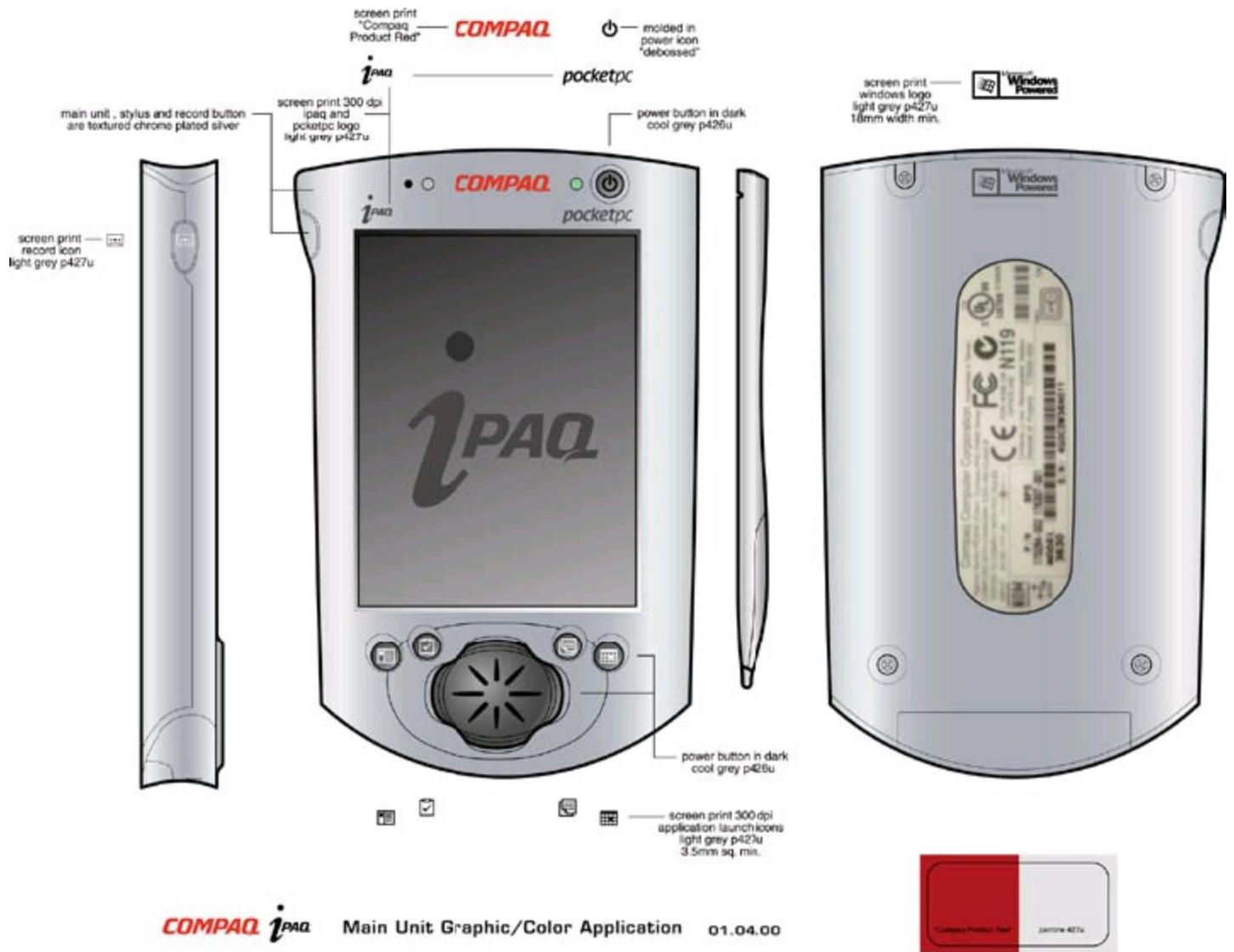

Final product graphic sheet



2D Photoshop rendering



3D rendering



MACAW 10.25.99

3D rendering



3D rendering



3D rendering

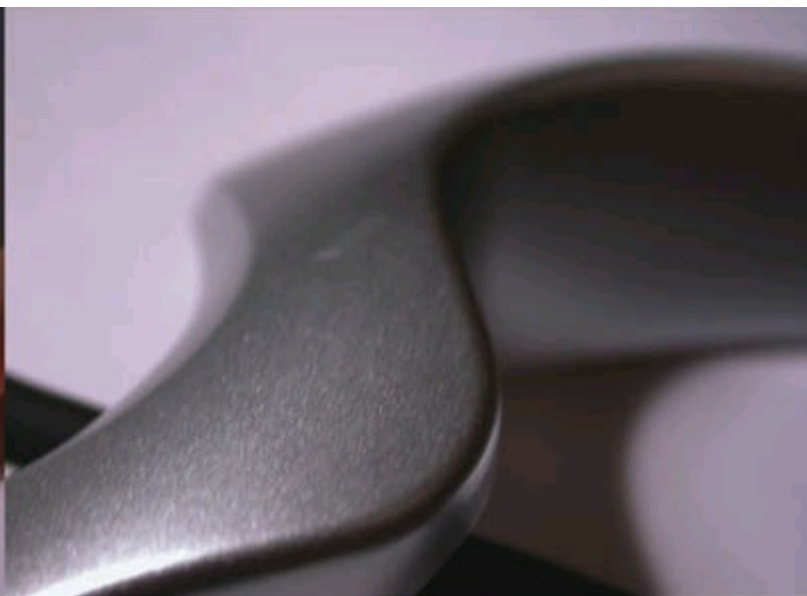

Final product





Final product with a translucent basic jacket



Final product



Group shot



Detail shot of the navigation / speaker

Nike asked Astro to develop their first running watch for creating a new category of Nike product line in 1998. The first Triax running watch was a big success on the market right after it came out. I joined in Astro while the team was finishing up the design. Brett, Rob and Kyle had done an excellent job to seamlessly blend lifestyle, performance and technology into the first running watch. Once again, Nike assigned Astro to continue the glory and to design the next generation running Triax 300 watch. As a fresh but green junior designer, I was lucky enough to work with Rob and Kyle to design a new and improved running watch. The challenge for us was to retain the same spirit of original design accent but create another high tide.

The mission was quite clear to me; I needed to find the key for a new opportunity. I figured the first Triax watch was mainly aiming for more serious runners due to its part break, color combination and overall look and feel, so I went around Nike retail stores asking for who was buying these running watches. Were they really hardcore runners or joggers? According to the feedbacks, even though the watch was selling well, I found out many casual joggers and sport enthusiasts loved the watch but hesitated to buy it because of its professional look. Therefore, I thought about taking an approach for casual wear, so it does not so intimidating to the majority. Since Astro had worked with Nike for several projects, we seemed to have great confidence between two teams. A good thing to work with another design team was the design communication was rather easy, because we spoke the same language. Unlike working with a business team, a design consultancy often needed to prepare extra presentation materials to explain design process or design philosophy. In this case, designers were exchange ideas and feedbacks frequently with rough sketches through emails. This working method was time saving and effective. Once we got a consensus about the general design directions, we started 2D CAD drawing and rendered it with Adobe Illustrator. We also did quite a few form models in our little workshop to check if the designs were working. Those form muckups were 2 to 1 in scale so we could really dial in the details. Kyle was our model making master. I learned many model making tricks from him while working on the form models. I personally thought the model making was an extremely important design process to a designer; it helped designers to figure out

design problems and sometimes brought surprises to the original design. Although 3D computer model making was quite effective as well, it could never replace the real touch and feel of model making by hands.

The big idea of the final design concept was to design a total integration time piece which was not only an integration between the watch and human body but also the watch itself. My design approach to the Triax 300 was a more elegant yet still sporty look and feel. Triax 300 was the first watch to use co-molding process to mold the watch band with the watch movement housing at the same time. The advantage was great duration and no color matching problems between the band and the watch. The oversized display was tilted to 23 degree for even better visibility while running and glimpsing the time. Polished and anodized aluminum bezel gave a high finish and high end look as well as prevented the watch from scratch. The polyurethane rubber band wrapped around the big crystal display and formed a complete loop implied endless time movement. I also explored many concepts of new fasten systems and manufacture possibilities for the future design references.

Nike was very pleased with the final design. The Triax 300 continued the glory and once again proved as a big saler. To date over 300 million in category sales world wide, the Triax series has won numerous international awards.

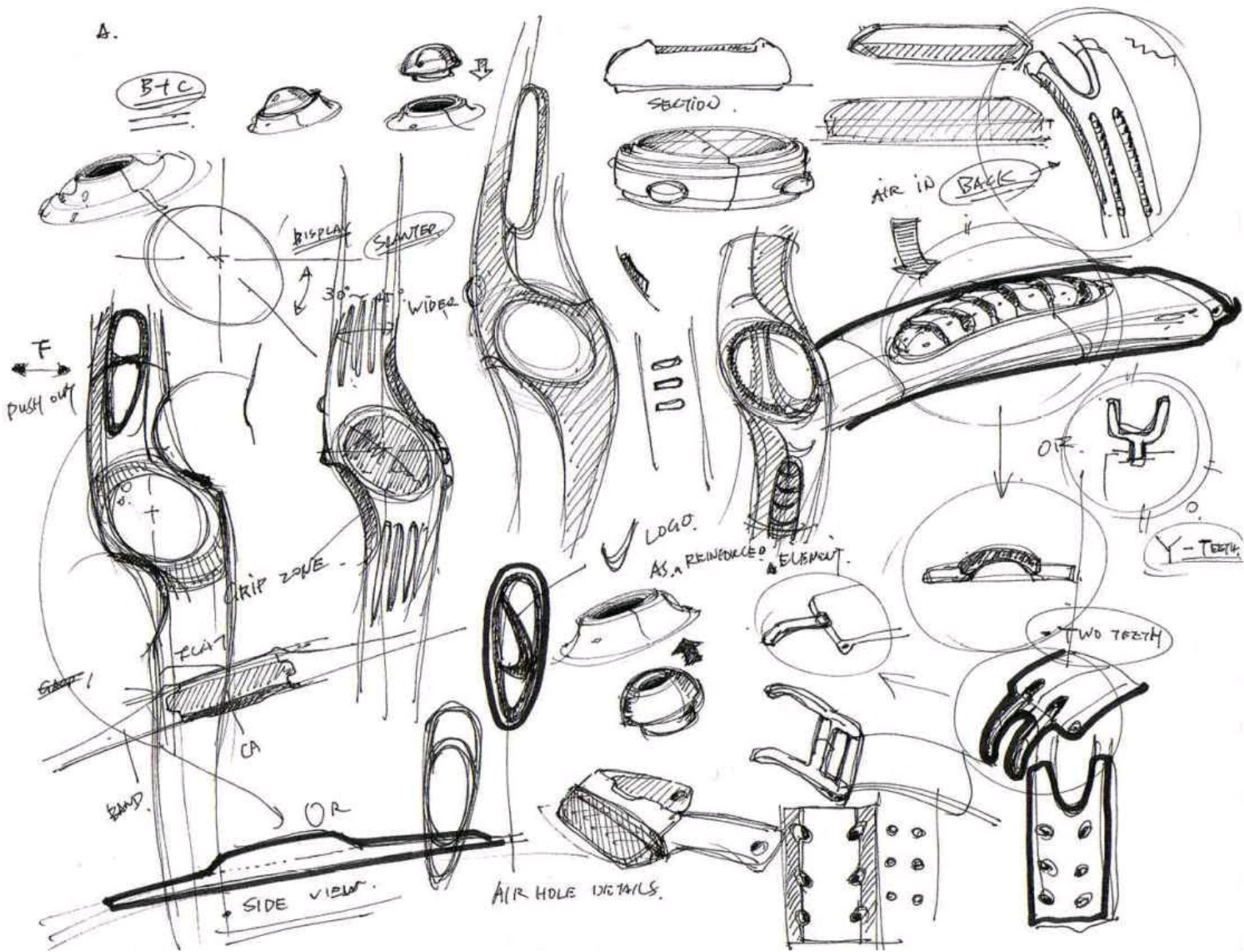

Translucent co-molded rubber insert to make the band look lighter

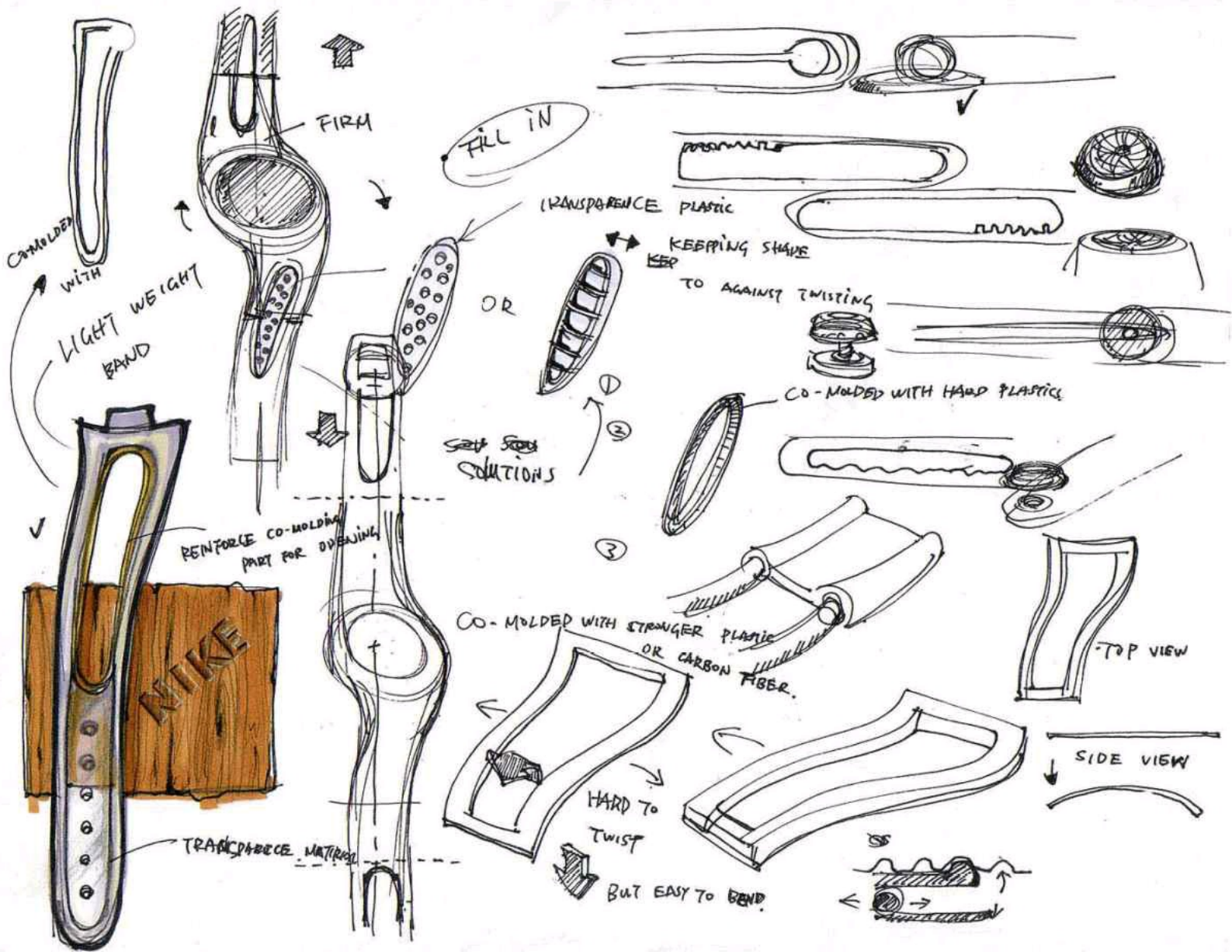

Translucent co-molded rubber insert to make the band look lighter





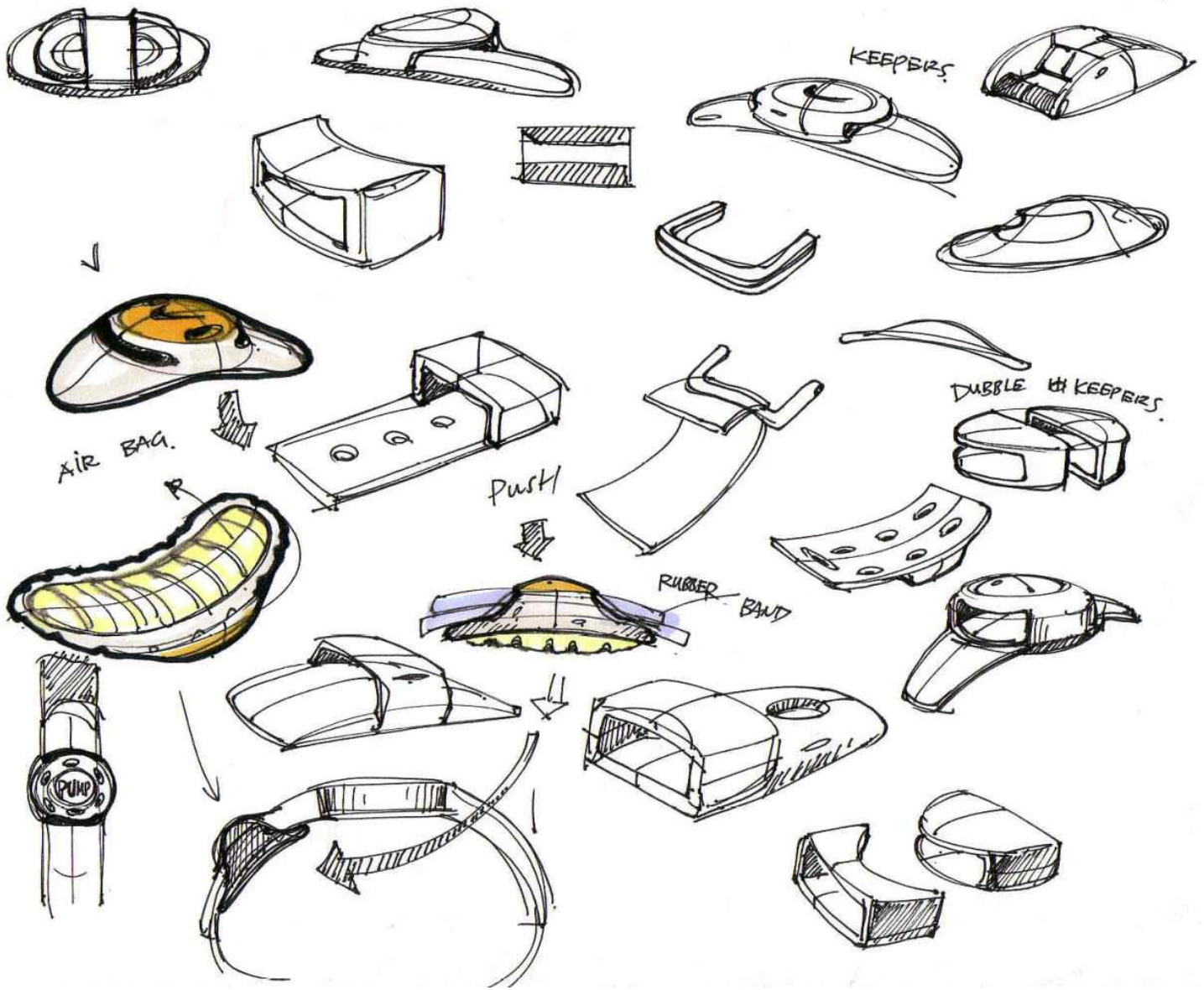

Air pump idea for tighten up the watch band so it does not get loose while doing sports

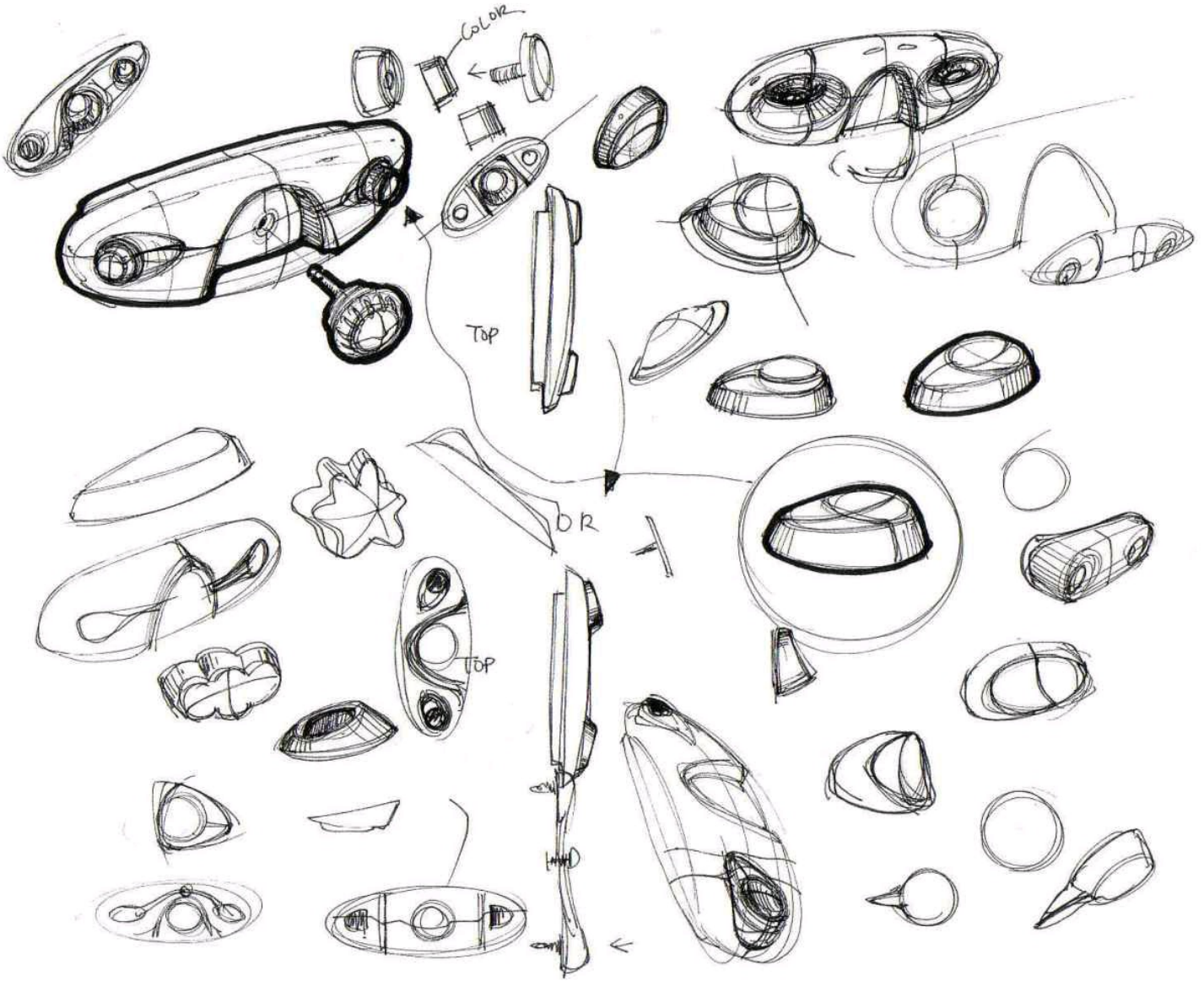

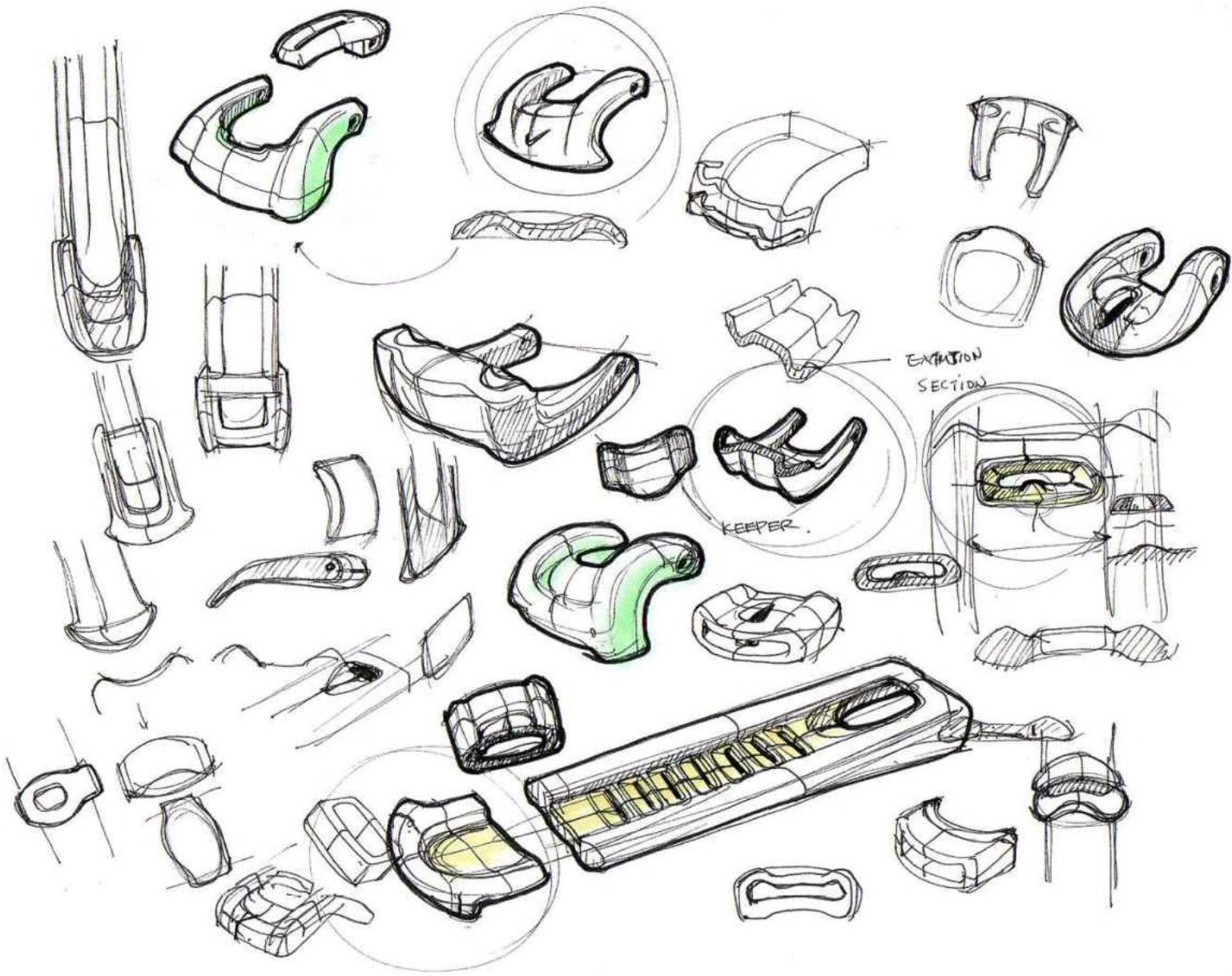

Detail on the female watch. This Watch buckle went better with the final watch design.



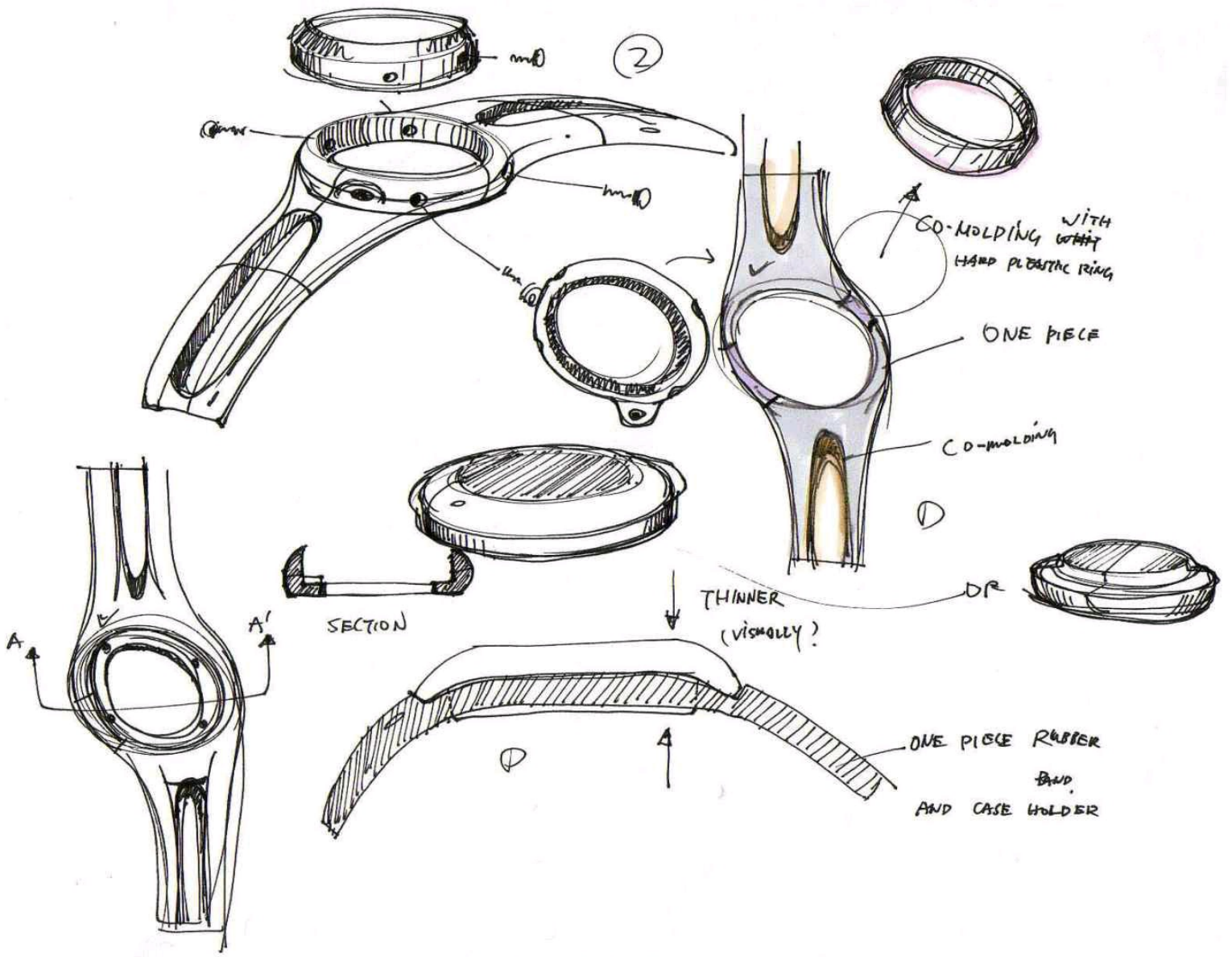

Early concept of separating the movement and the watch band.



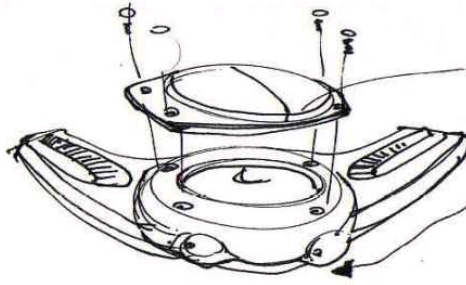

11LD  
MAYBE?

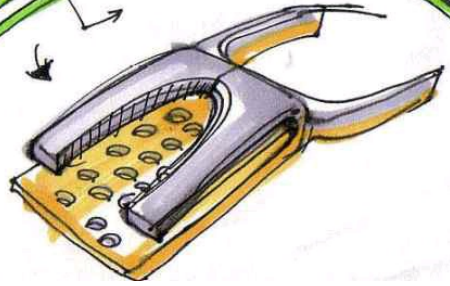
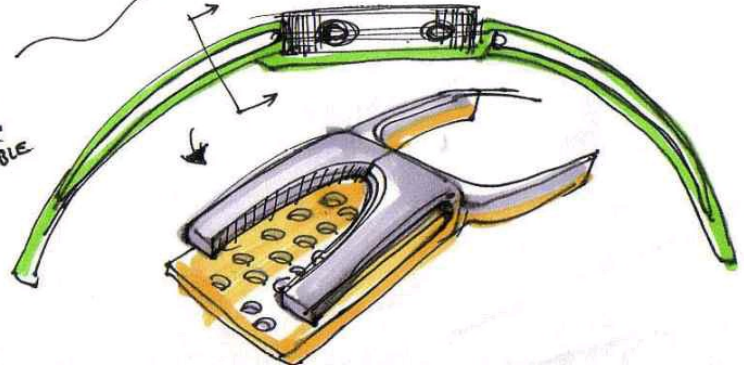
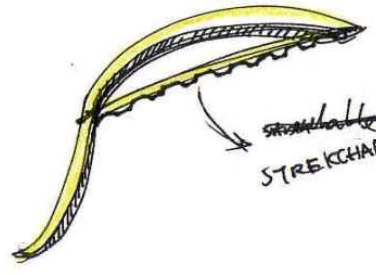
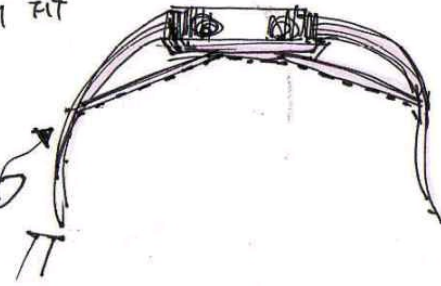
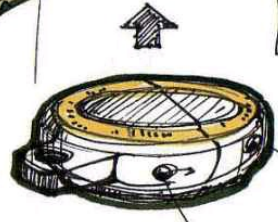
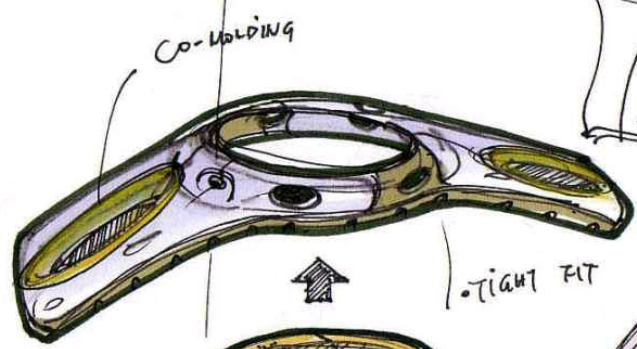
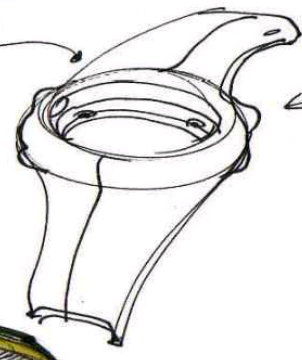



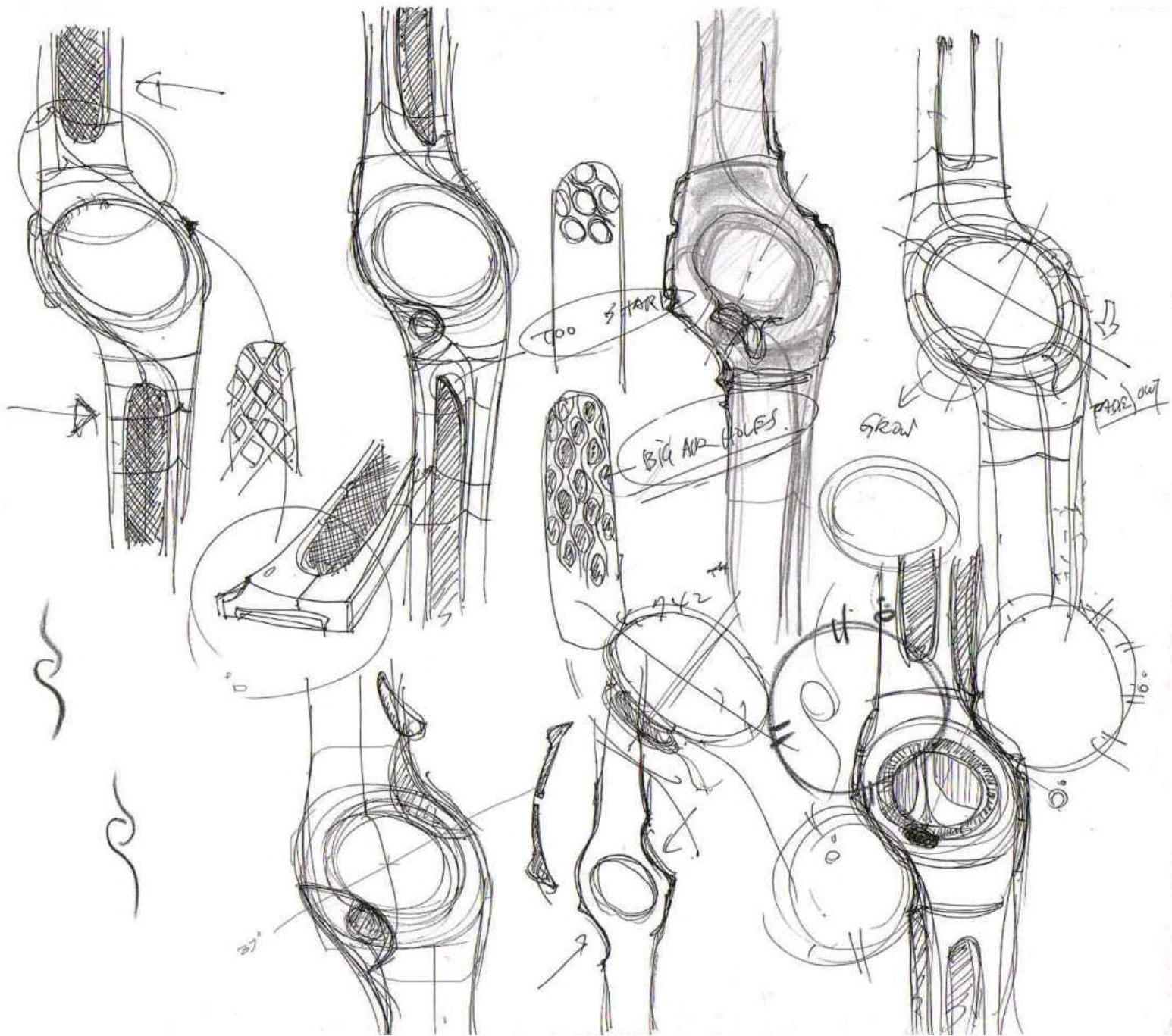



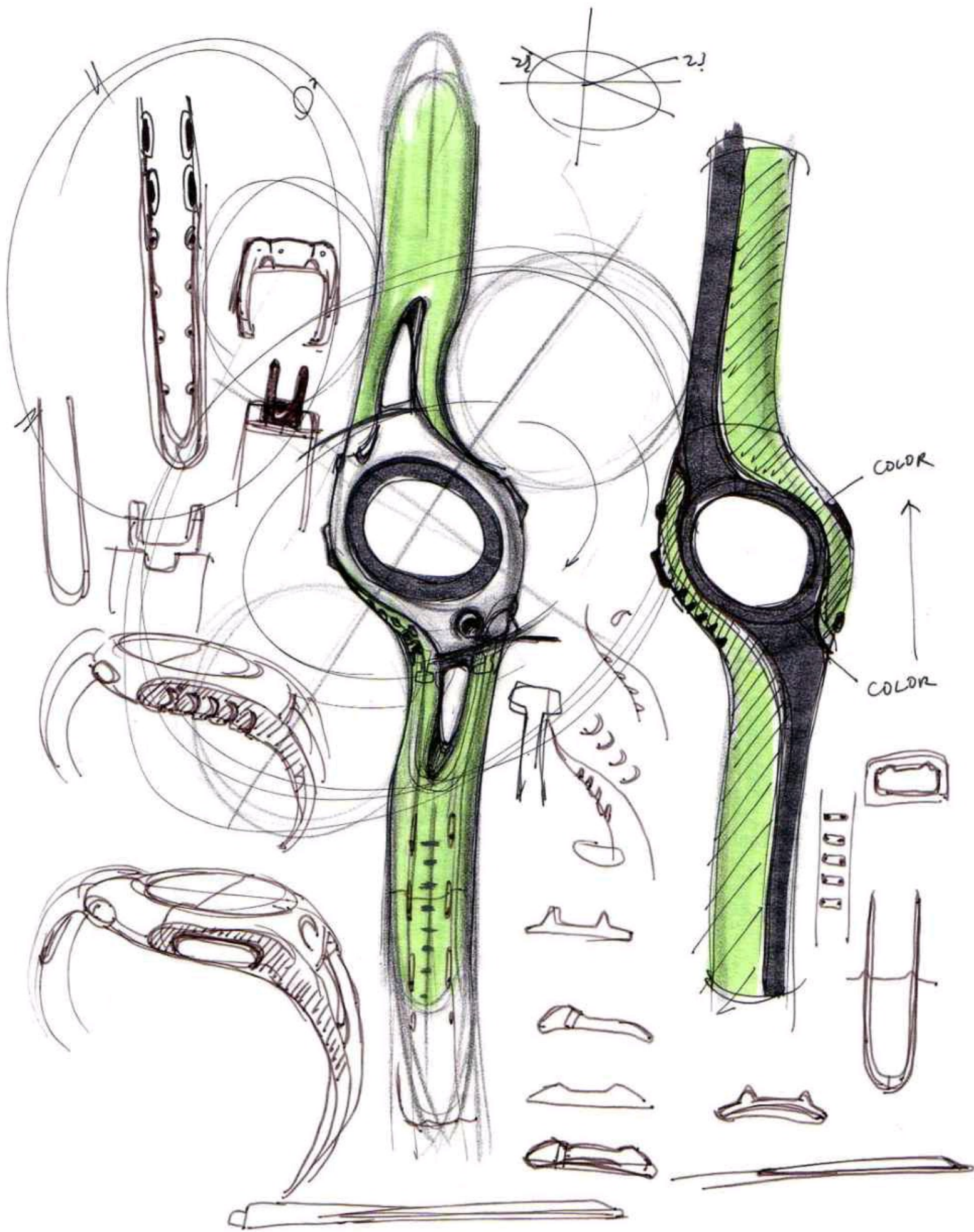

Grip zoon detail. One of the early concepts.



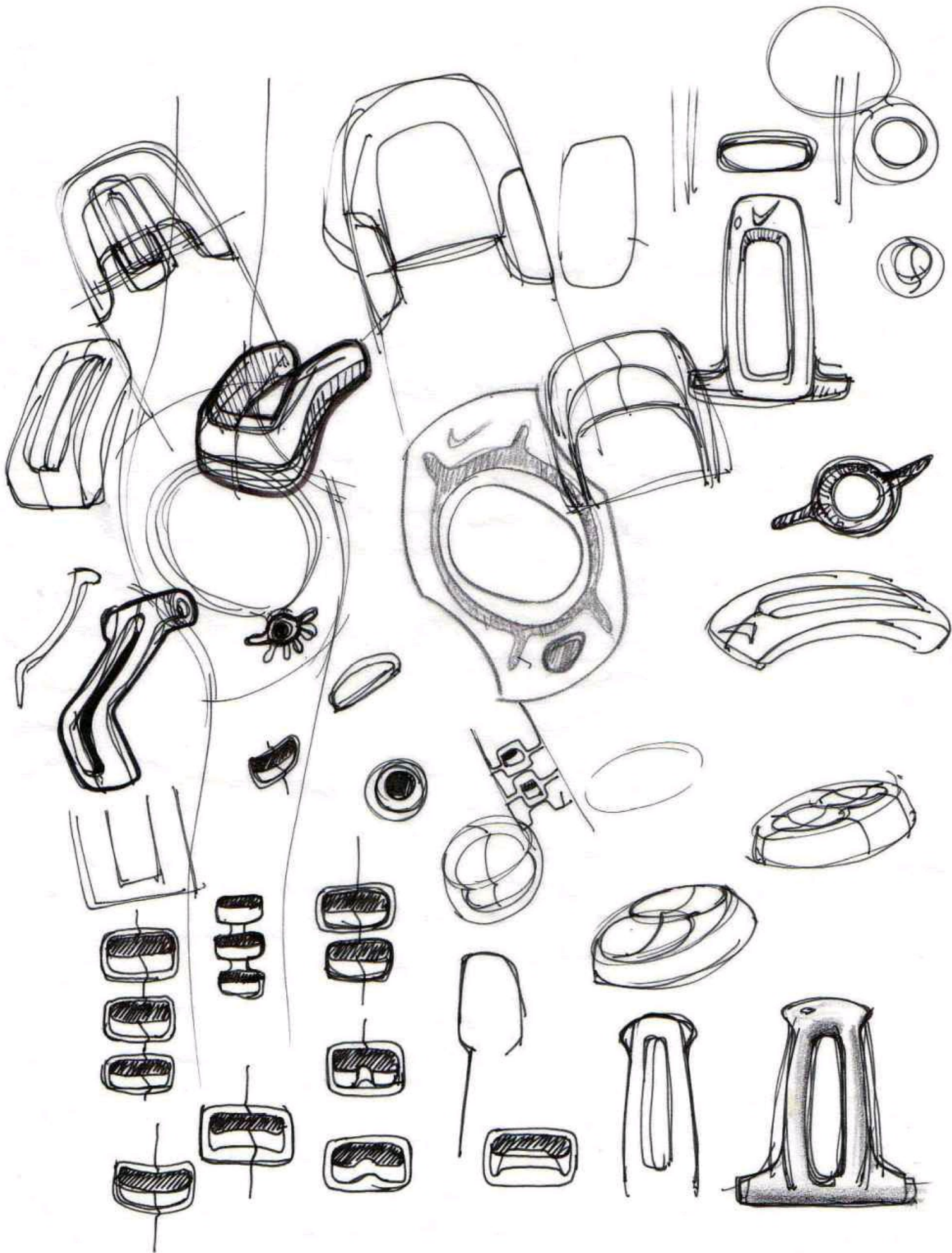



(L.P. mm)

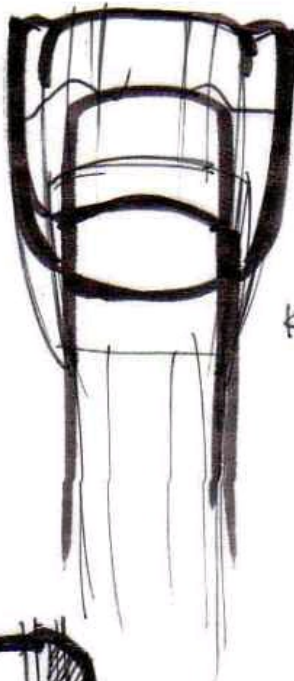
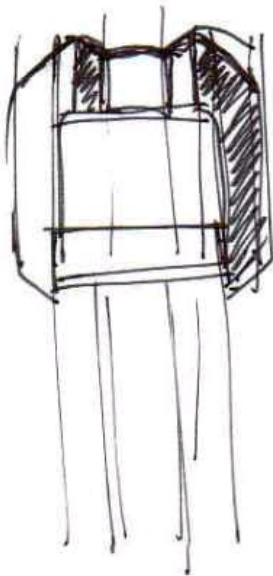
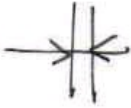

KEEPER

SECTION

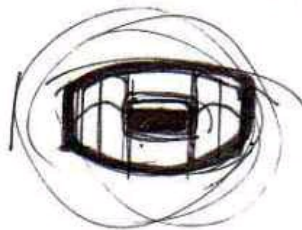
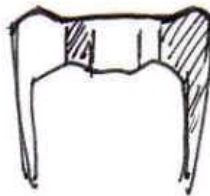
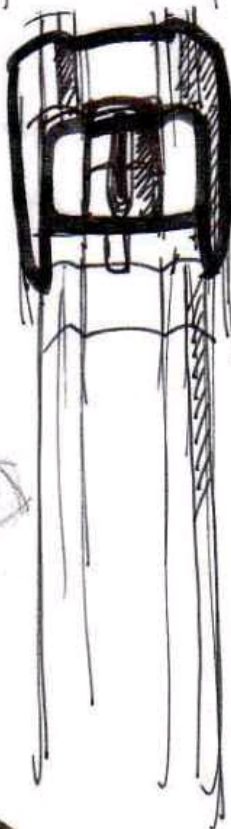
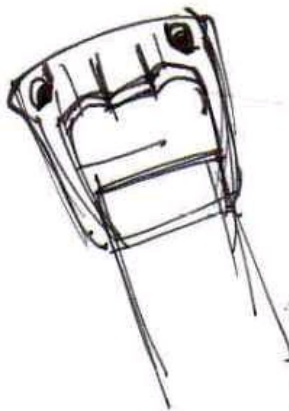
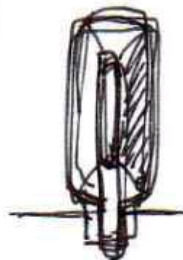

KEEPER







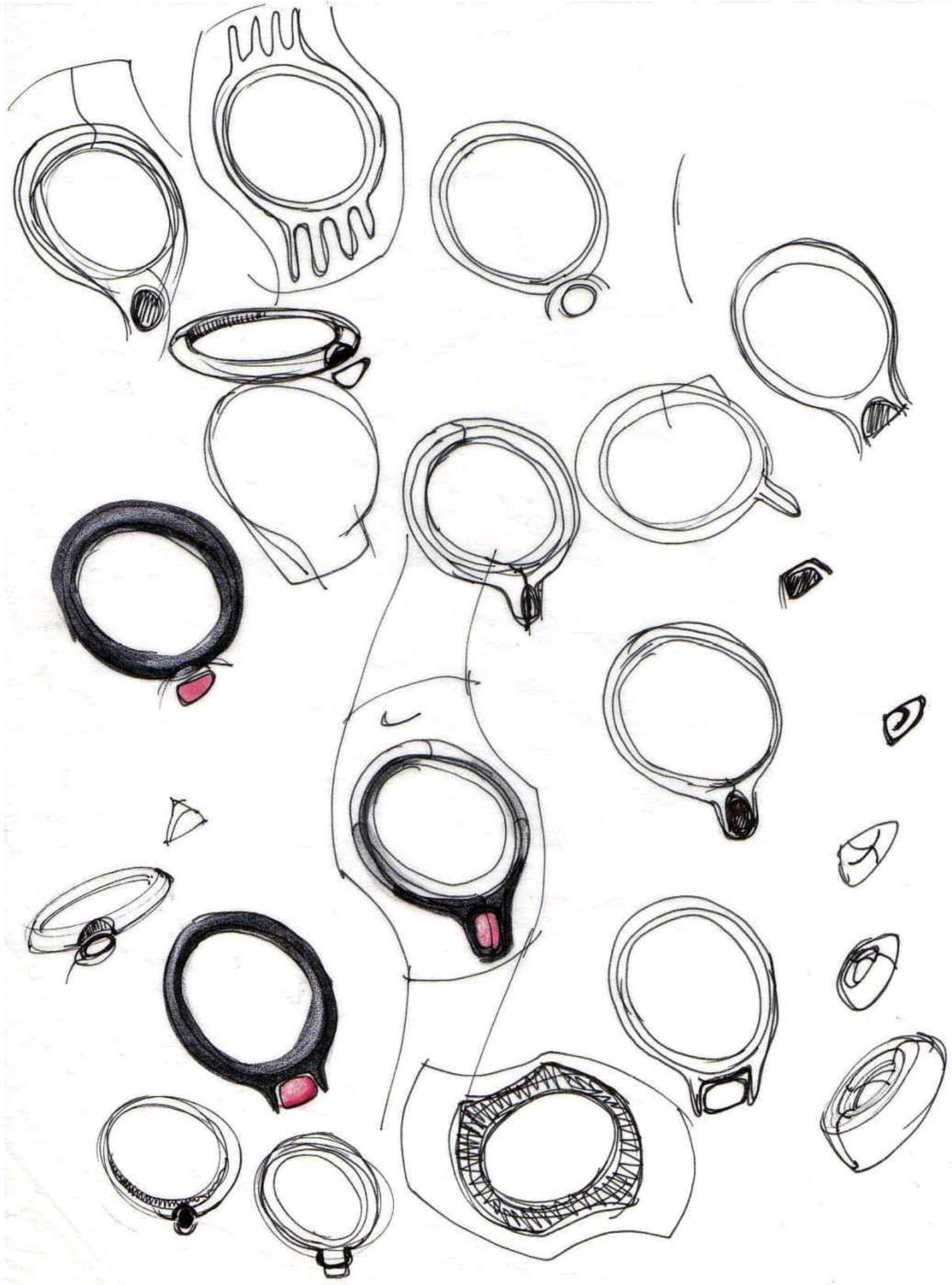

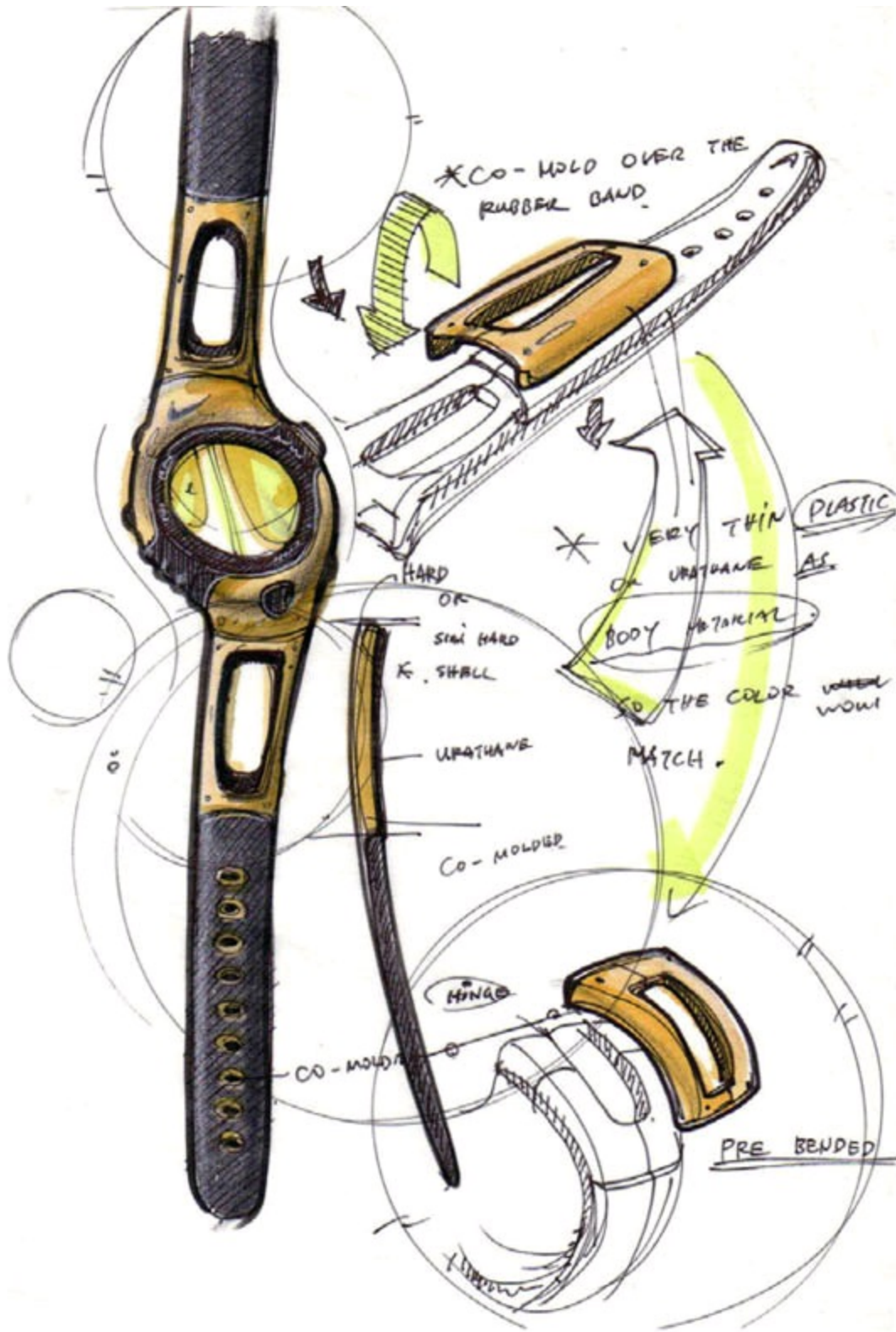

Plastic shell molded over rubber band.







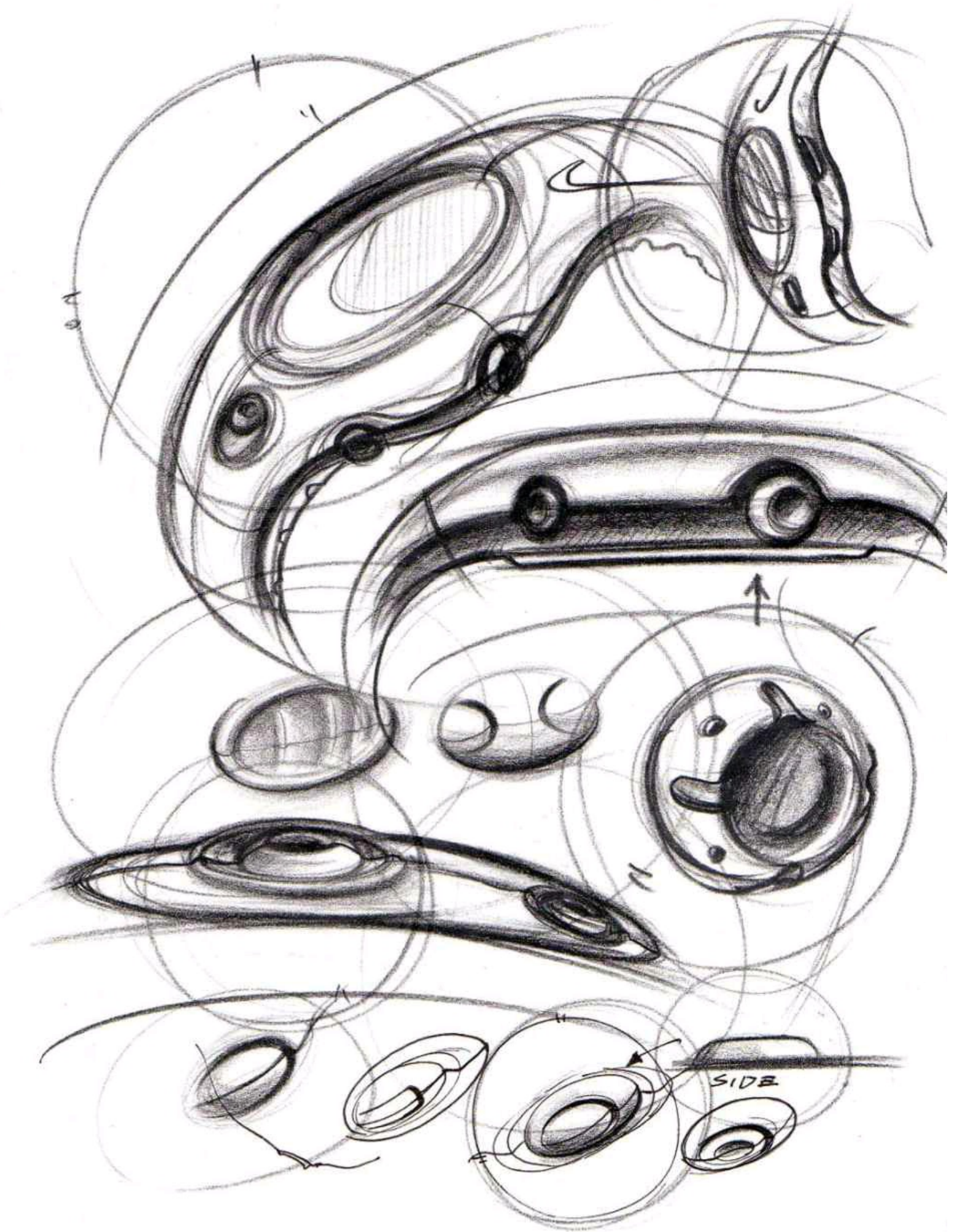

Designs for the side button.





COOL!



CO-MOLDED

TWO  
TONE.

Two-tone rubber to make the watch look thinner.



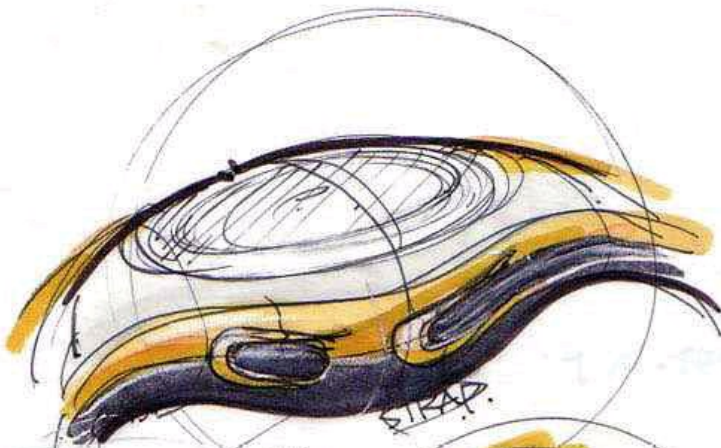
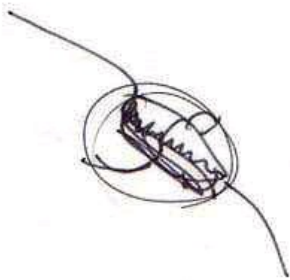

CO-MOLDED

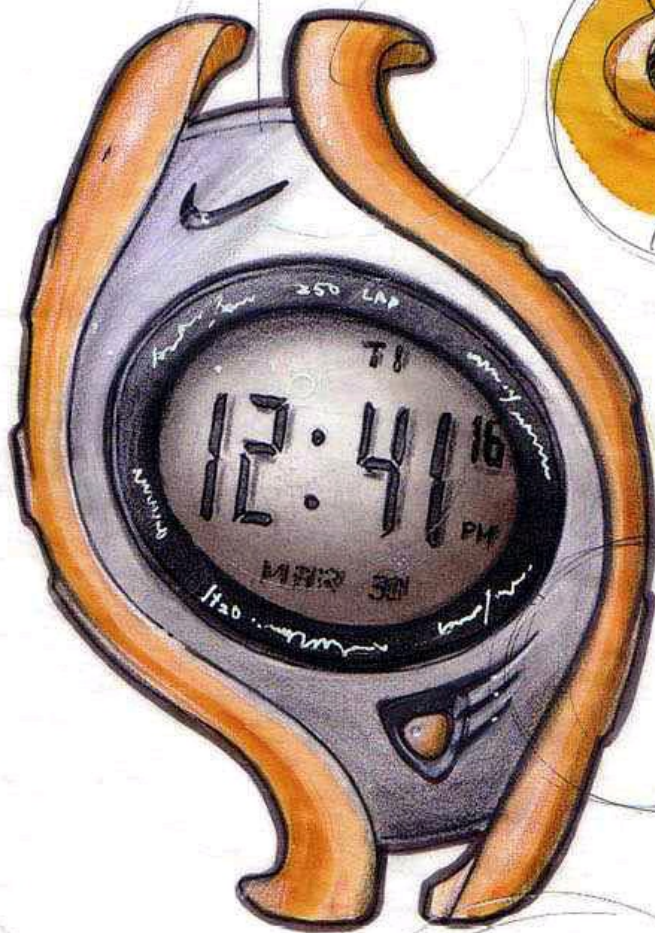
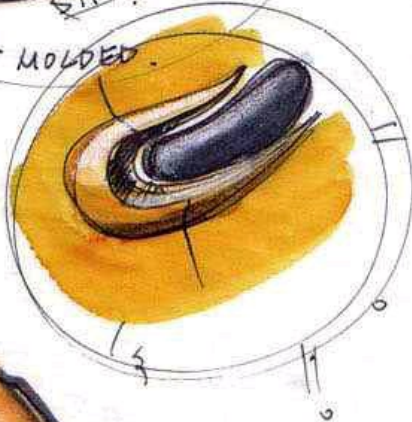

OR



ONLY ON TOP

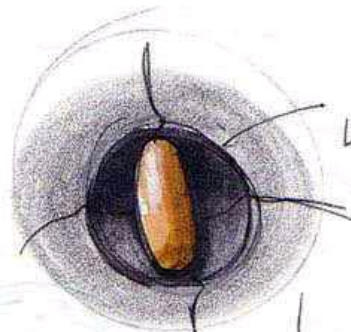
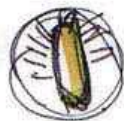

LIGHT B.

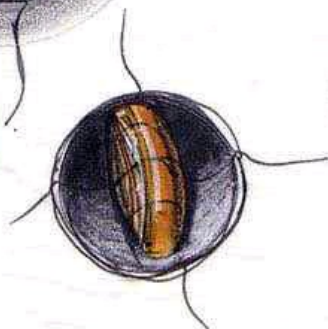
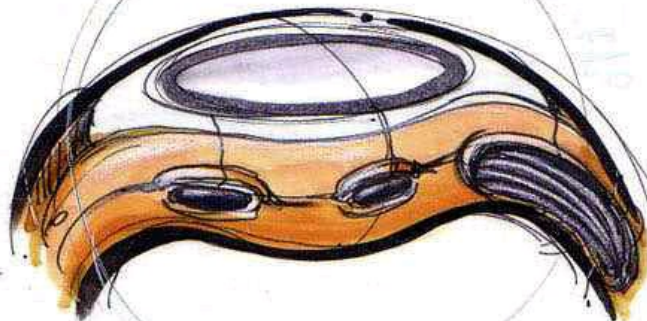

To attract the projected target group, stamping metal bezel decided to be an important element for the final design.

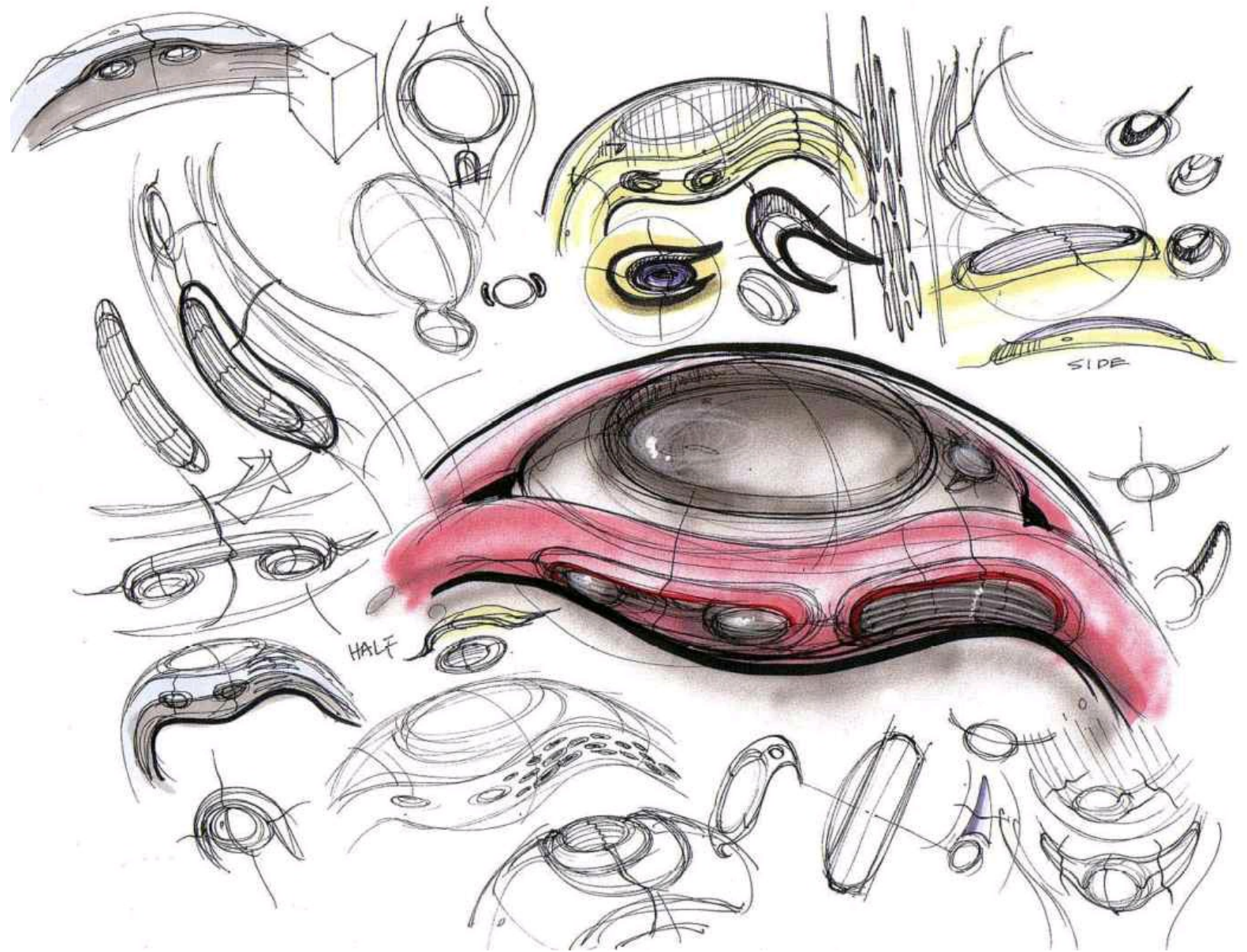

Cool factor: Open the jaw to load rubber rings..

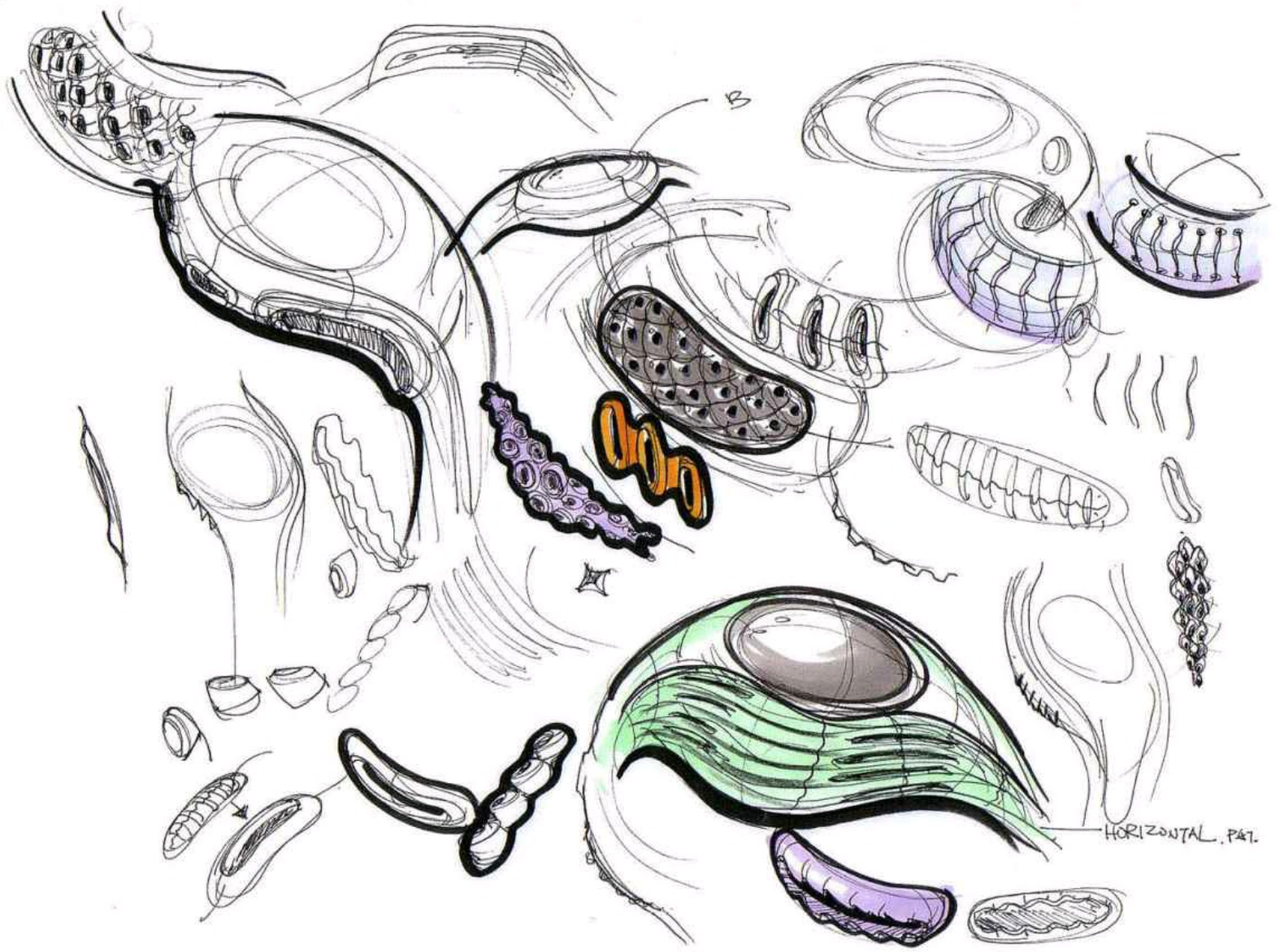



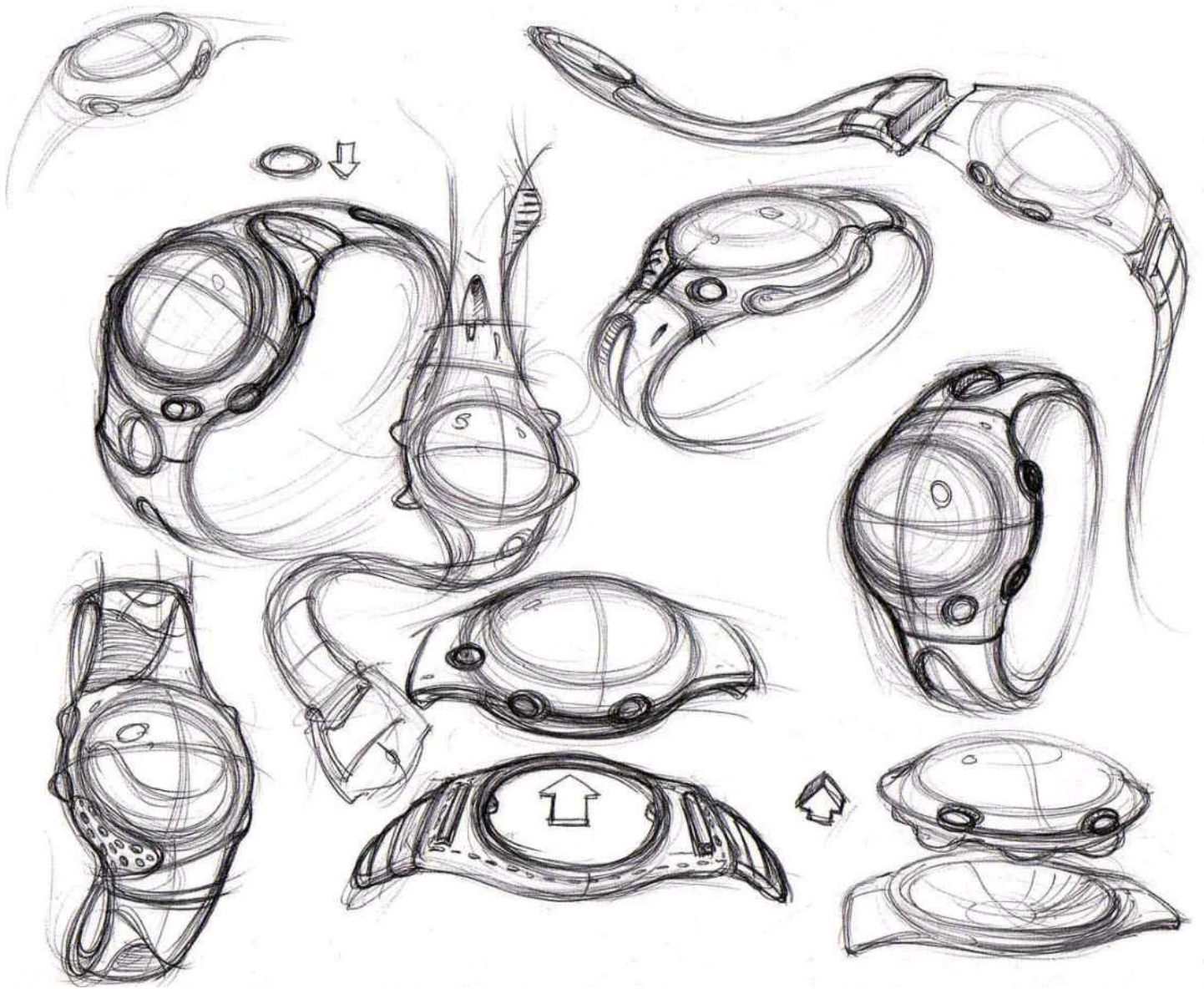

TRANSLUCENT SOFT PUROMETER

• TOP VIEW

RELEASING BUTTON

\* RELOCATE THE  
BUTTON TO FIT

FISHING WIRE

• TURN

\* TURN TO TIGHTEN UP

• HOOK IT UP

1.

• MICRO ADJUST

2.

CO-MOLDED AIR HOLE

• EXPLODED VIEW FOR THE BUCKLE

# LOOP.GPIN.HOLD

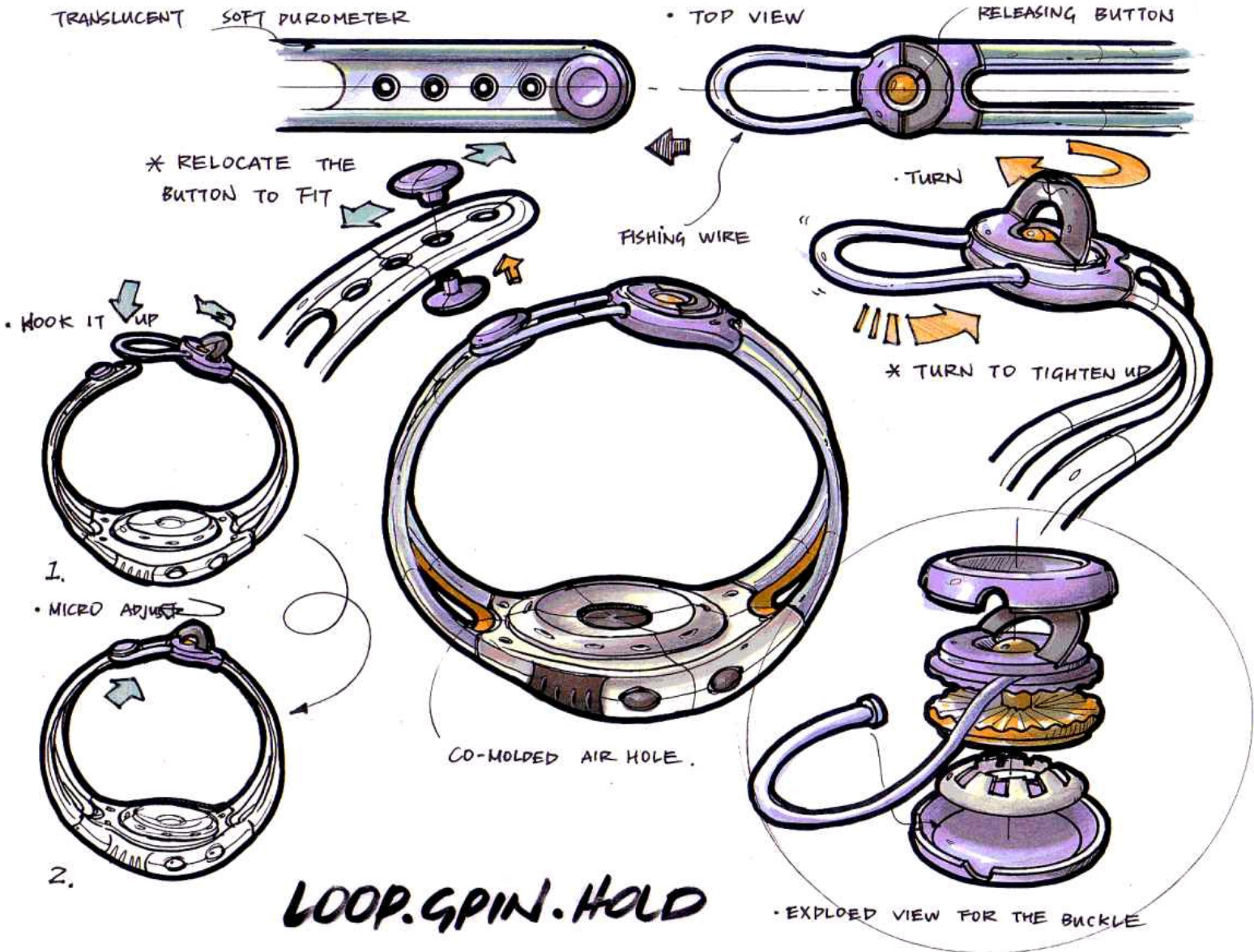



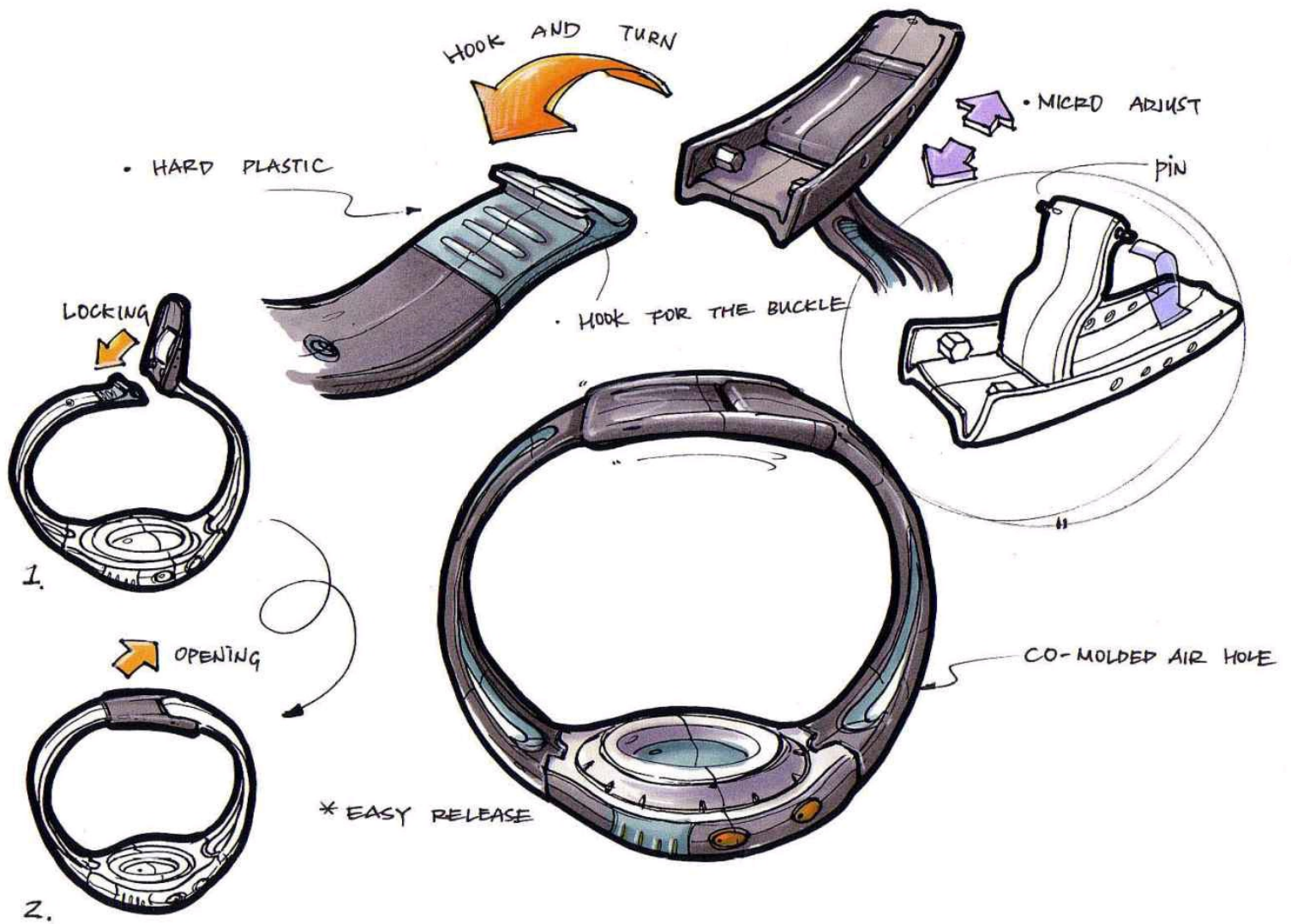

# BUCKLE + RATCHET



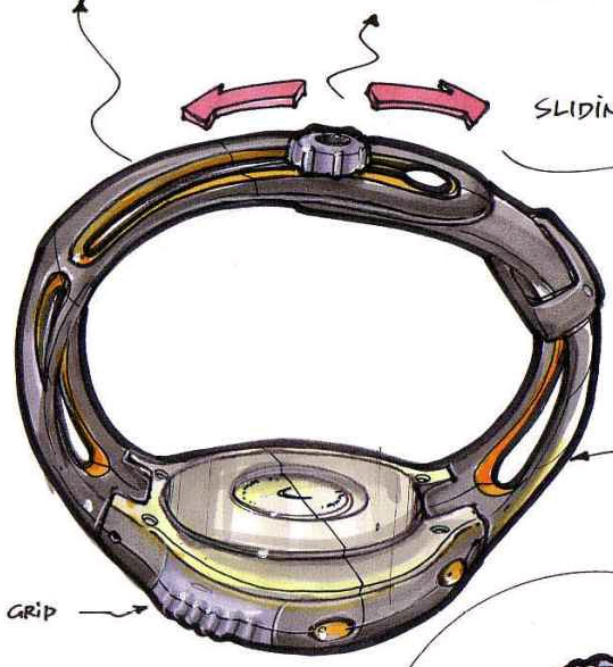
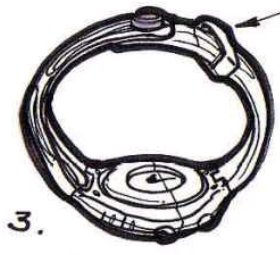
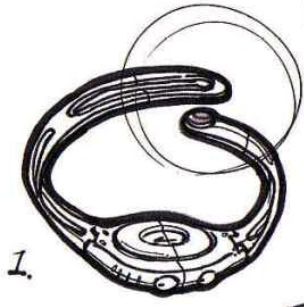
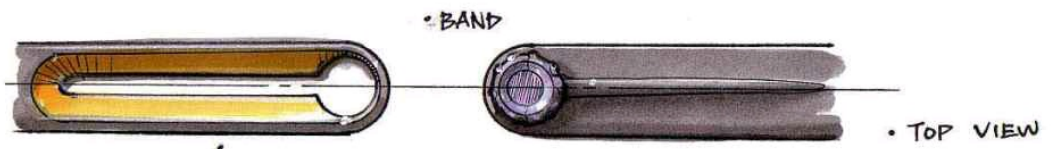

\* STEP 1 2 3.  
WAY TO SECURE THE  
WATCH ON YOUR WRIST.  
\* EASY ADJUST

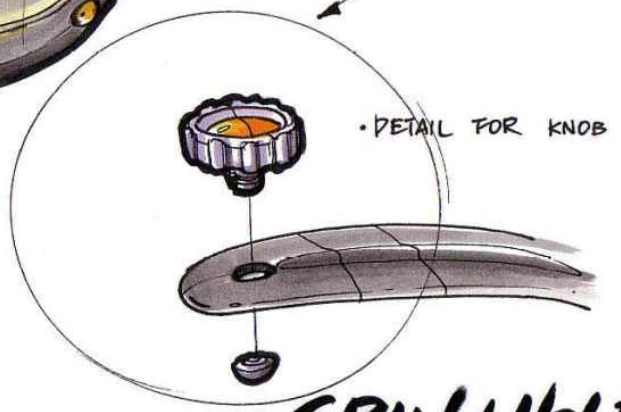

**SPIN + HOLD**

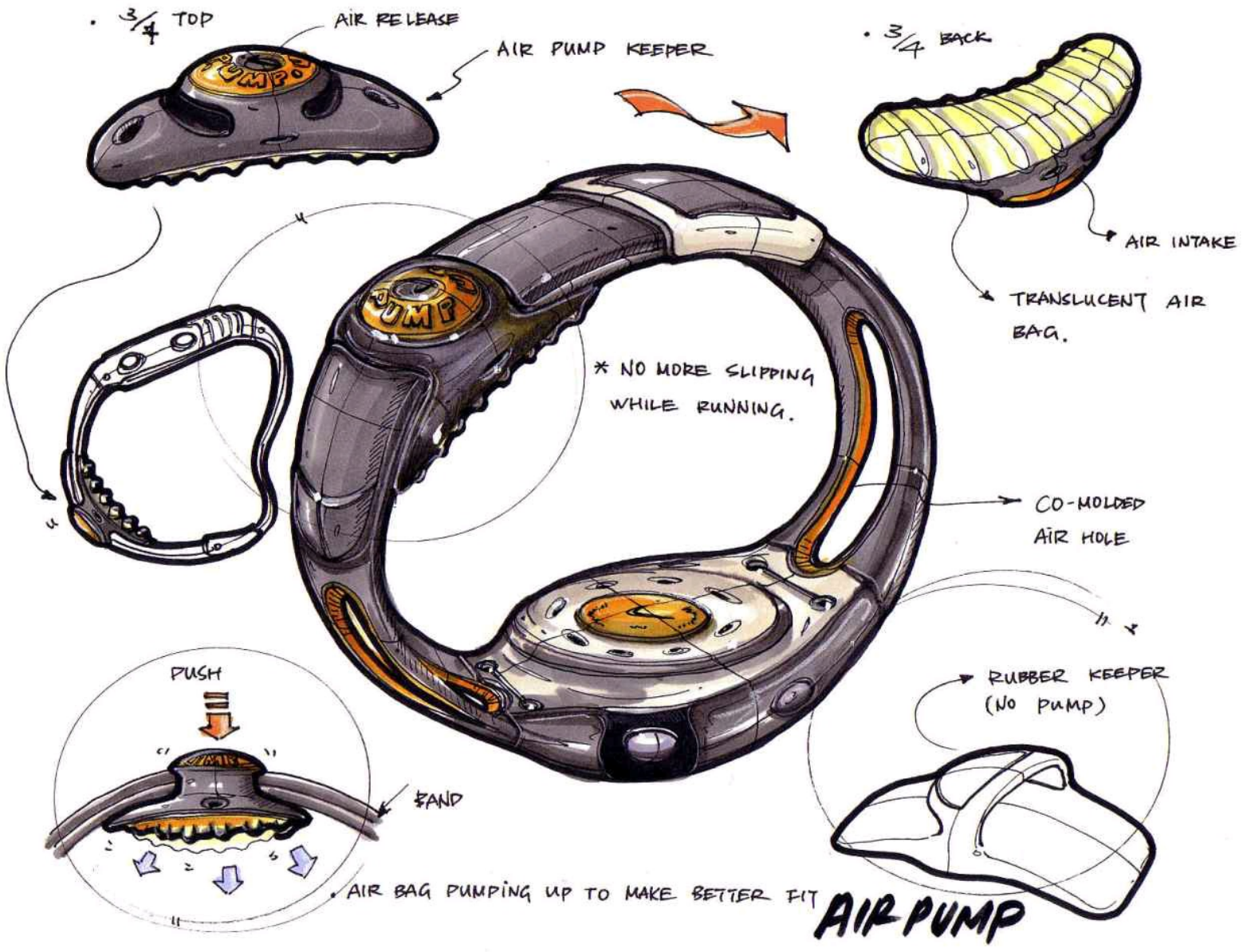

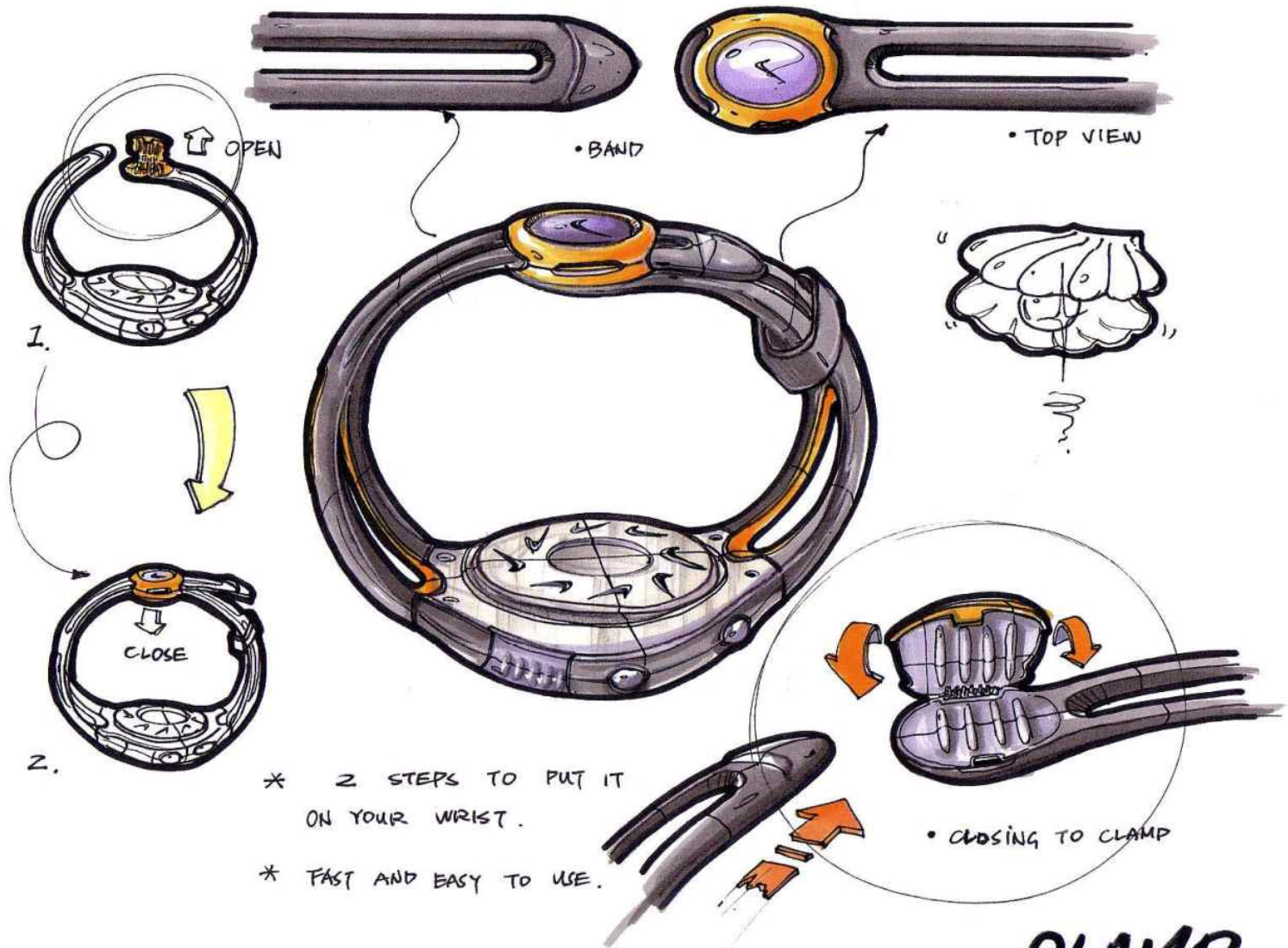

\* 2 STEPS TO PUT IT ON YOUR WRIST.

\* FAST AND EASY TO USE.

# CLAMP





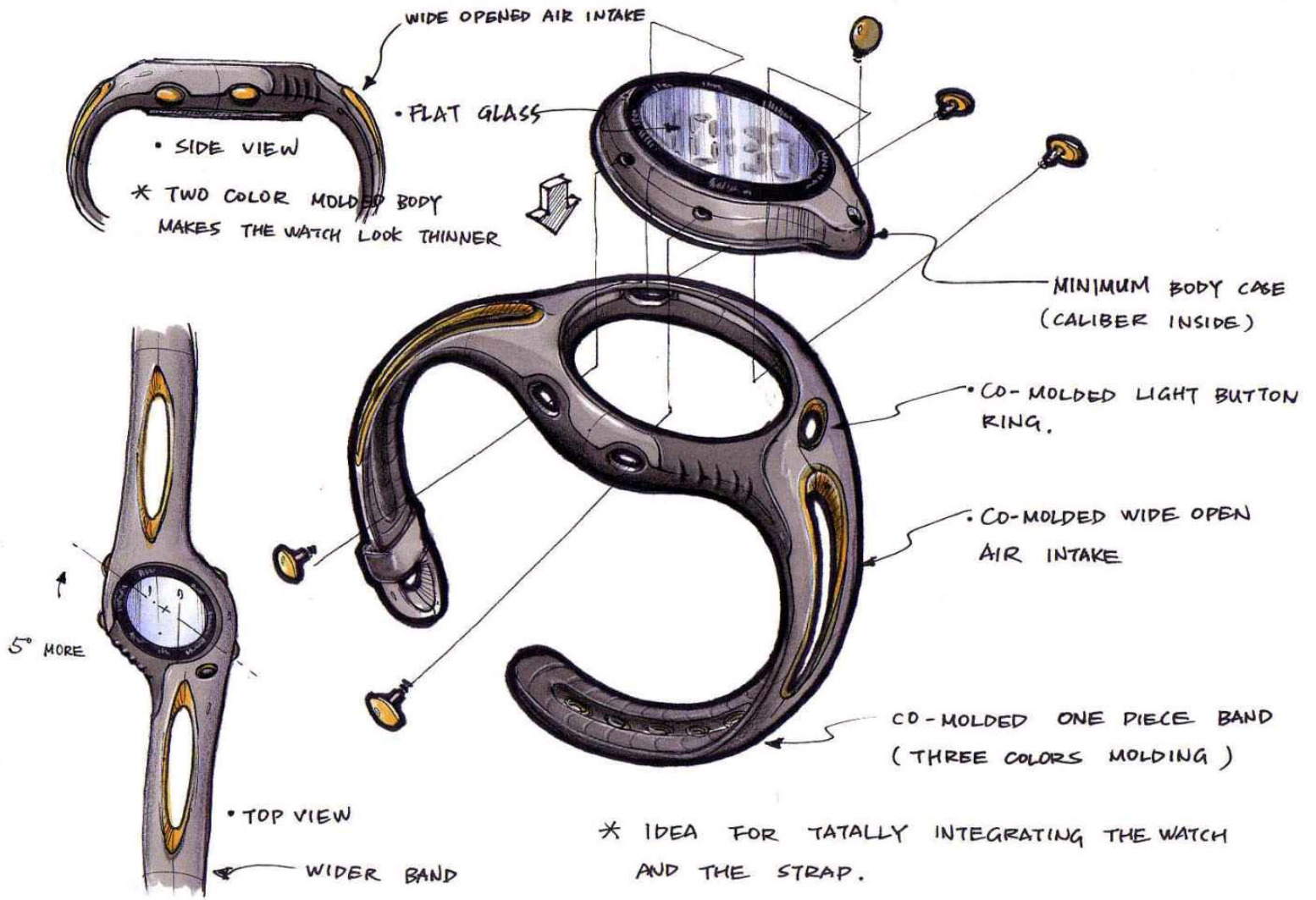

**JACKET**

• TOP VIEW

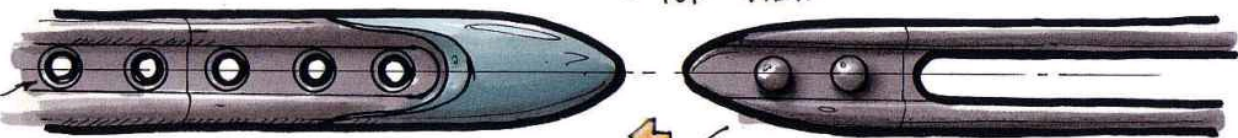

CO-MOLDED HOLE RINGS

\* SNAP INTO THE PROPER HOLE

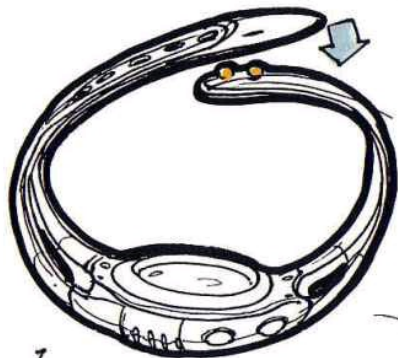

1.



2.

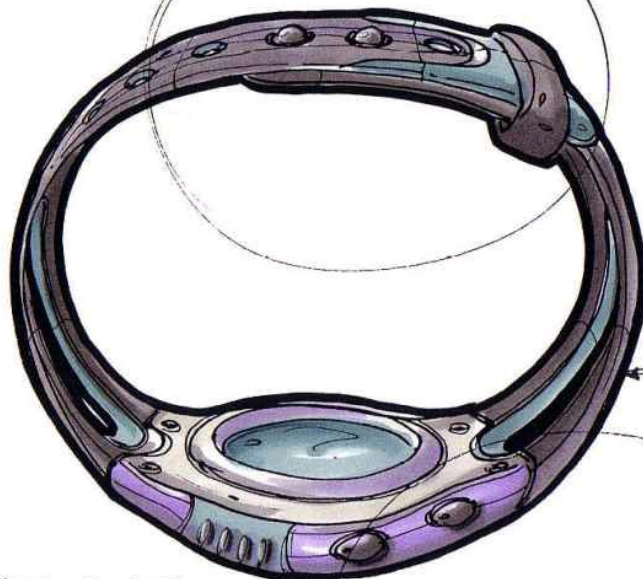

\* EASY TO PUT IT ON.



CO-MOLDED AIR HOLE

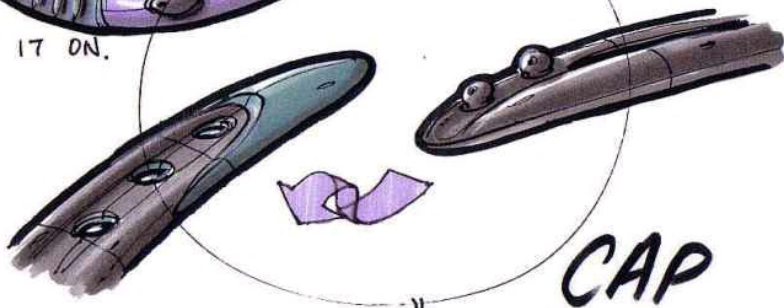

CAP

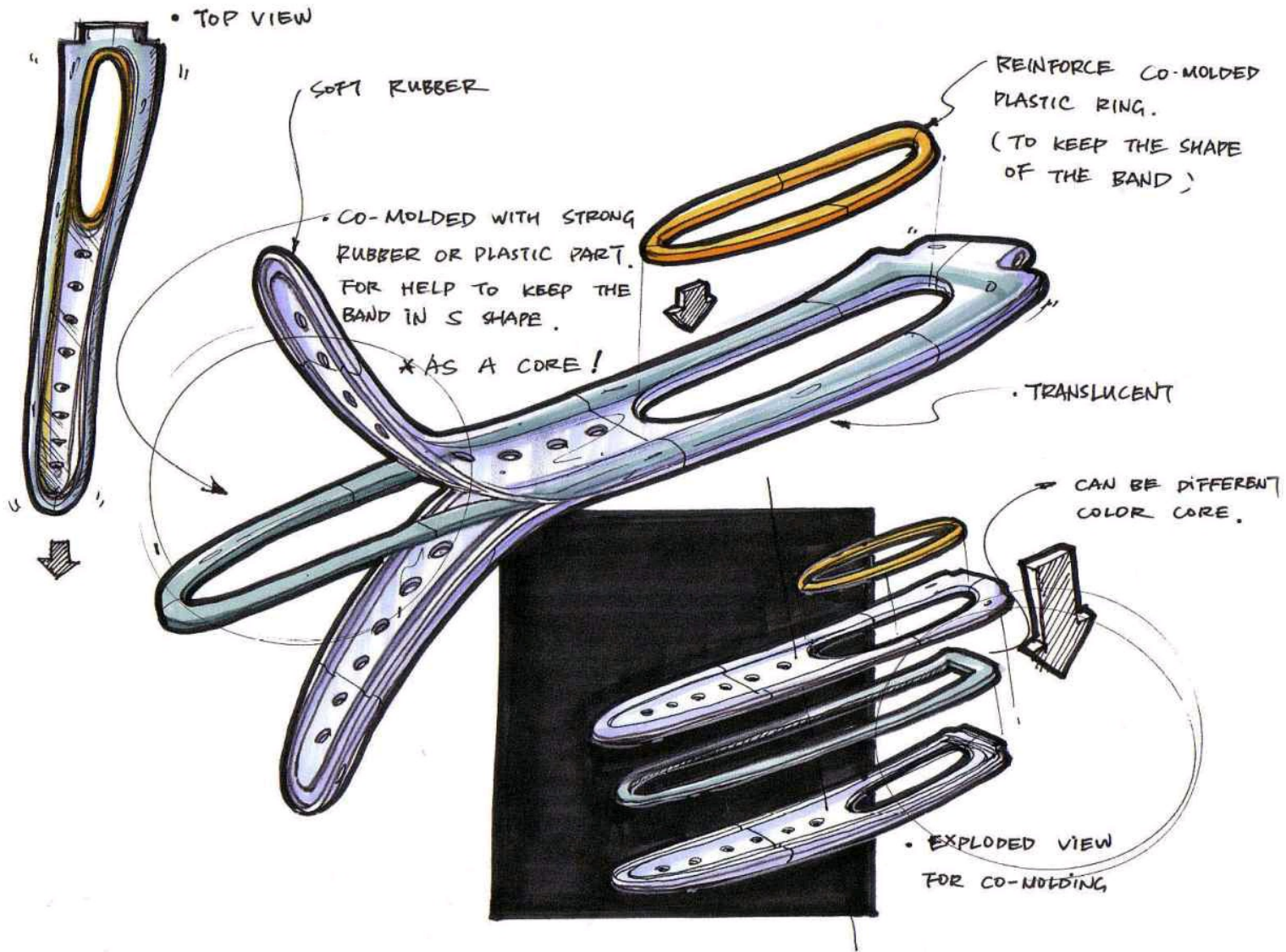

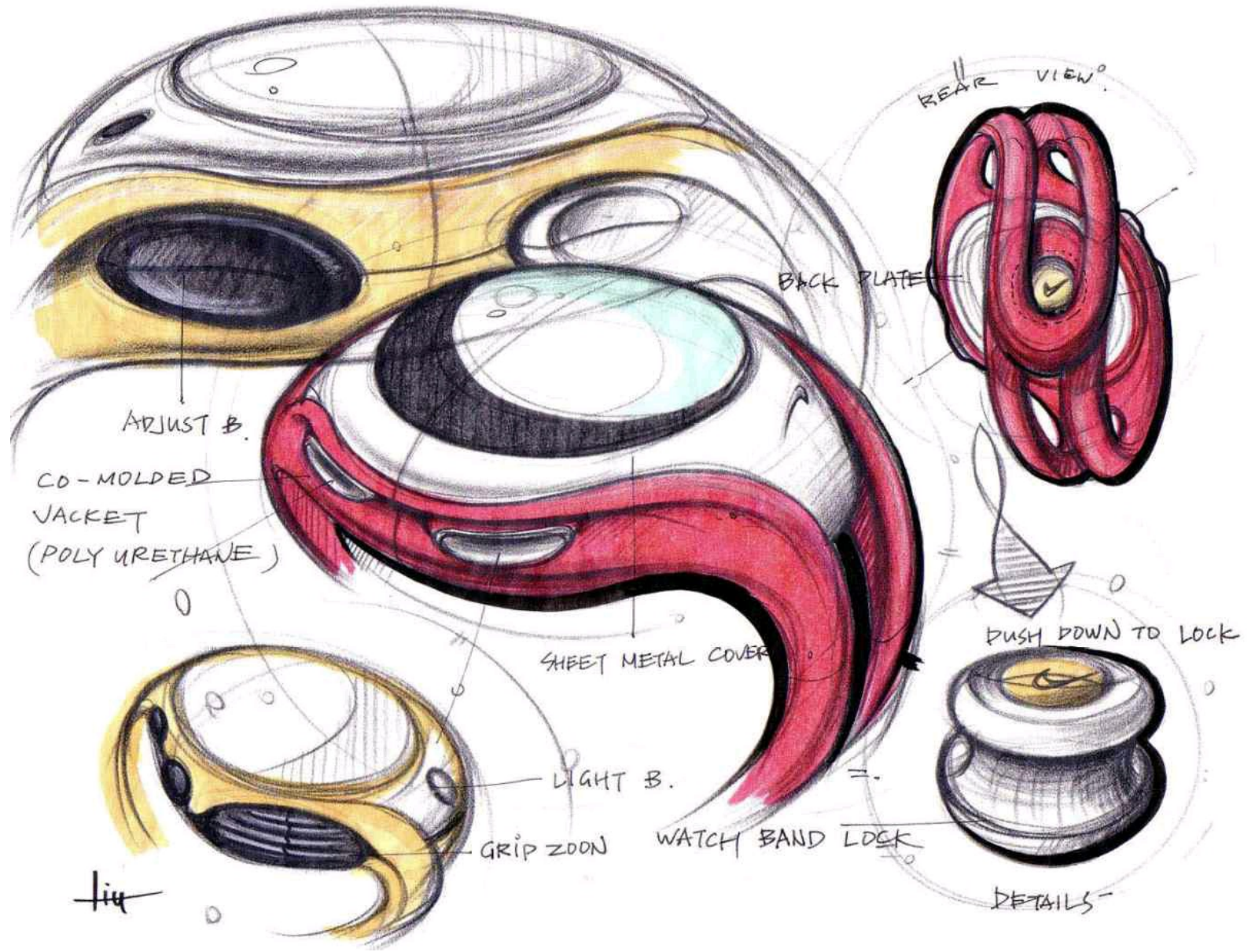

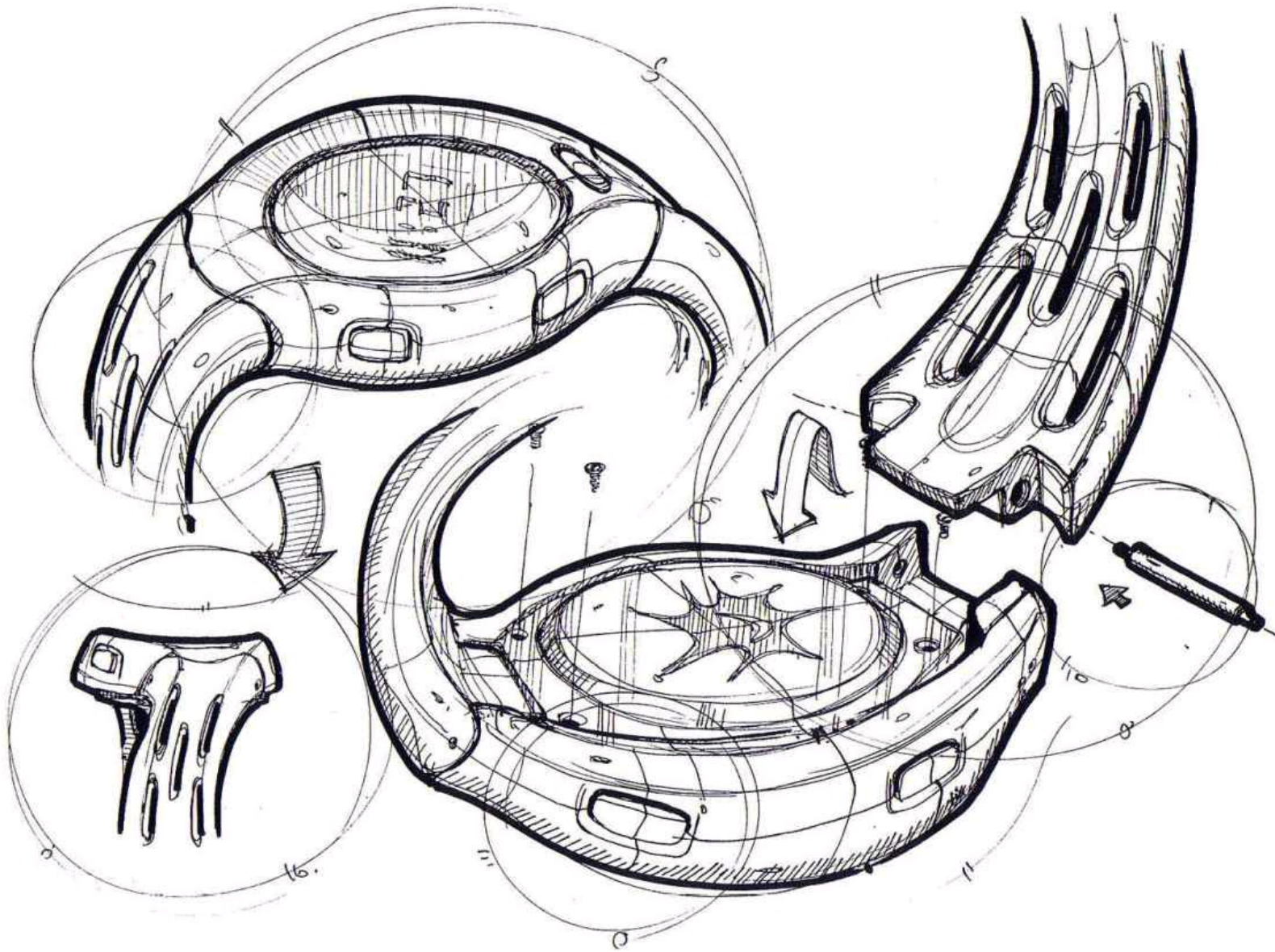

This page shows variable ideas of how the watch movement and the watch band to be assembly.

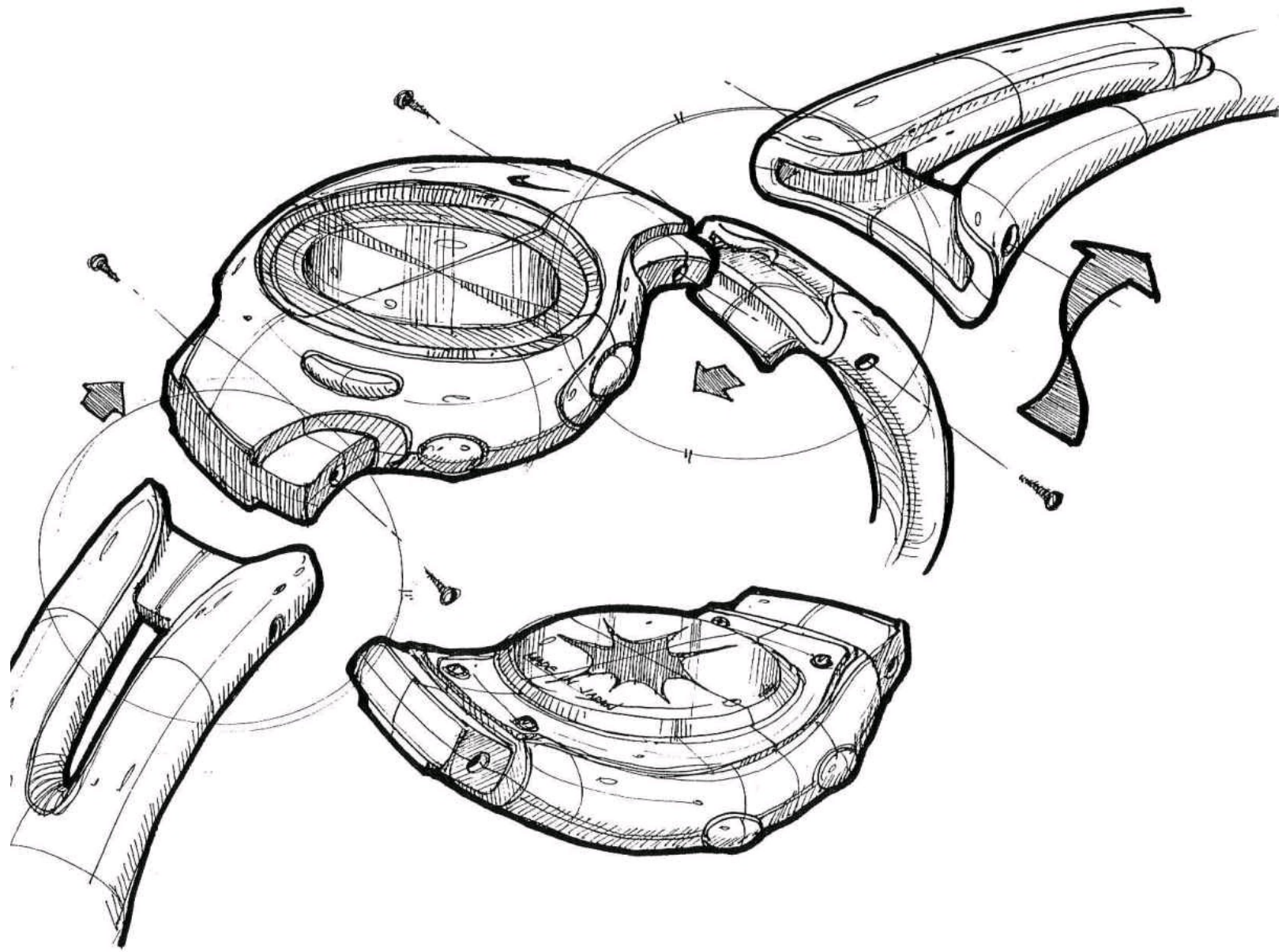

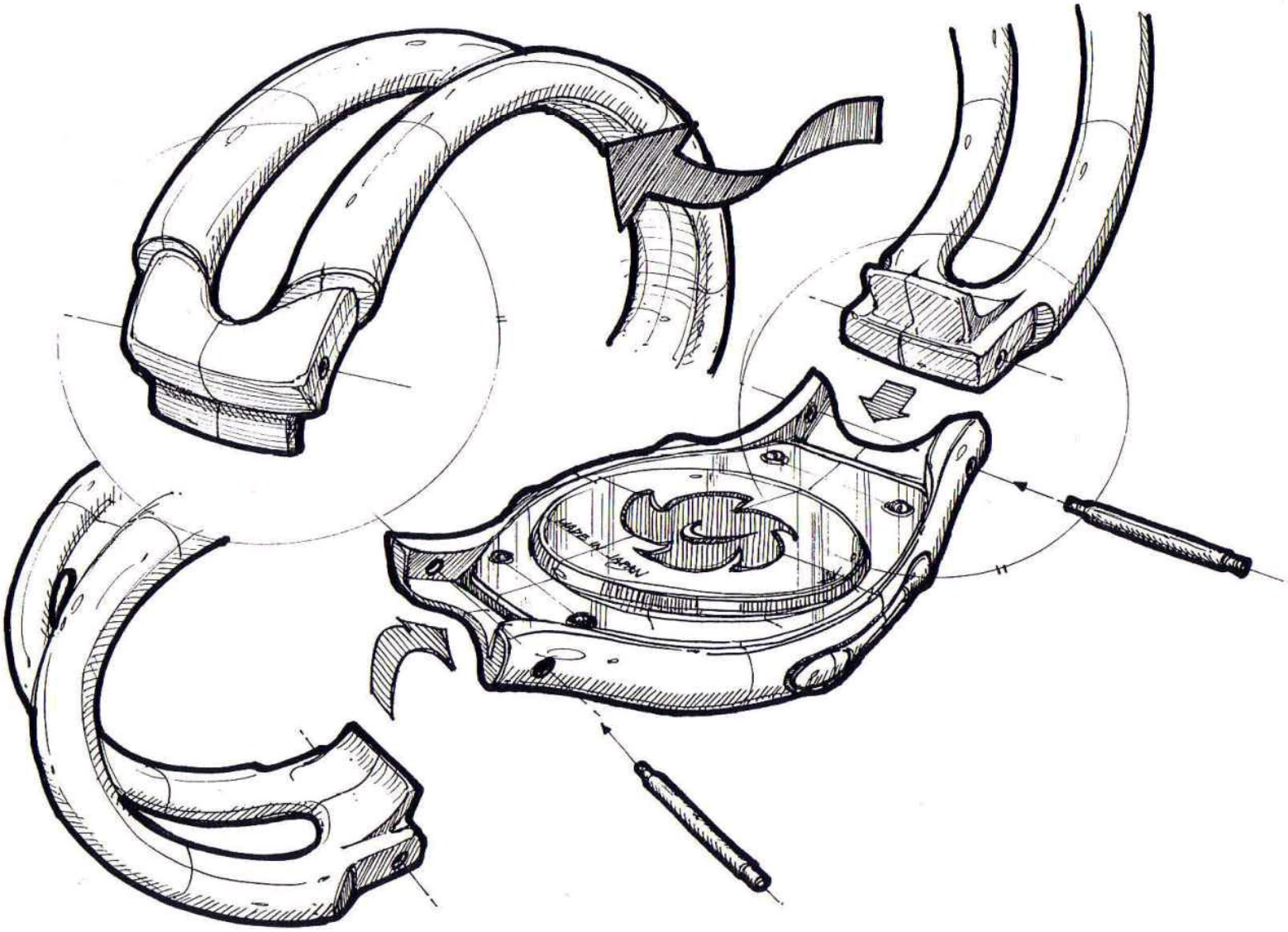



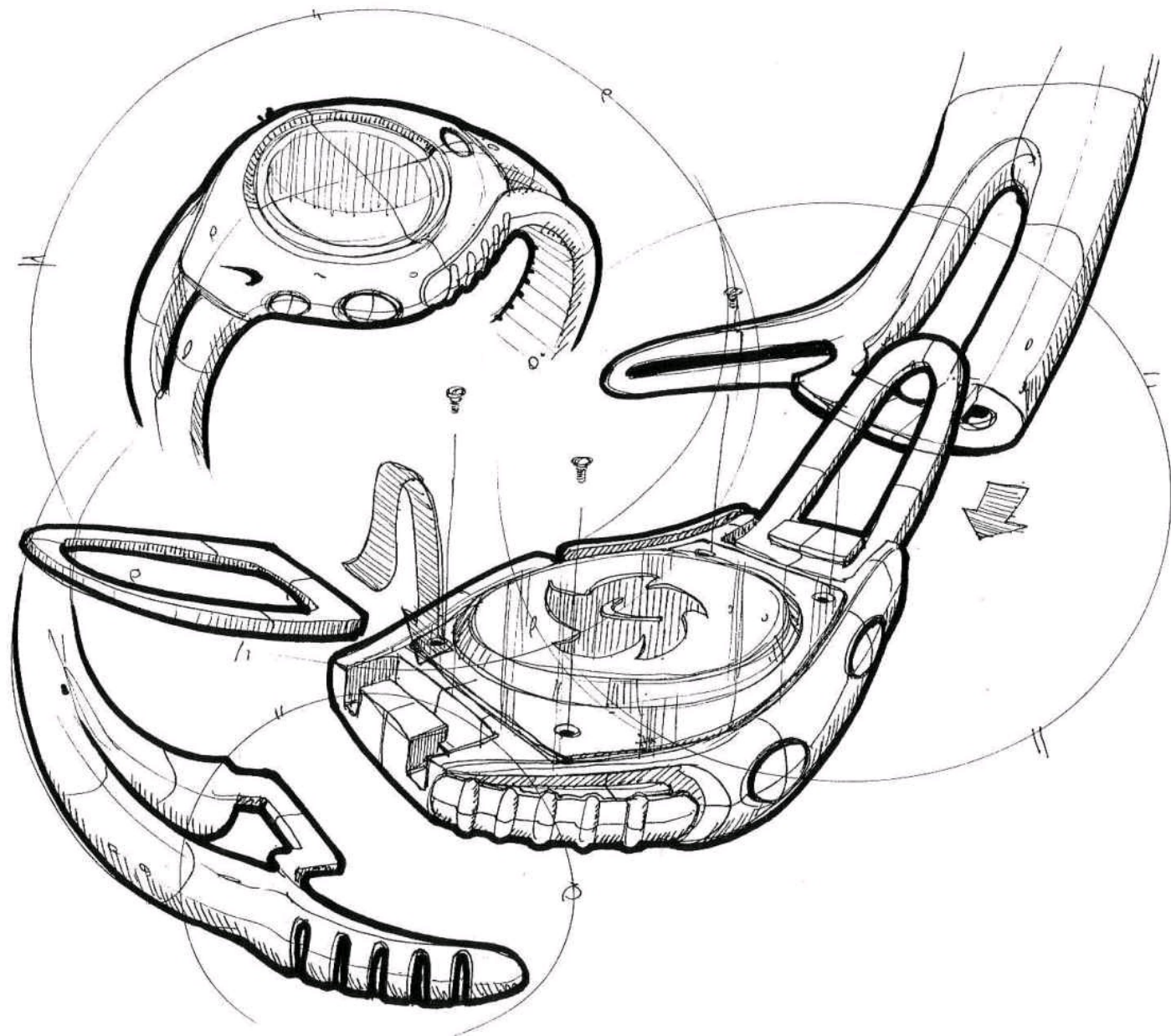

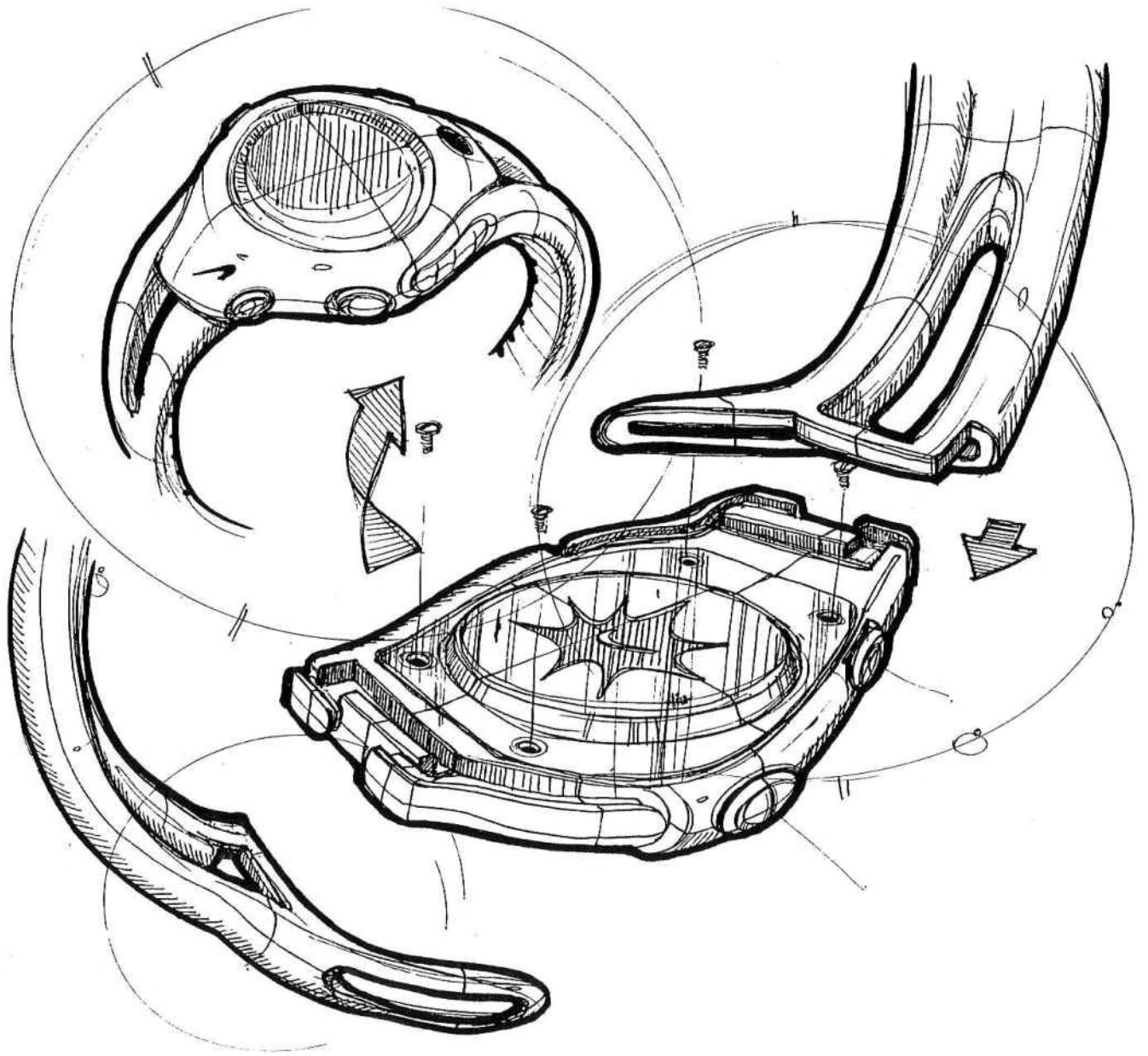

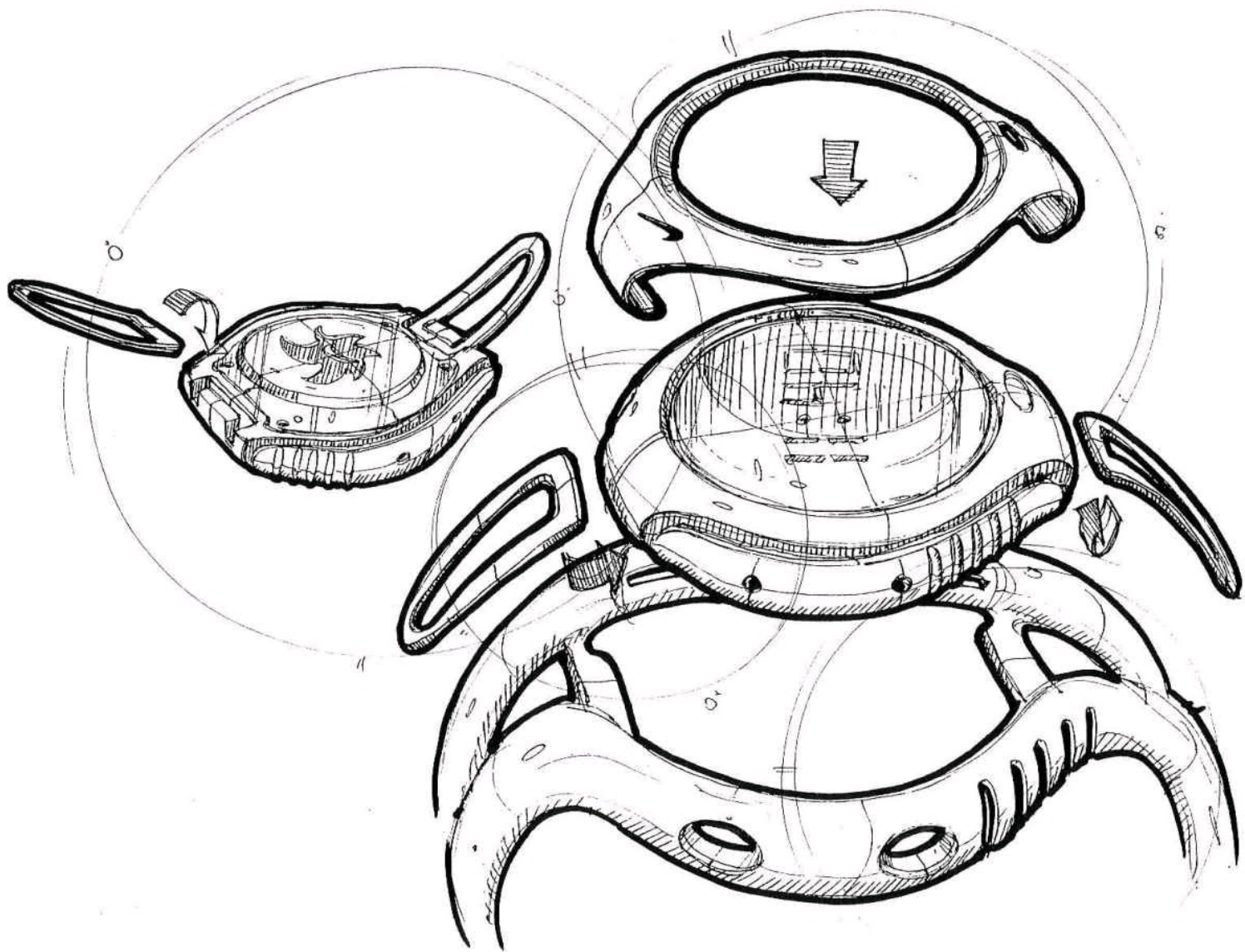

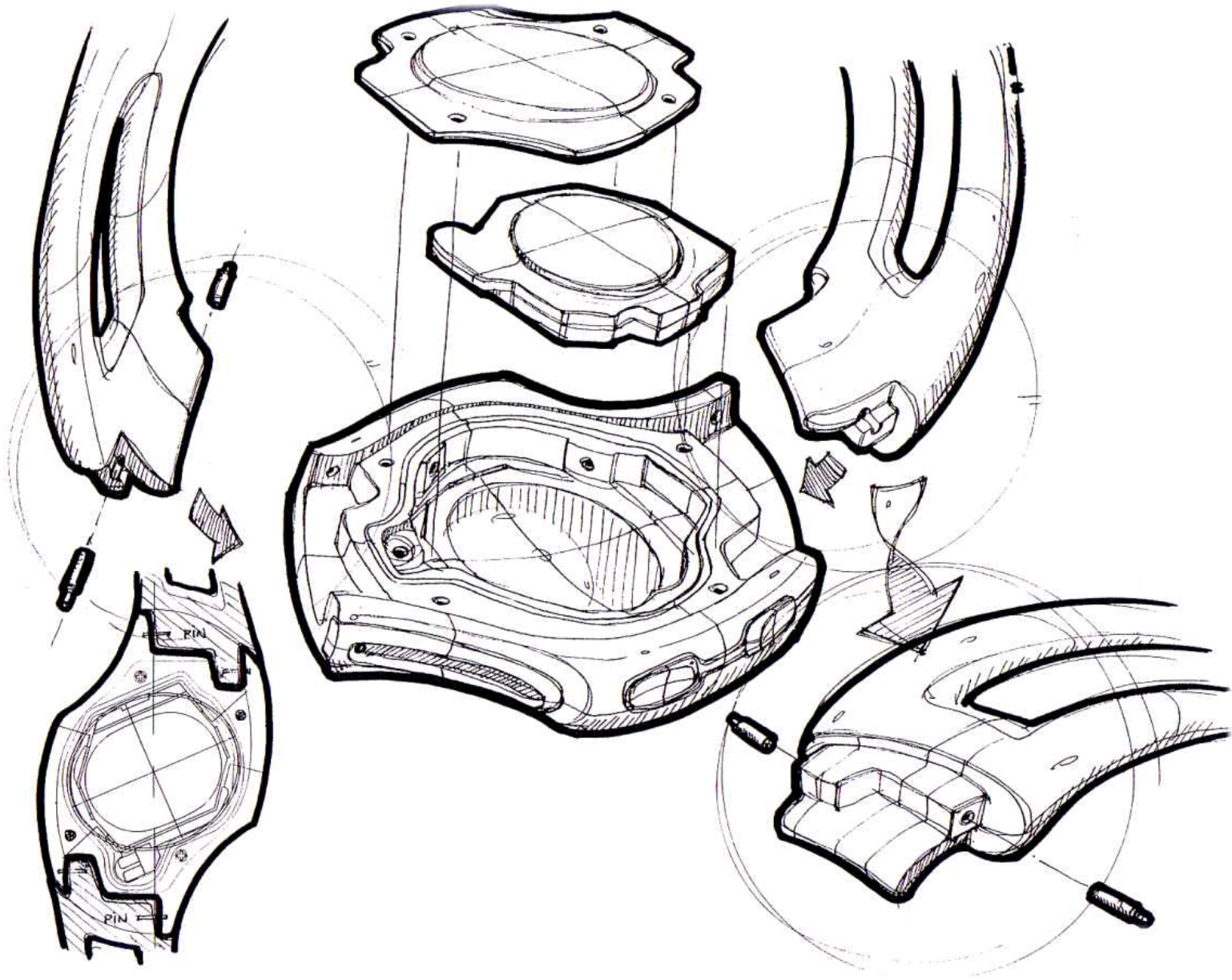

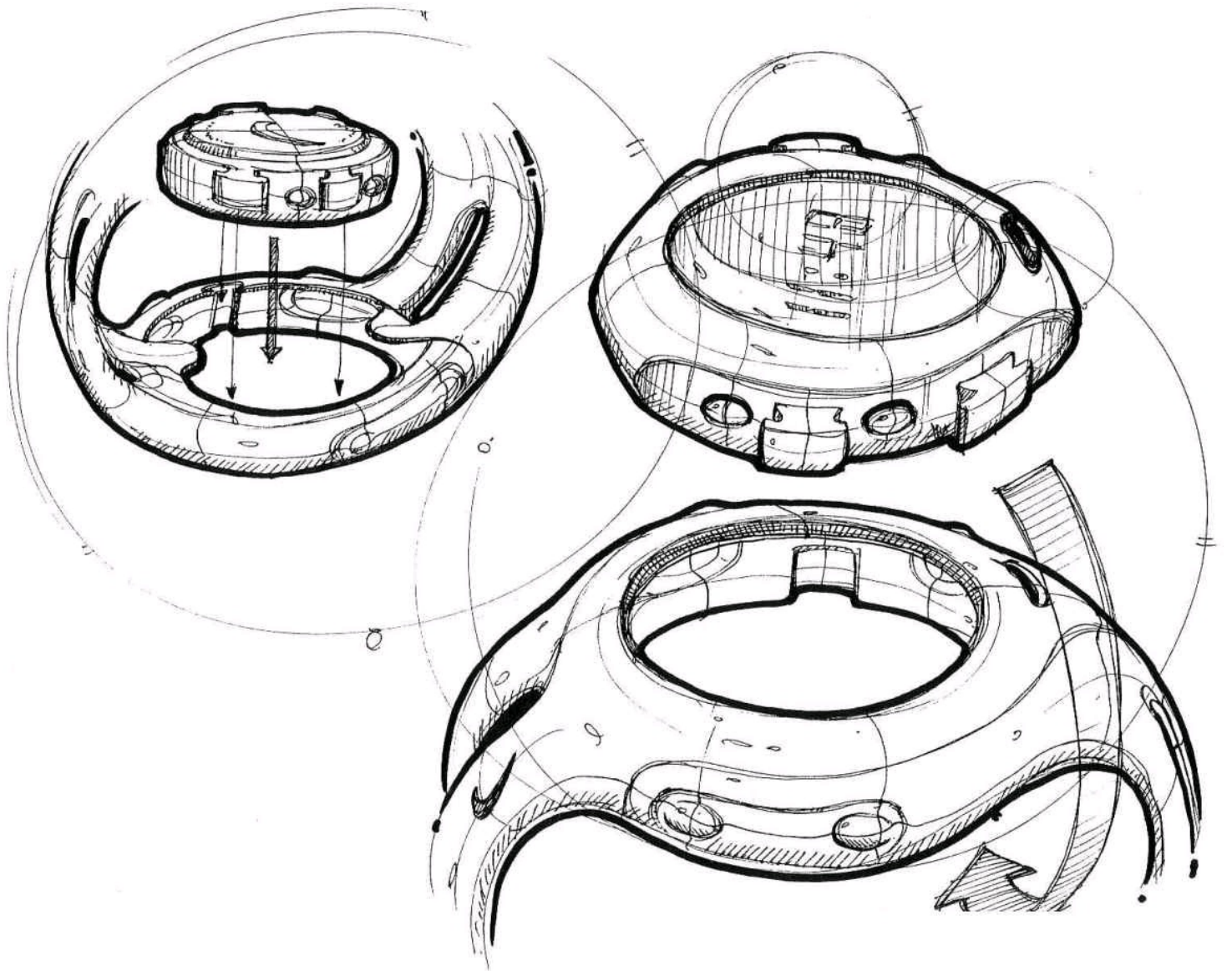

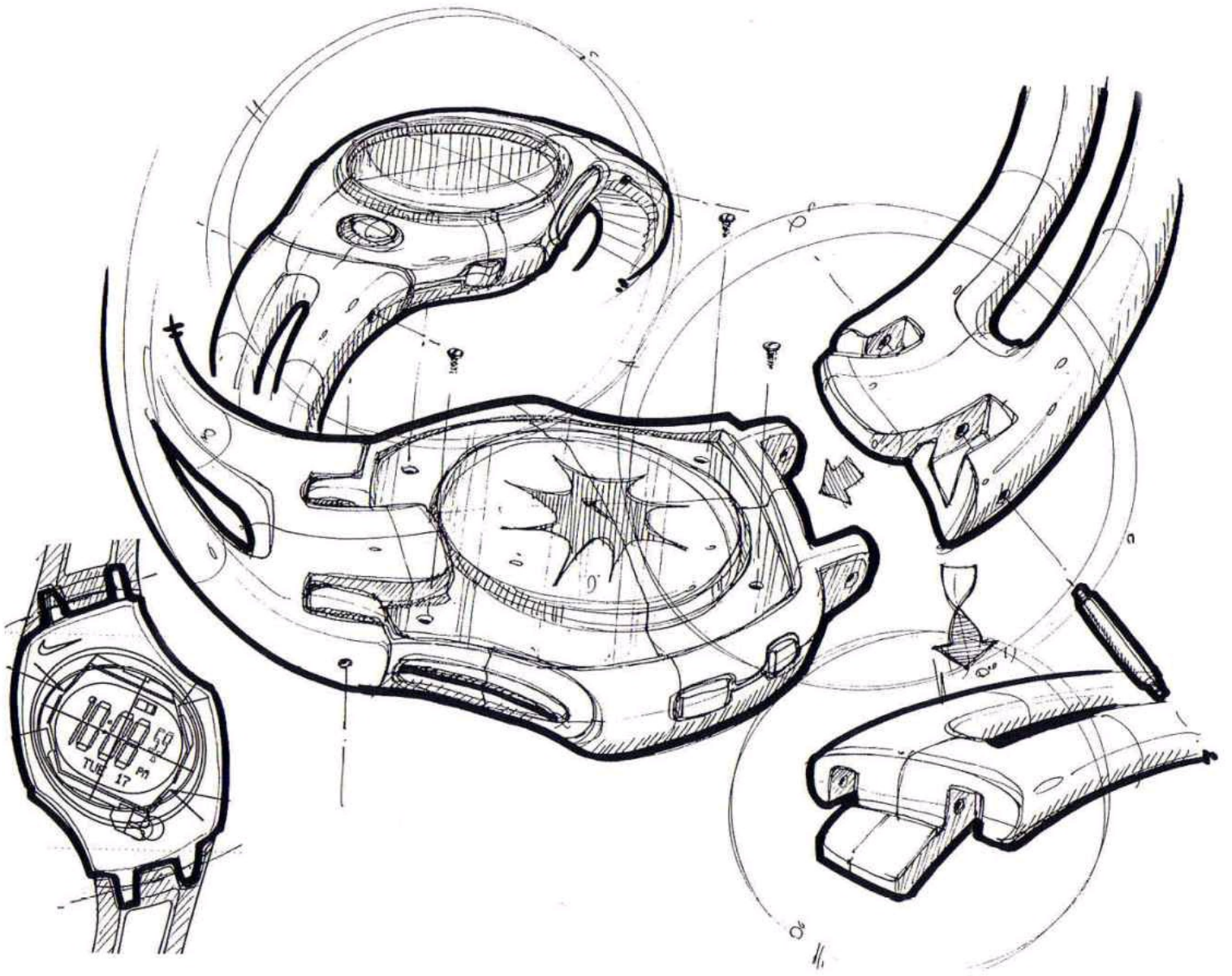



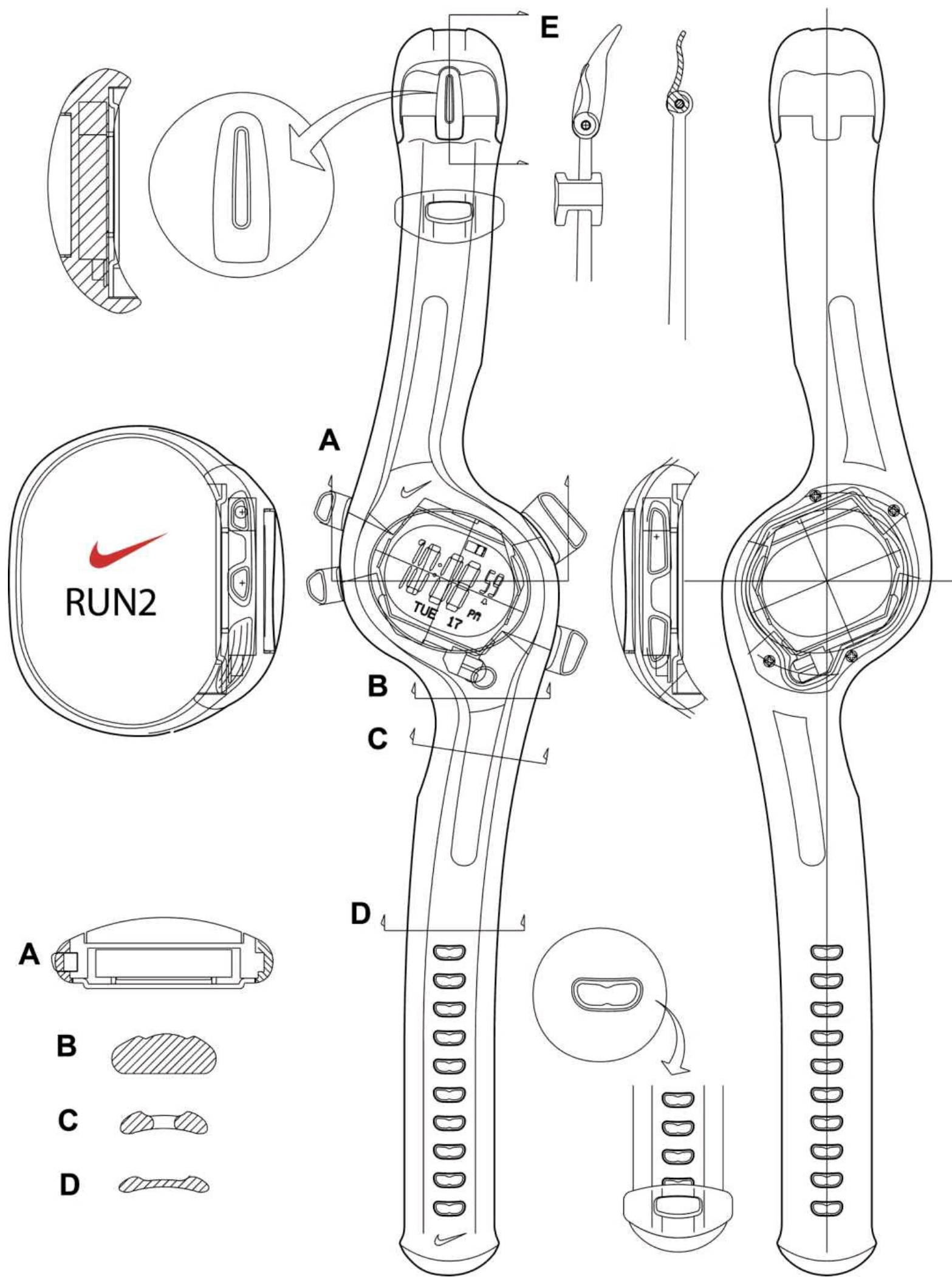







2D Illustrator rendering to show the basic part-break





Photoshop rendering



Alias model and rendering







## Case study VORTEX RING SHOOTER

Oddzon was a toy company. Its Swoosh product line was very popular and well known among American kids. To open a new line of toys for Vortex series, Astro designed various Vortex footballs and Tornado rubber ring shooter for them. I was assigned to work on a series of the ring shooters. In Toys R Us, Nerve toy guns occupied most of the shelf space. In order to compete with the Nerve toys, Oddzon had to come out a completely new product and yet it had to be so outstanding and unique to sweep the competitors. Function Engineering was hired to create a unique launch system which could maximize shooting range for fun, yet minimize propulsion and impact for safety. Function Engineering consulted with ballistics experts to achieve the distance / accuracy characteristics.

To engineering by trial and error, they finally came out the ring launch mechanism powered by a single spring. The shooter launched aerodynamic soft plastic rings that flew in a spinning motion to maximize flying distance and accuracy. The unit met all consumer safety requirements and then spawned the complete line of toys based on the same mechanism. Working with creative Function engineers, I realized how critical to be supported by great engineering teams if designers wished for a breakthrough product. Comparing with developing the complex internal mechanism, ID seemed a lot easier and straight forward. Once I tried out the shooting mechanism, I suggested a less childish design for the series of product because I felt this toy would attract older kids due to the launcher's magnificent shooting distance and accuracy.

Together with Function Engineering, Kyle and I also proposed a modular inner housing to enclose the shooting mechanism for future products' cost reduction. In toy design, cost, safety and durability were three major factors to always keep in mind. In cost, traditional toy market were extremely compatible, so I avoided complicated assembly process, reduced parts and chose minimum paint finish. In safety and ergonomic, I got rid of every sharp corners could possibly harm little kids then I designed the big T shape loader for easy spring loading. In durability, kids abused toys, so I tried to have less moving parts and weak joints in case the toy dropped and shattered in pieces. Although there were so many restraints from designing a toy, I, as a junior designer, had learned to design a project from a business point of view than just a For Vortex ring shooters, I designed a total four different shooters to cover

broader markets. They were pretty fun projects to work on. I was quite pleased to see my designs were in stores neck and neck competing with the Nerve toys during the white Christmas season.

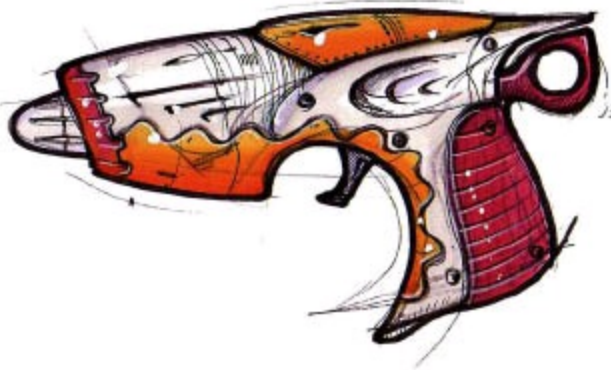
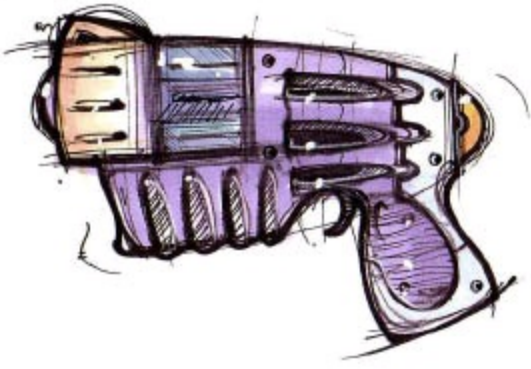

I liked the proportion and the friendly look

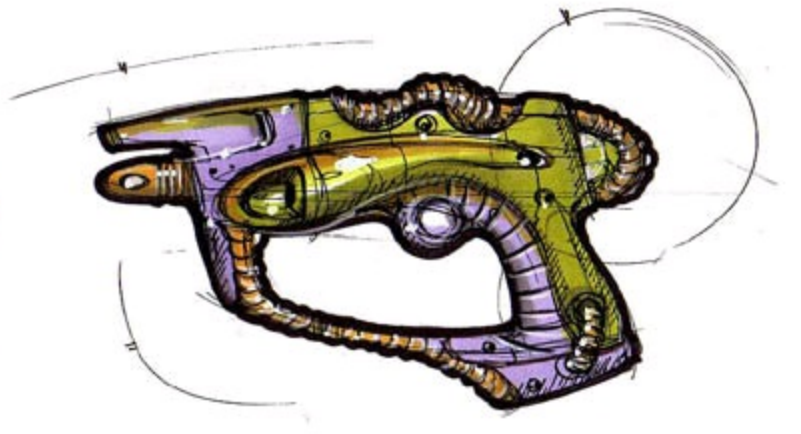
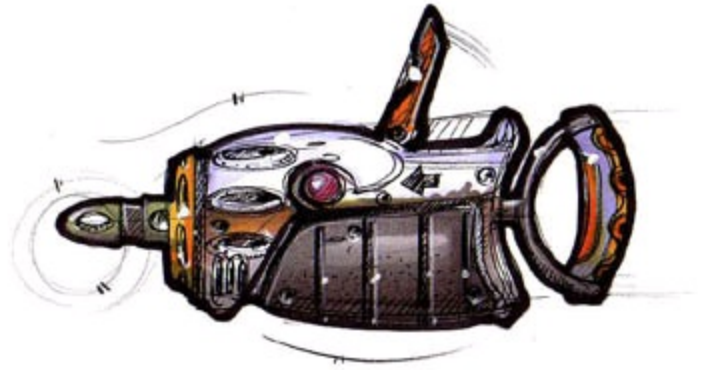

This one got picked as a reference for final design. This approach was picked as one of the final direction. Different way to think about a toy ring launcher, it looked like a big needle.

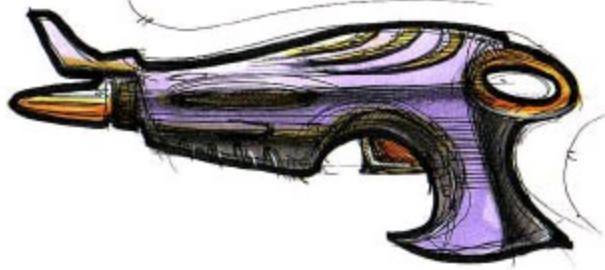
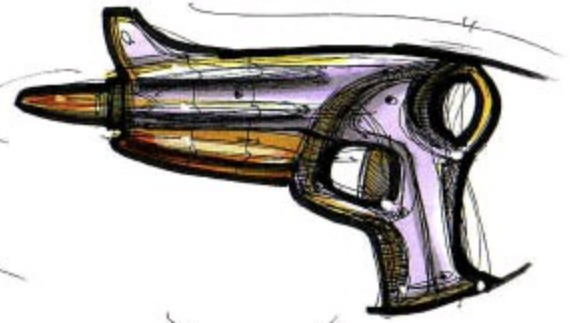
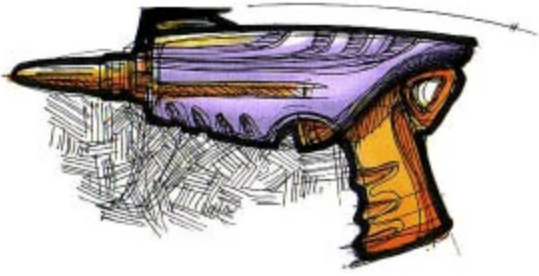

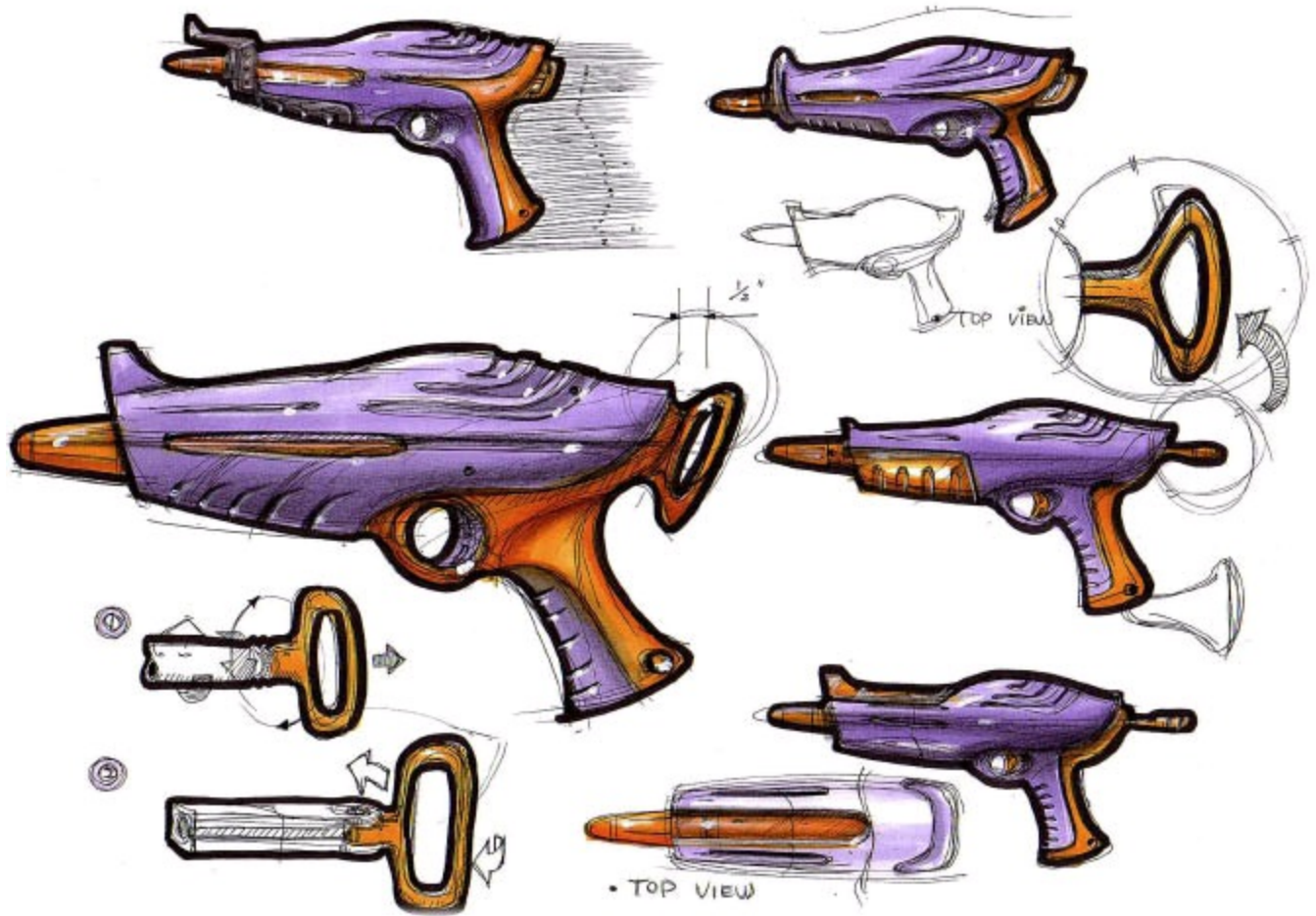

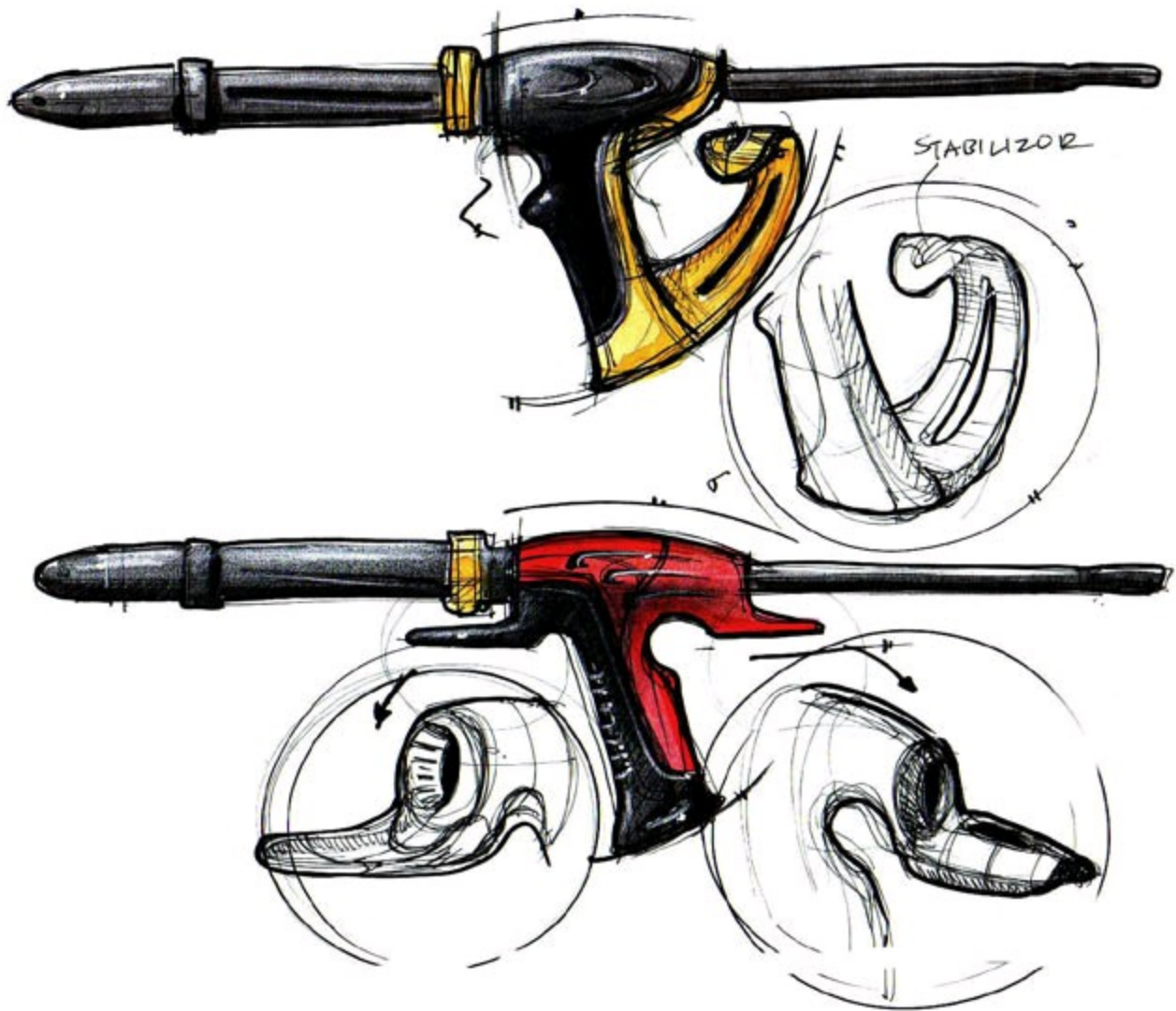

Mini shooter designs. After designing the long shooter and pistol shooter, the client wanted to make two mini shooters to complete this new product line. This duck tail design would save strength while doing the pulling and loading action. Magazine to store ammo (rubber rings).  
action. Magazine to store ammo (rubber rings).

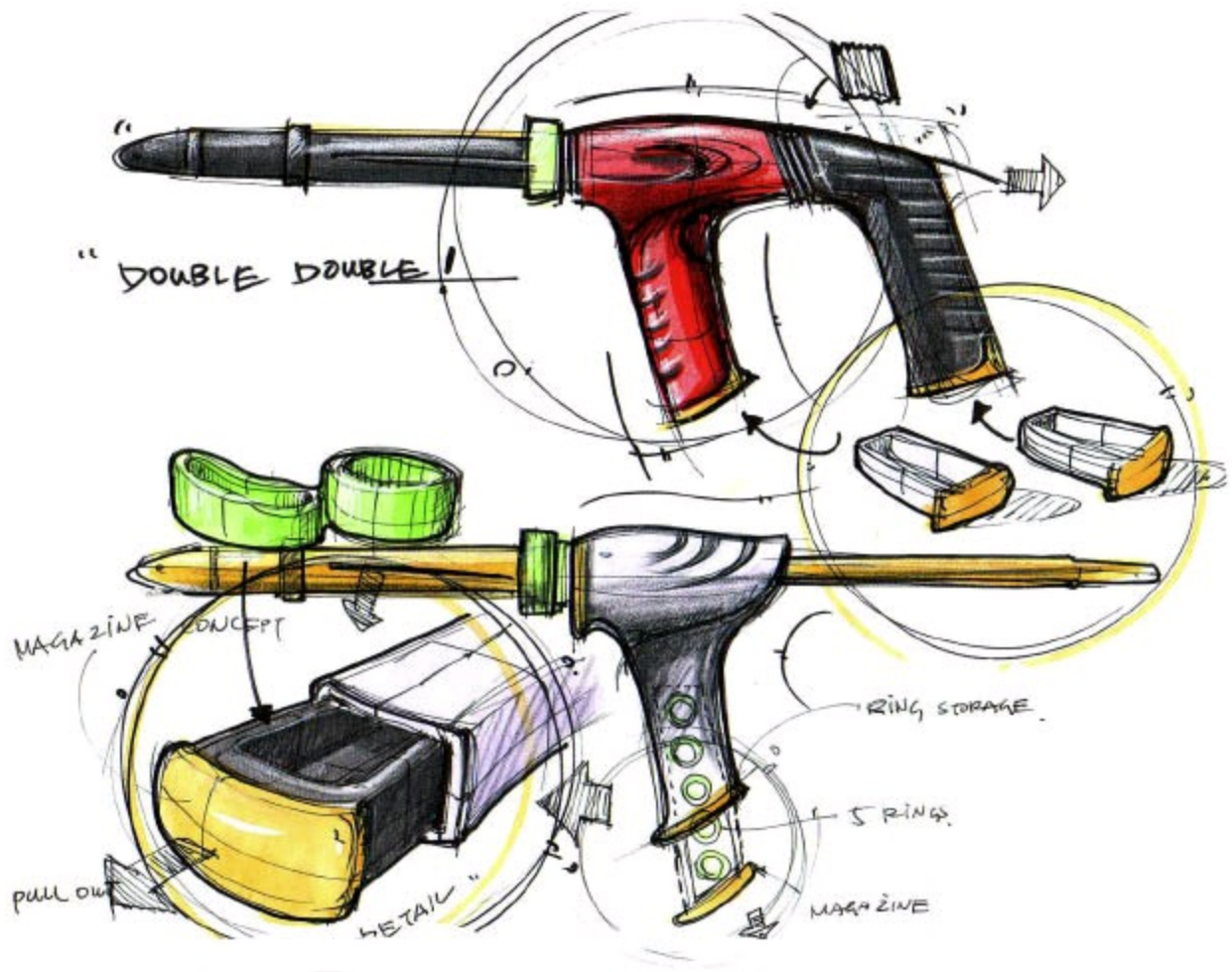



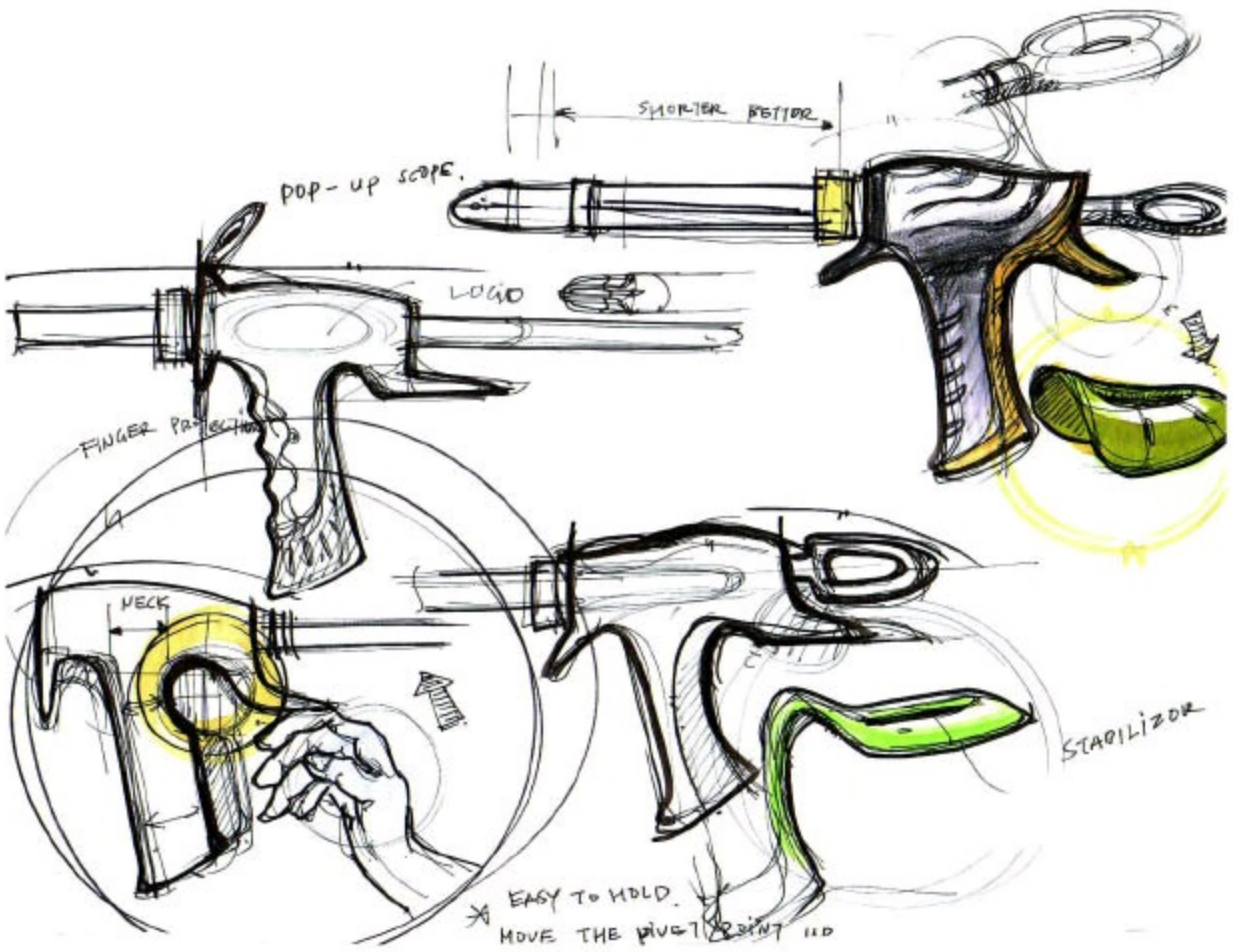

How the stabilizer worked.

SPOTS FOR RING STORAGE

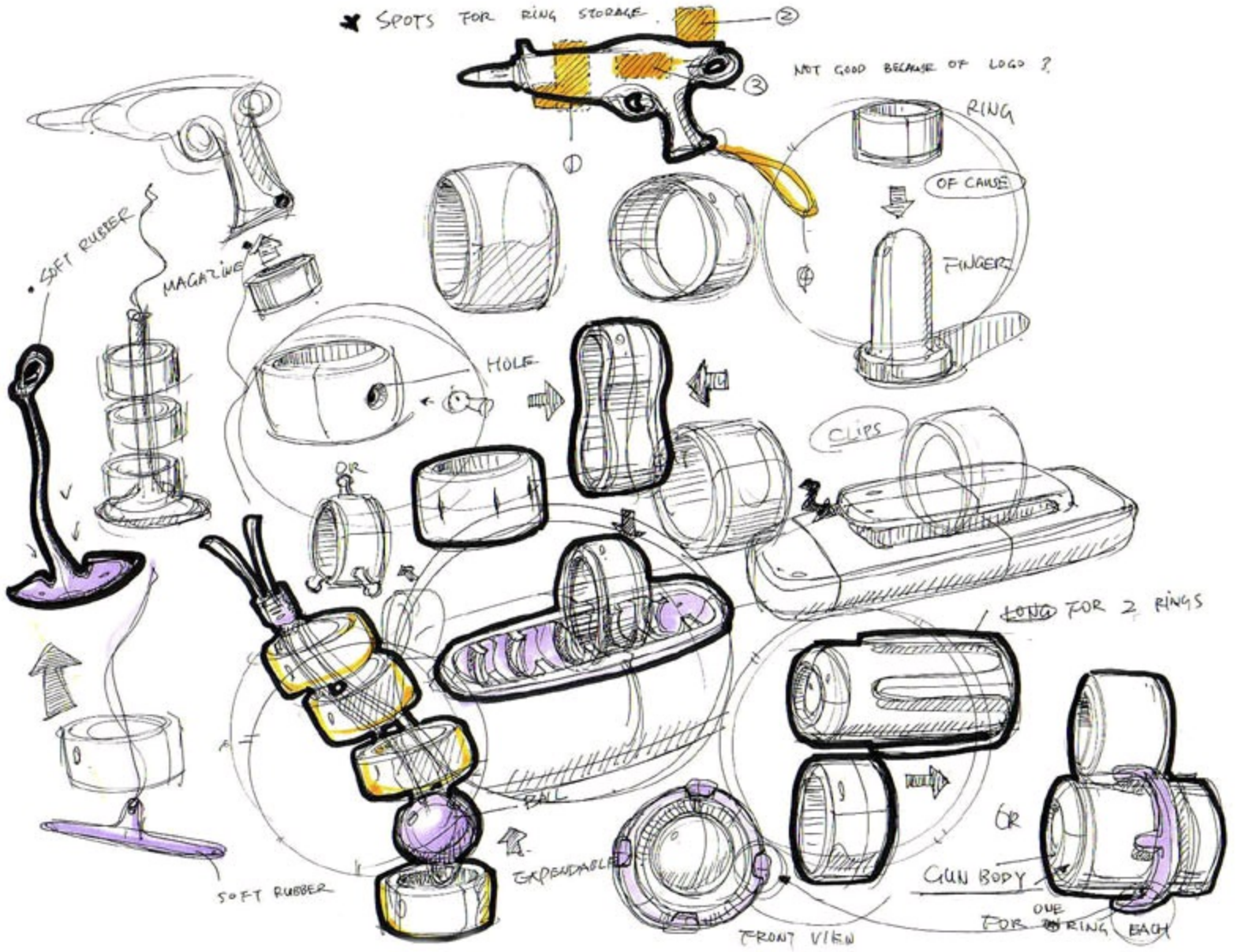

Exploring the ways to carry the rubber rings.

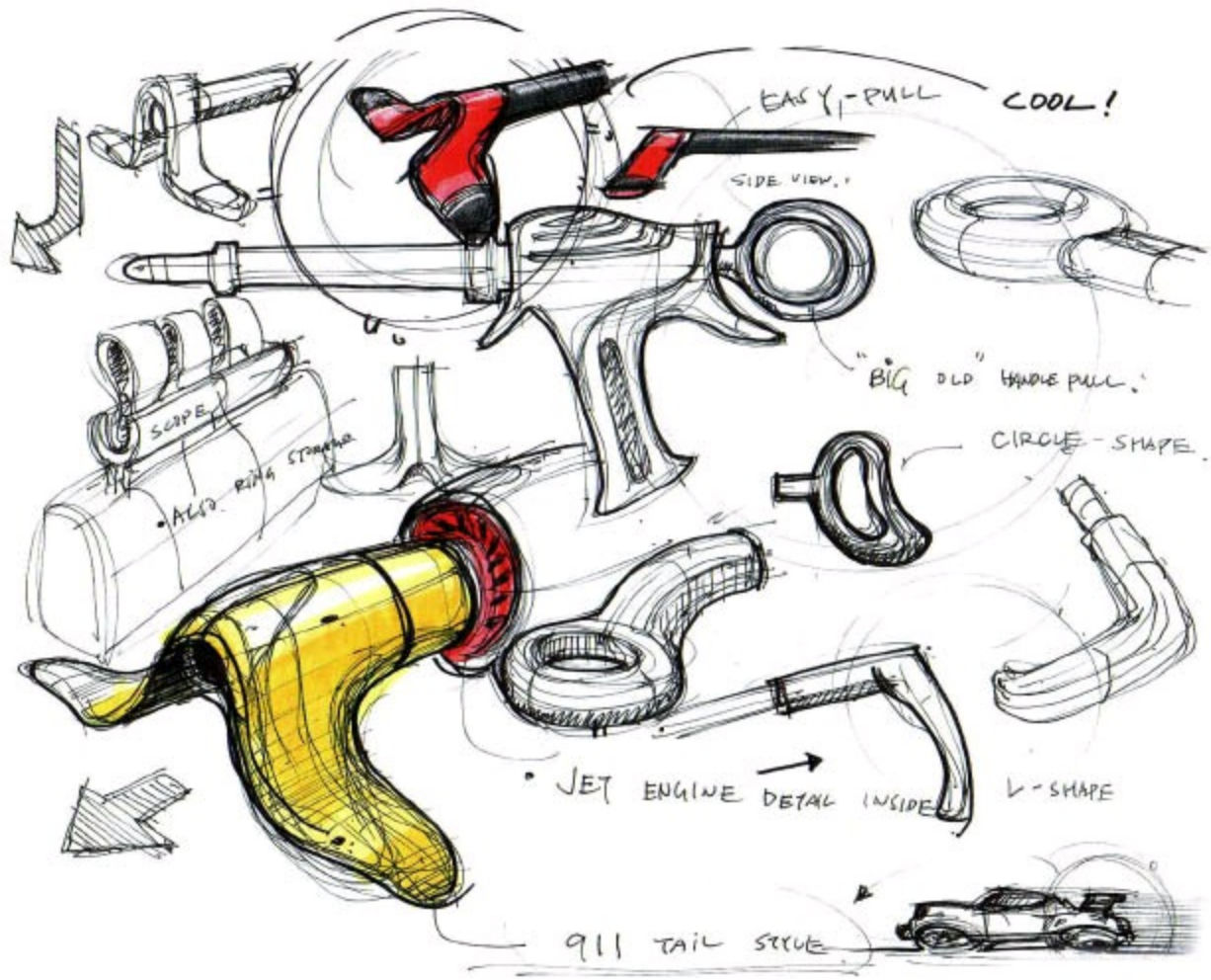

More concepts for the easy trigger design.

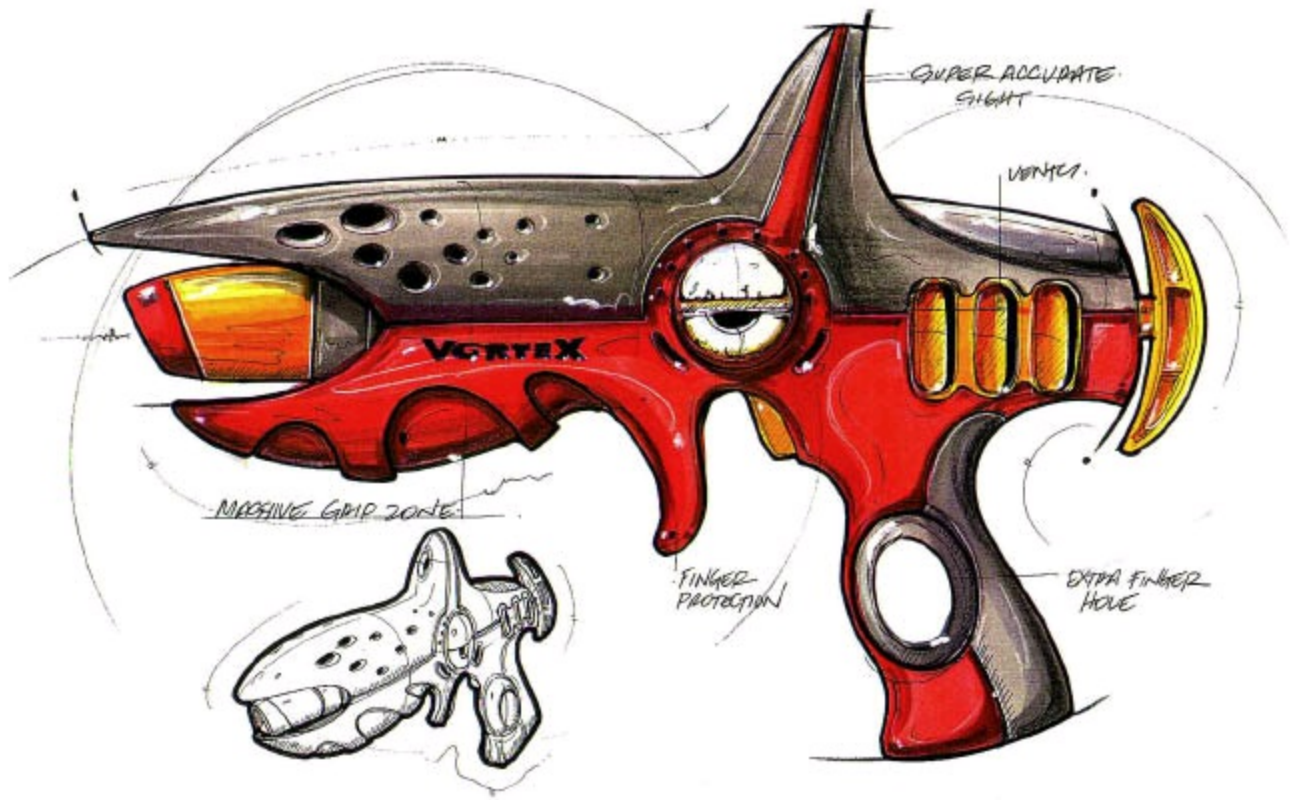

Cool factor: Open the jaw to load rubber rings.

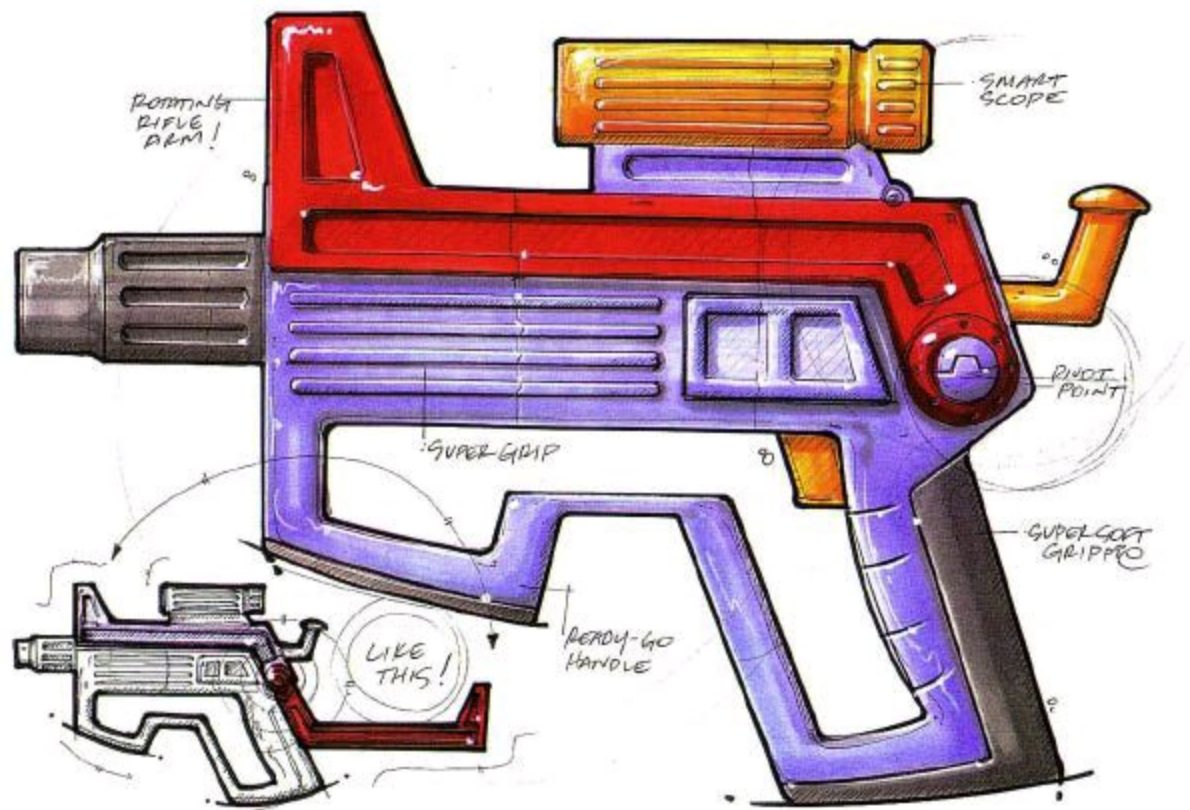

Cool factor: rotate the sight to become the shoulder rest.

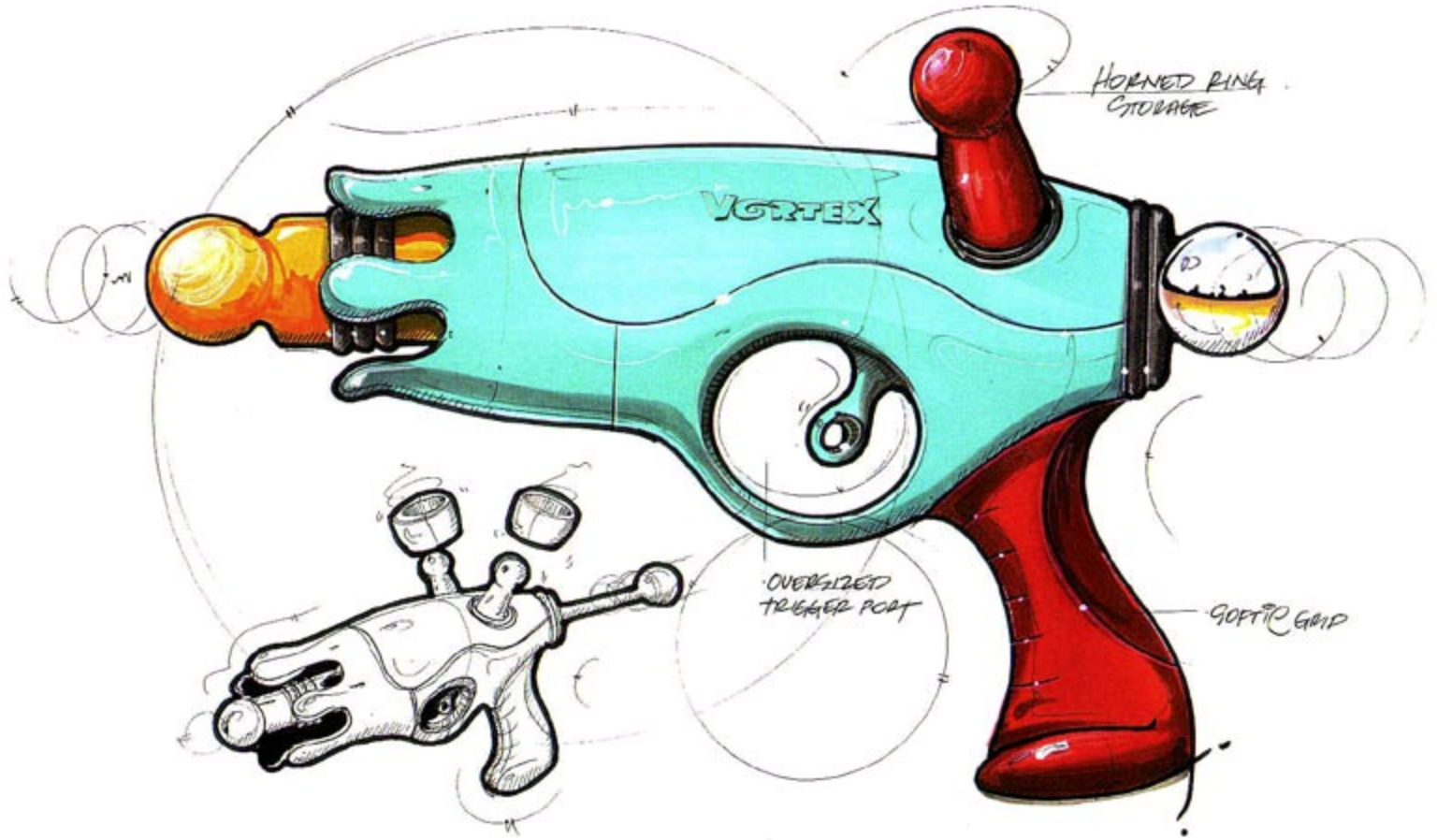

Fun and friendly design. Rubber ring storage.

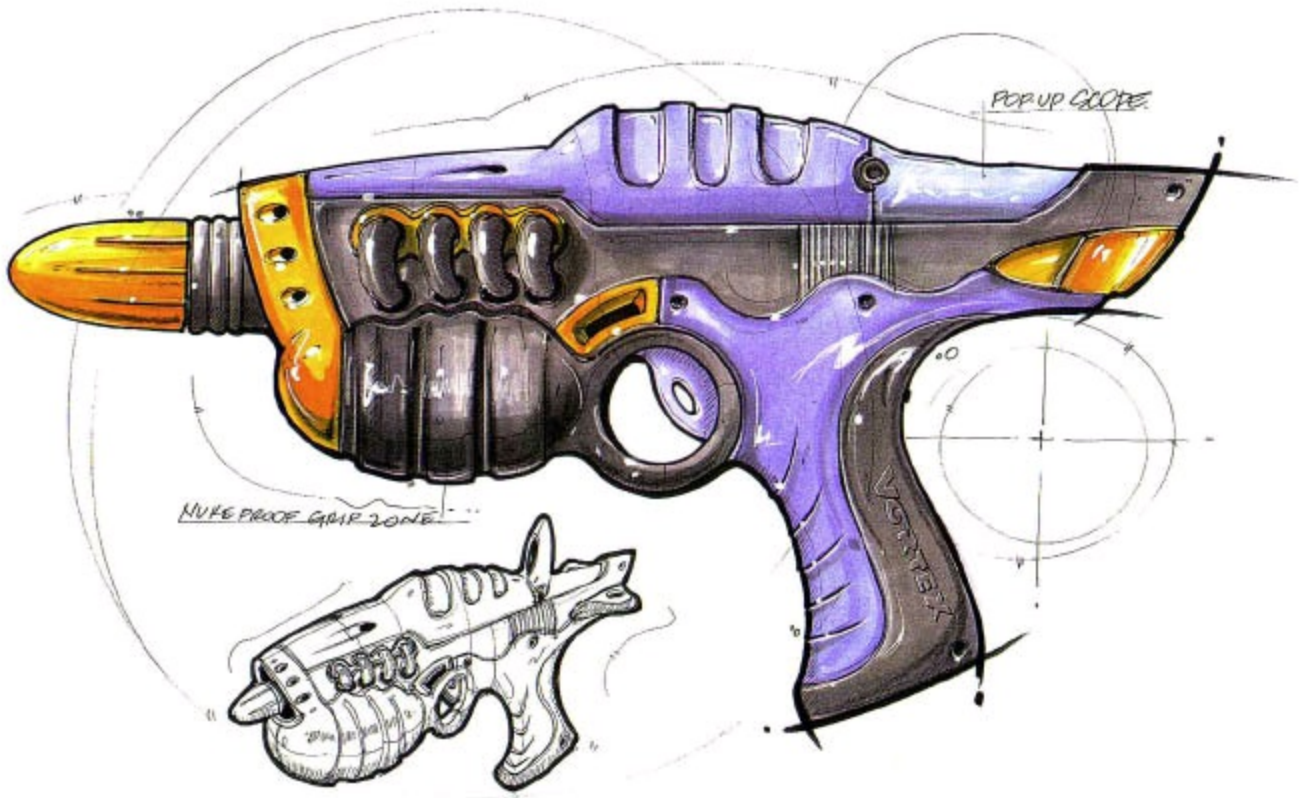

Engine detail gave the powerful look and feel.

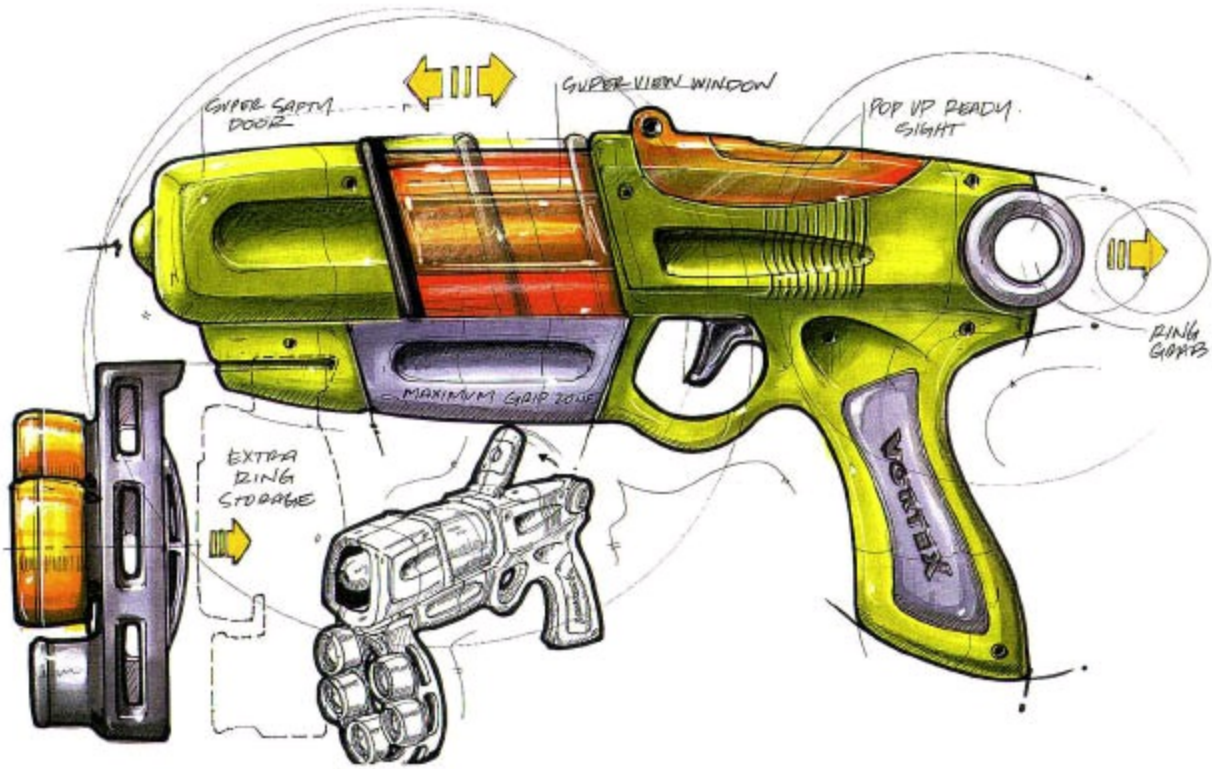

Removable ring storage design. Integrated spring-loading pull.



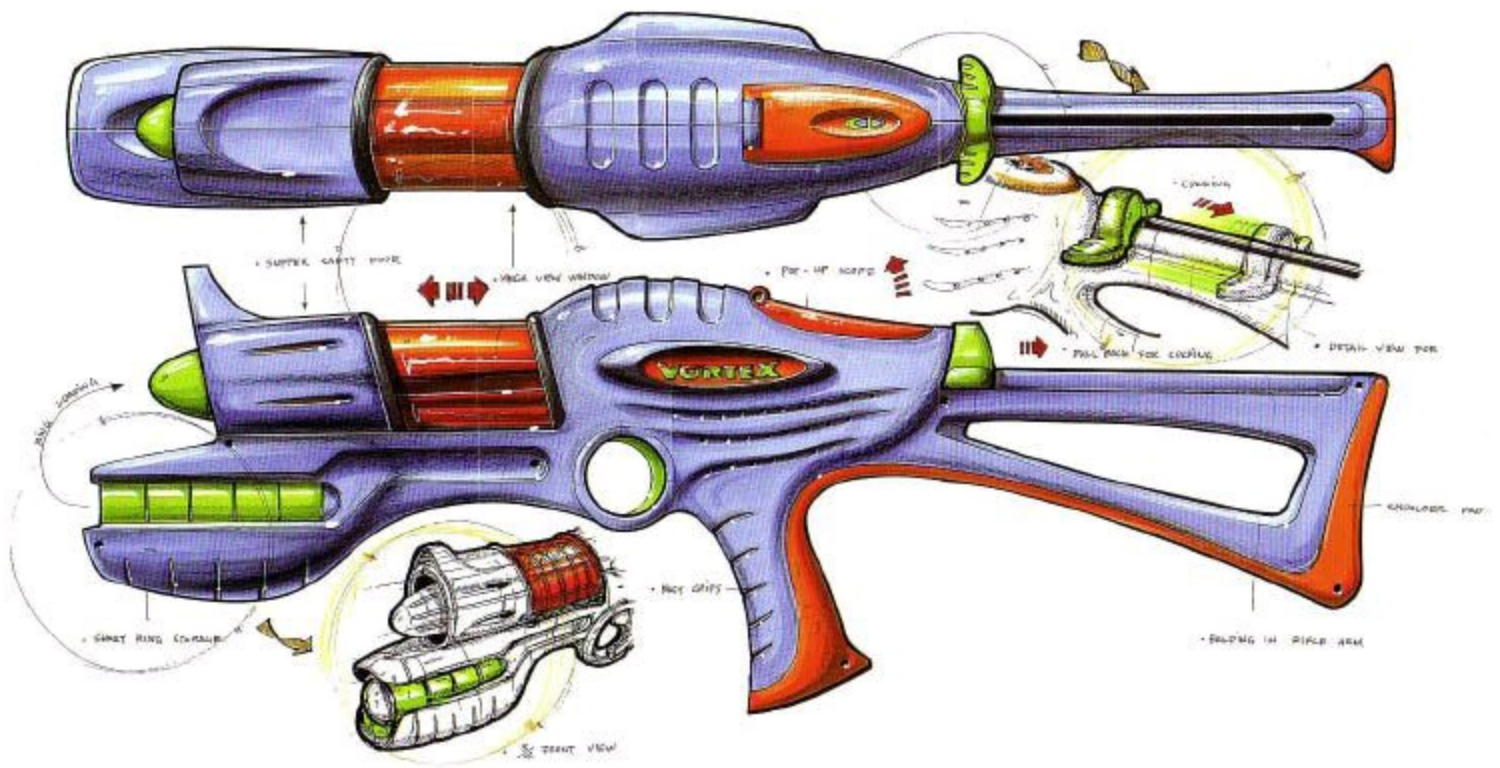

Final design for the rifle type shooter.

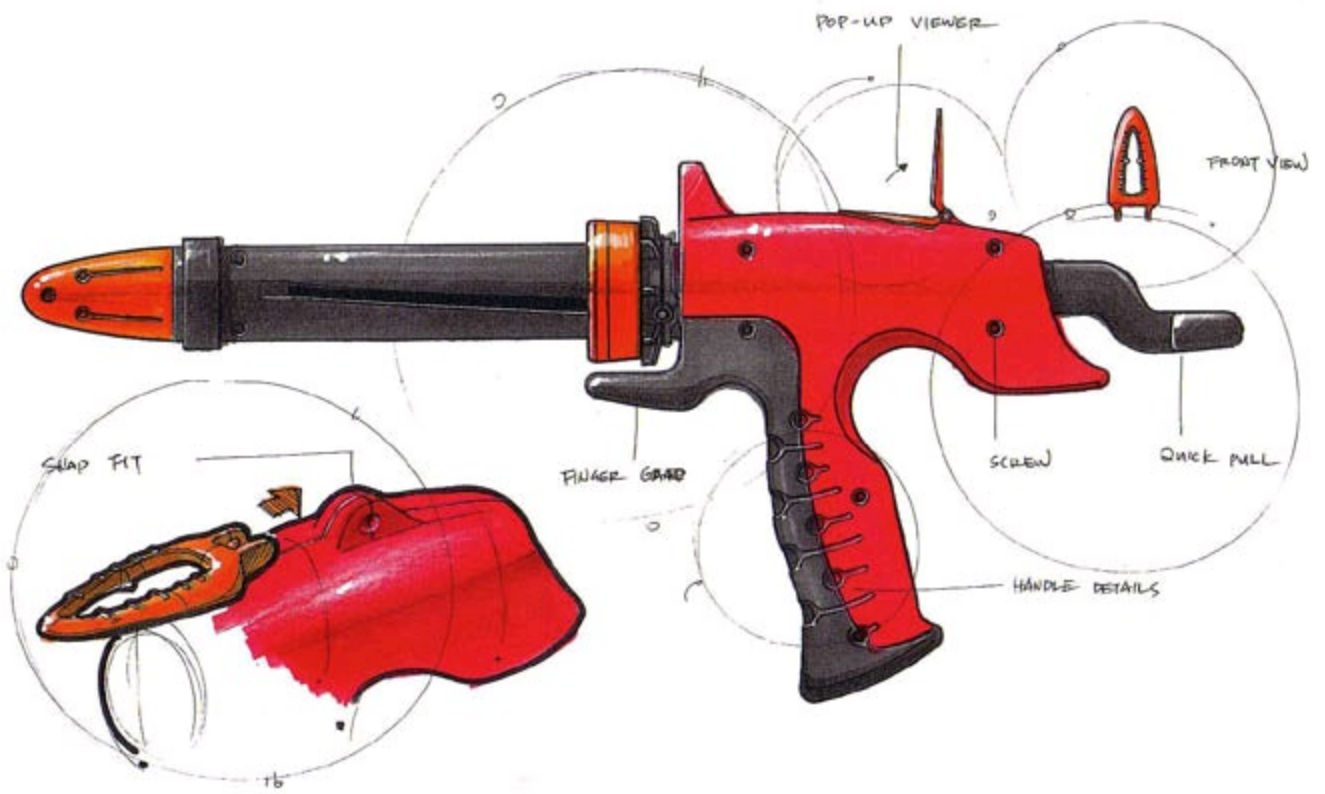

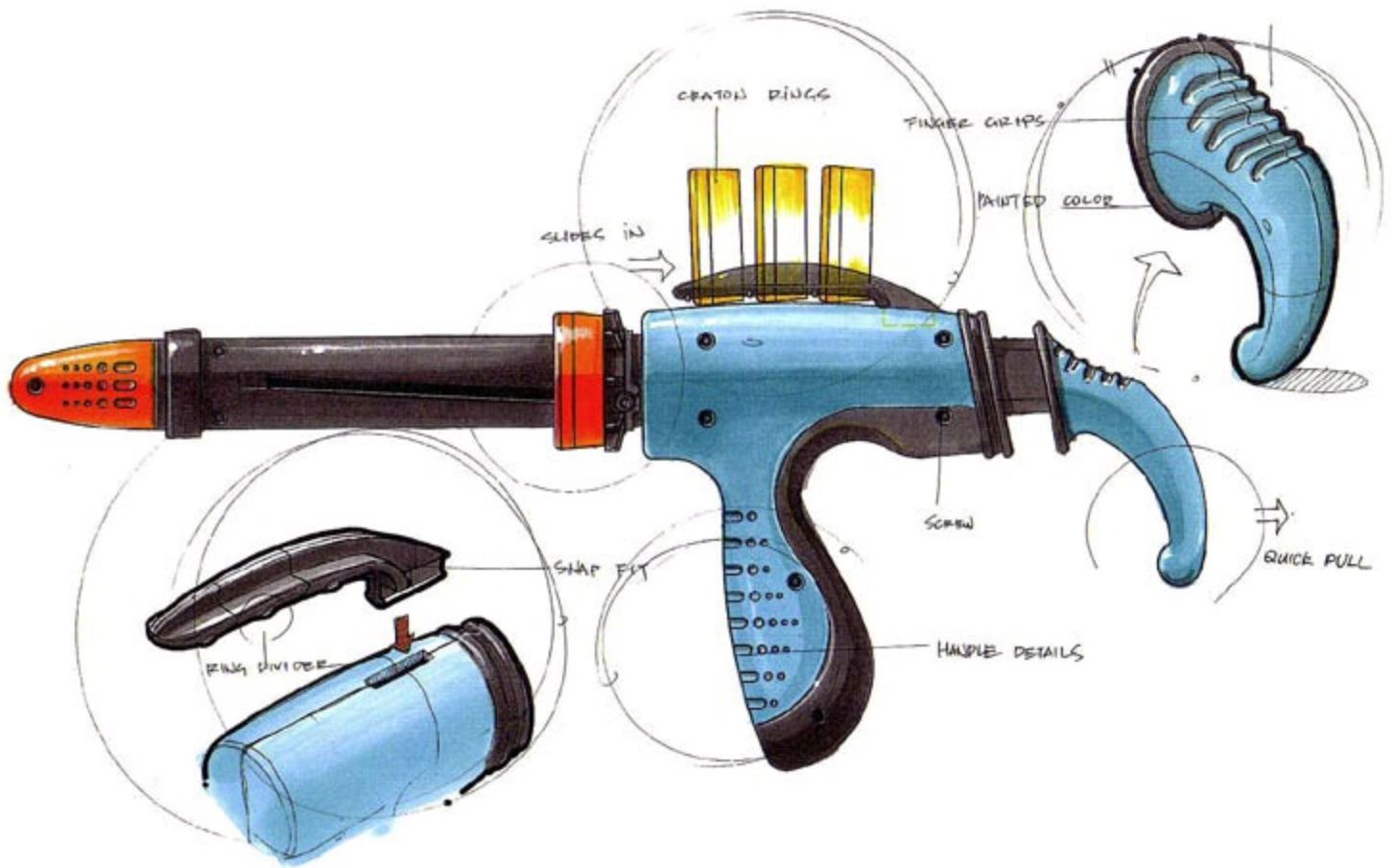

Two final designs for the mini ring shooter. Two designs shared the same internal components.

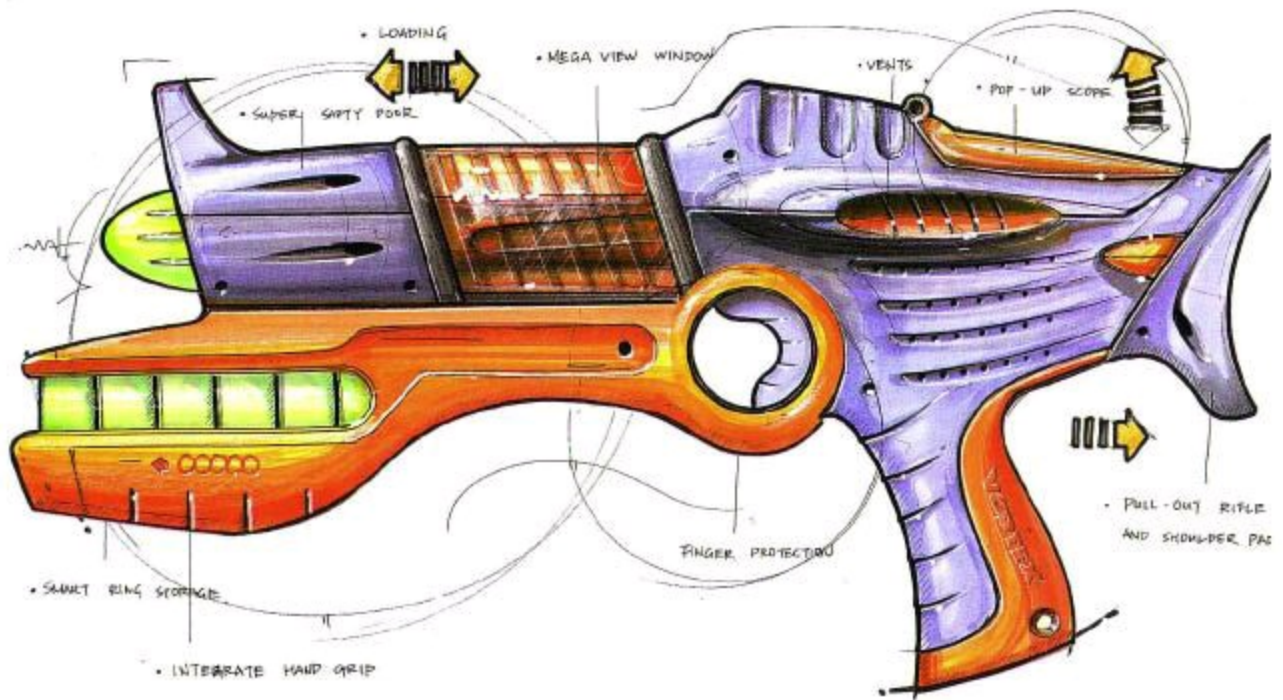

One of the final proposals.

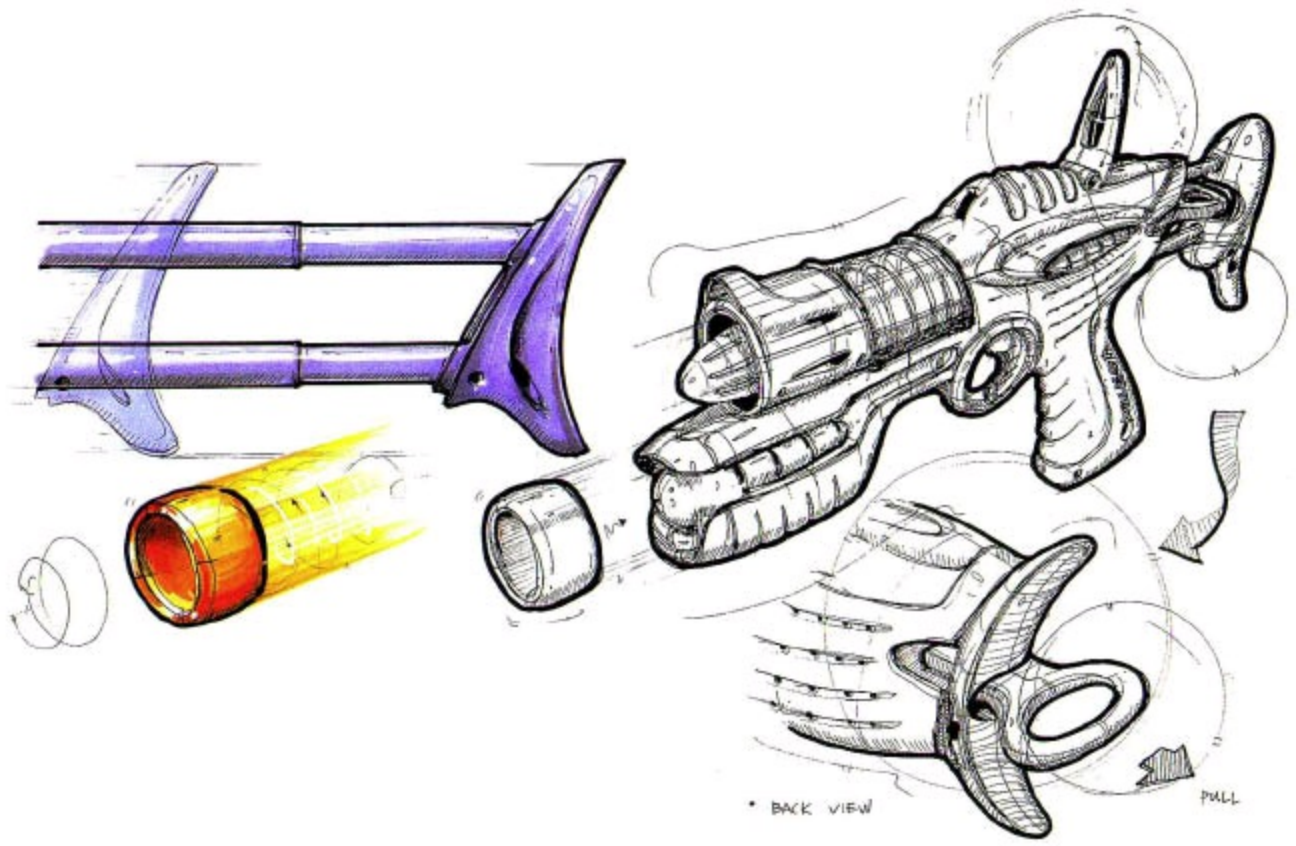

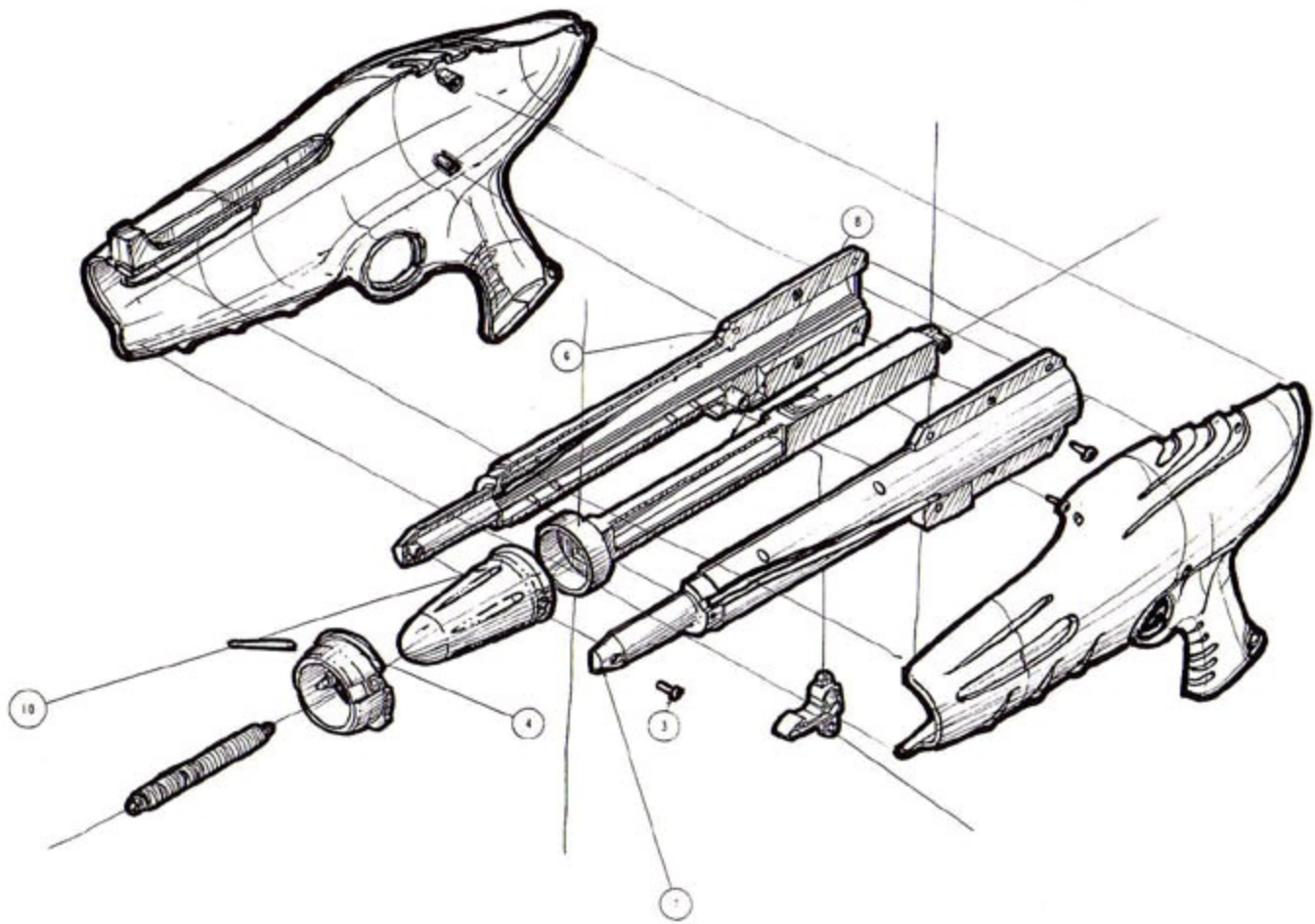

Exploded view shows part assembly. The idea was to keep the same launcher mechanism, but the outside skin could be designed differently.

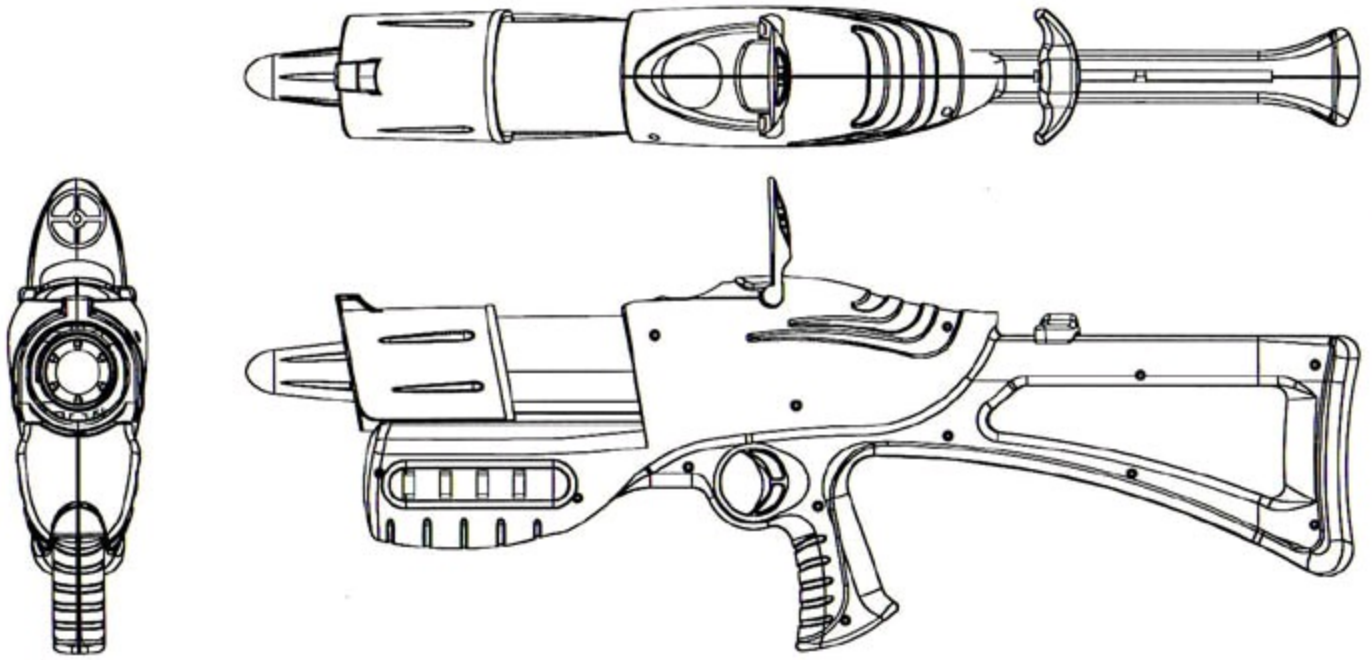

ProE 2D layout for the final ring shooter.



Early concept





2D Photoshop rendering.



This page shows color proposals for the final designs. The client preferred colors in strong contrast to attract kids.



Prototype



ProE 3D model



Final product



The shooter in package



Photos of mini shooters.



A gift from Function Engineering, limited addition in a translucent shell.







## BEFORE DEMO...WHAT TOOLS?

**T**here are so much art materials you can choose from the art stores. It is really difficult to say what is better than others. The best way is for you to try it out then find out what suits you the most. At school, I had learned or tried almost all the media I could get my hands on. It seems to me till today that the most basic media works the best for me.

I used to use ball point pens to draw on Xerox paper, because ball point pen drew smoothly. It could be gently applied on paper as a draft. It worked like pencils but ran better on normal copy paper. I use ink pens now instead of ball point pens because the final sketch scans better with even black ink. Markers by far are still the handiest and portable media for me in terms of color in a sketch. Water-based markers are more popular these years because they are safe, no harm to your body. The disadvantage of water-based marker is easy to dry up; must remember to put the caps back on after you done using them. Solvent-based markers are waterproofed and permanent. One of my favor marker is Chartpak Ad marker, because the colors are so opaque, specially the super black. The special nib design can easily draw in variable line weights. It almost gives the flexibility like a Chinese brush. I also use quite a bit color pencils for my sketches. If I want to do a more expressive sketch, I use black Prisma color pencil for baseline, just because it shows a better gradation. For example, pencils give a fade out effect instead of a sudden stop when I draw a single line. White Prisma color pencil is mainly for high lights and reflection. With one marker, one black Prisma and one white Prisma, I should be able to describe a form and details. Other color pencils can be used as a second light source to describe the contour of the object if the drawn object itself does not have too many colors. The popular colors are orange and purple to represent warm and cool light sources.

Tools like ellipse guides, circle templates, straight edges and curve sets are ok to use. It does not make sense a sketch can only be done by free-hand. Of course, if you can draw precisely only by free-hand, you would probably draw faster than a tool user.

Two reasons for why I prefer tracing paper than normal copy paper, first, the color pencils work better with tracing paper due to its fine texture; second, the marker does not bleed like it on copy

paper. However, copy paper is cheap and easy to buy, although the marker bleeds, but you can build up color gradations with a single marker. It also works well with ink pen.

Remember! The tools are tools. They should not affect your design and thinking. Choose the tools and media you feel comfortable to use to create your own style.

## WHY SKETCHING?

Imagine you have so many great ideas wanting to share with other people, although you try your best to describe verbally about your ideas, you find almost impossible to let everyone understand what it is really in your mind.

Sketching is a basic skill for a designer. It is a tool for communication. Often time, designers need to convey their ideas through visual presentations. Although there are various ways to achieve the goal, sketching is the most handy, effective and economical tool to quickly illustrate designers' brilliant ideas.

Although the most important purpose of sketches is for communication, a great sketch can also reflect and record a designer's design intension and design emotion. A nice sketch expresses the desired feeling of the design. When a sketch or drawing communicates to a level beyond just design features, form factors and problem solving, it provides a psychological influence to the clients or viewers. A nice sketch can also indicate the proper environment and create mood of the design. It suggests user profiles and suitable personas. However, if you as a designer can master this tool, it really would save your energy to explain your idea verbally.

Hopefully you boss tells you this after reviewing your sketches.... Excellent job, the design feels right  
“



Electrical pencil sharpener (Panasonic)



The pens I use to create drawings. Marker, sharpie, fine ink pen, black prismacolor pencil



Sanford Prisma Color

# MY MP3 PLAYER

From this demo, you will learn:

- Page composition
- How to draw on tracing paper
- Pencil technique
- Core and shadow







Drew the basic shape of the MP3 in correct perspective.



Once I got the basic shape, I started to fill in details and made the lines darker.



After I was pretty much done with the main view, I drew the second object on the page which was the rear view of the MP3.

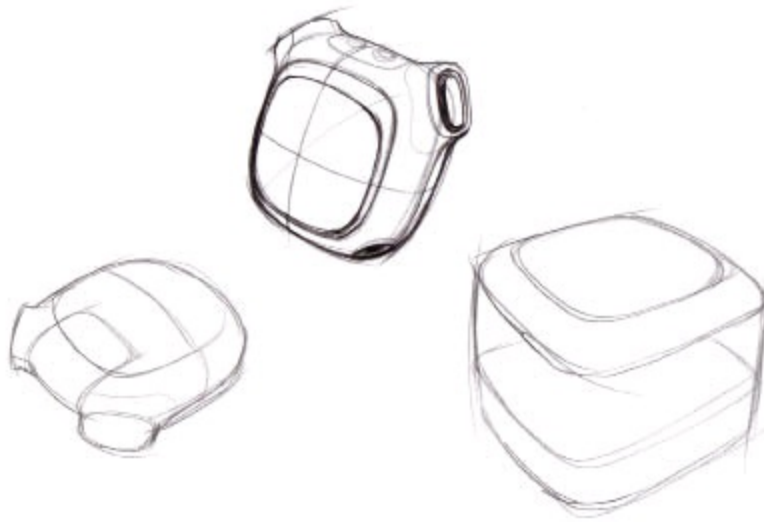

I decided to add a charger/speaker for the MP3. It is a basically a cube but I had to get the perspective right so the three objects on the page were well balanced.

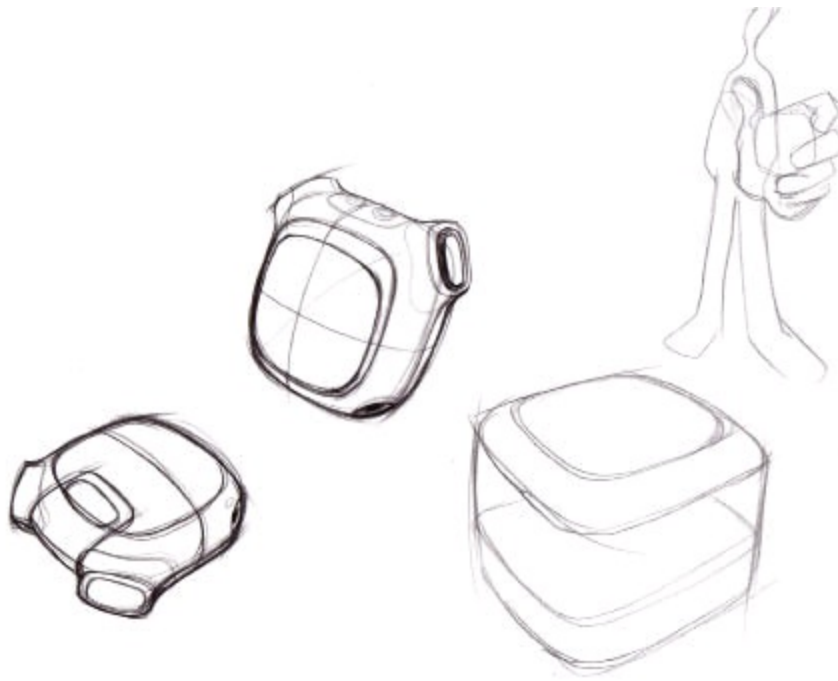

I felt like to put a person to show how to hold the MP3, so I drew a not so detailed figure just for an indication.

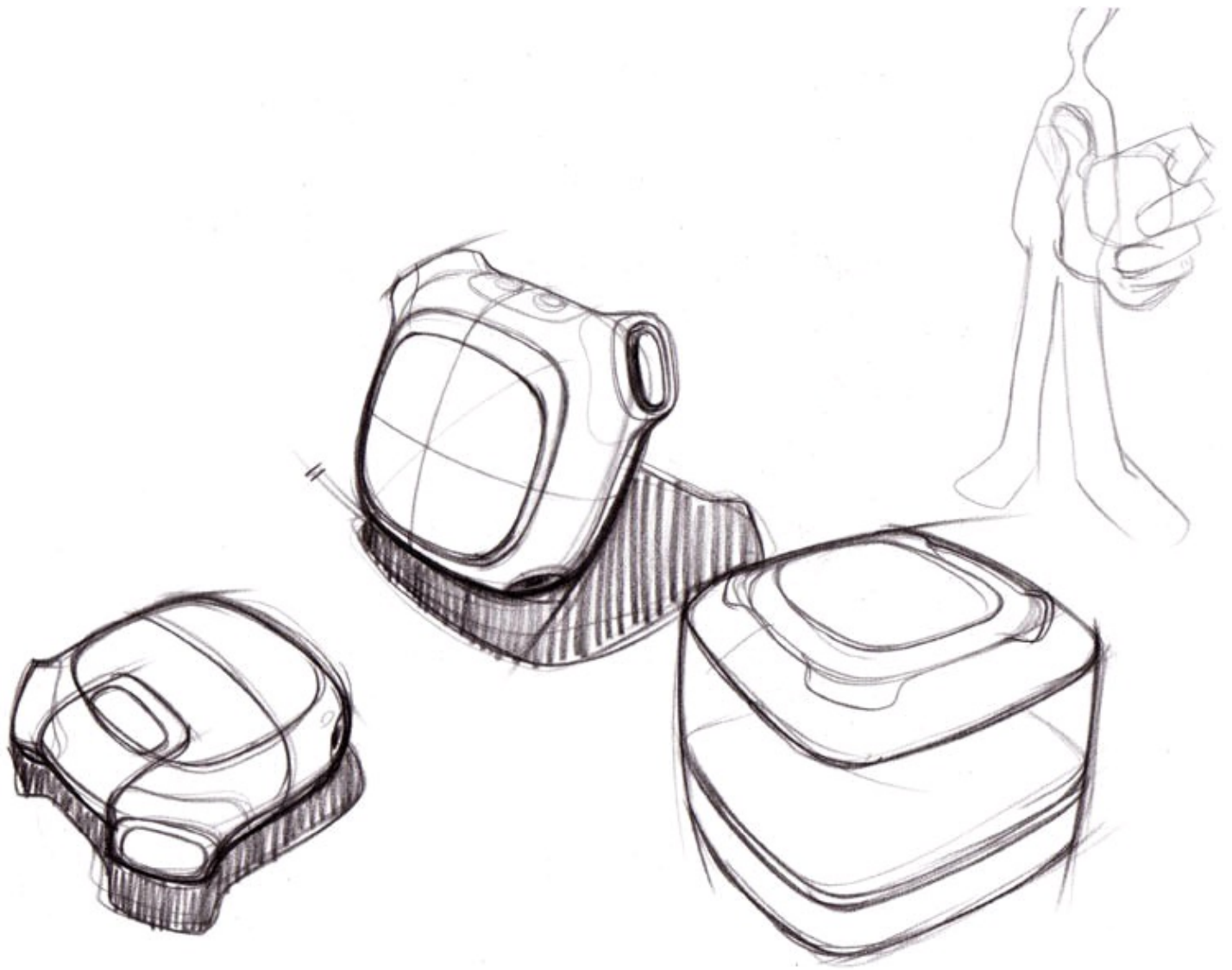

Heavy pencil lines to define the basic shape of the mp3 sound cradle. Added shadows on the MP3 so they looked on a flat surface.

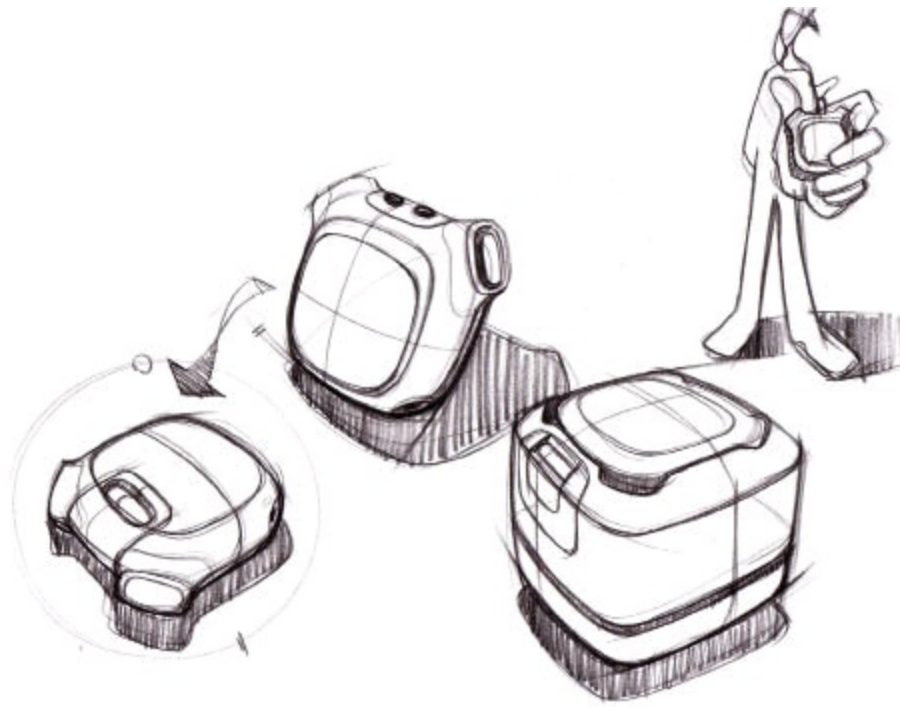

Filled in details on the cradle design. Added an arrow to indicate the other side of the mp3. Filled in more details on the mp3. Redrew a person holding the device.

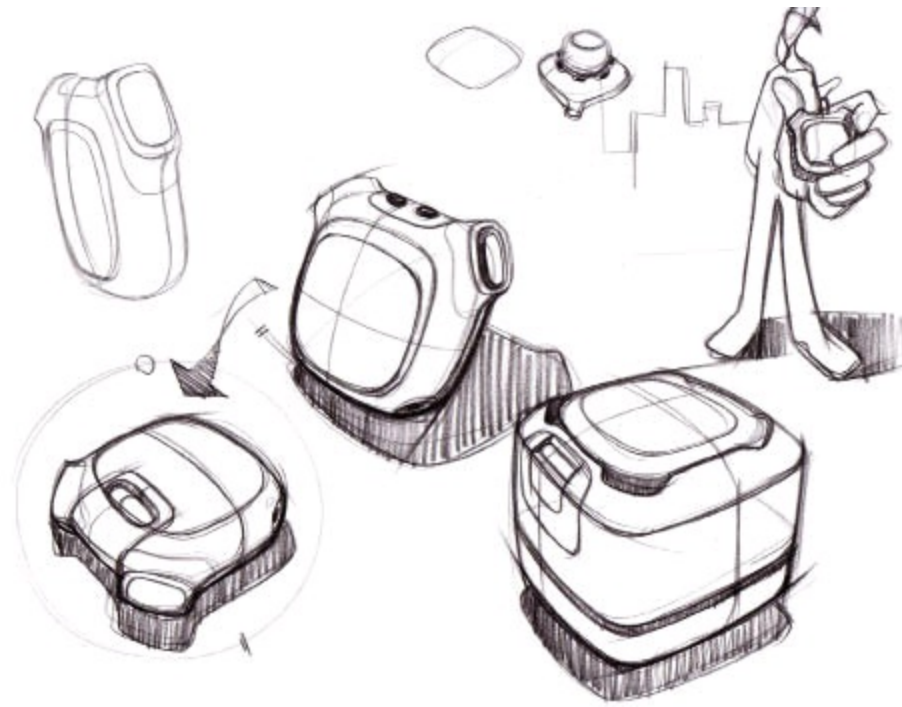

Light pencil to draw the mp3 in different perspective. Designed ear bugs to match the mp3 design..



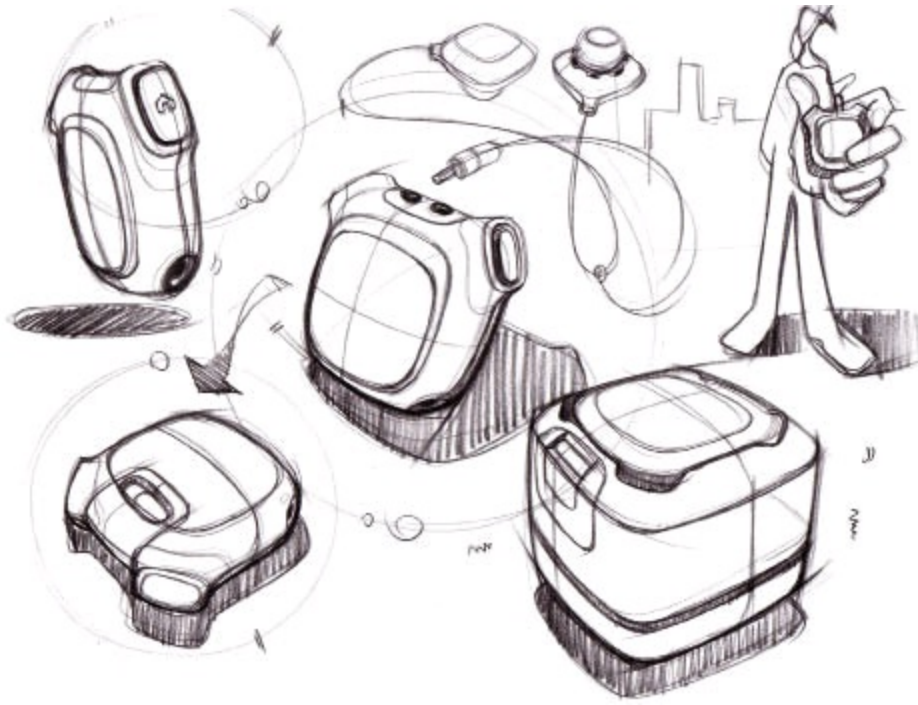

Heavy pencil to finish the last view and ear bugs. Added shadow for the new perspective mp3 to make it. Look floating in a space. Ready to throw colors on the sketch.



I used an orange marker for the main housing; the orange part was rubberized.

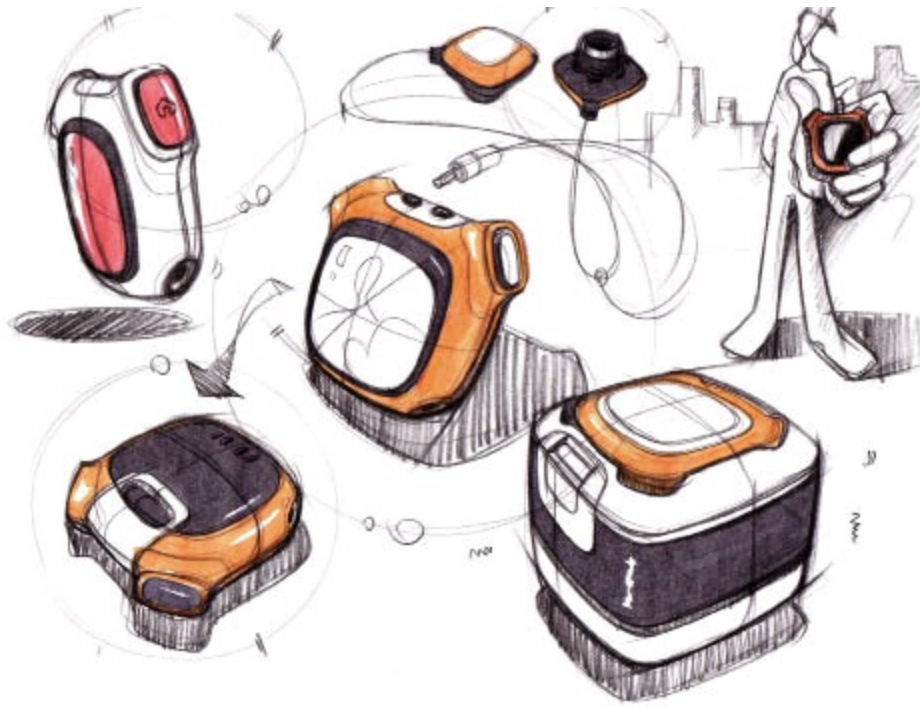

Then I filled in secondary color to show more parts.



Once I was pretty much down with the color in, I used black prisma pencil. To give cores and shades to make the mp3 look even more 3D. White prisma pencil would be applied the last for high lights.



Applied marker on the back of the tracing paper.

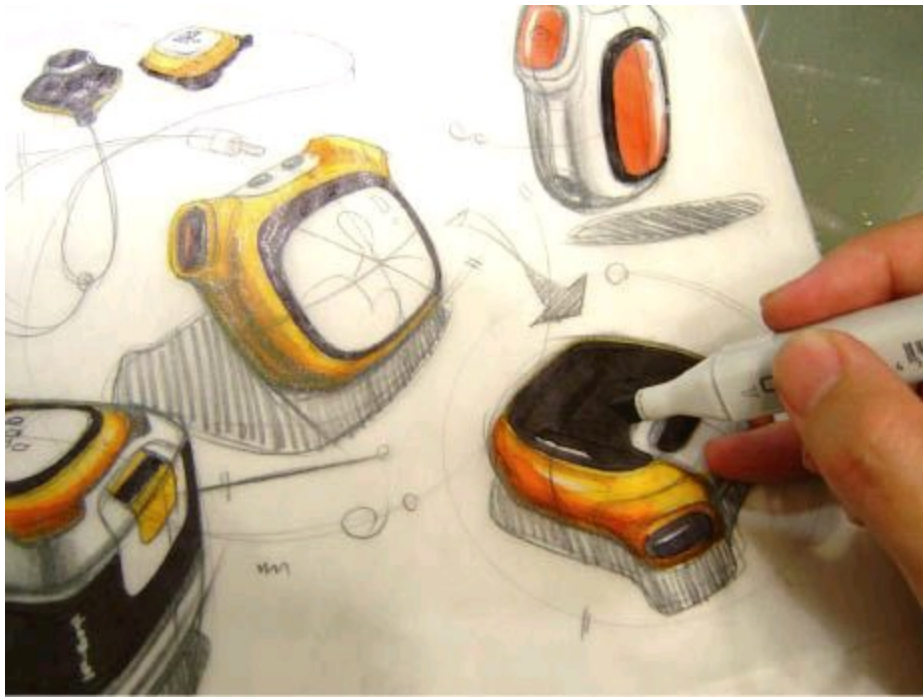

Remember to leave some blank for high light area.

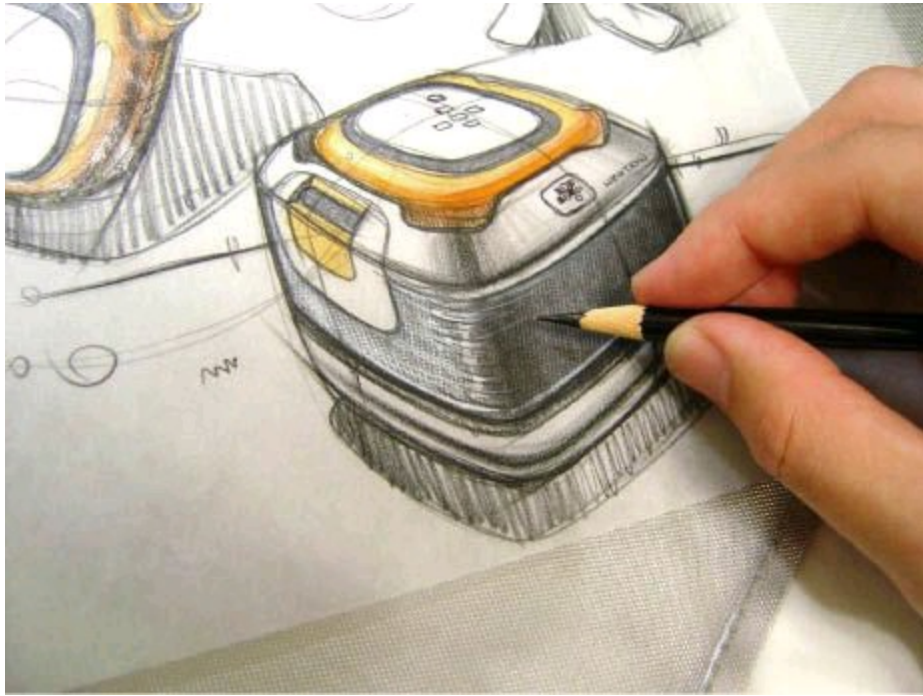

Black prisma pencil for cores. Paying more attention on how I was holding the pencil.



Sharpen your pencil frequently for better shades and details.



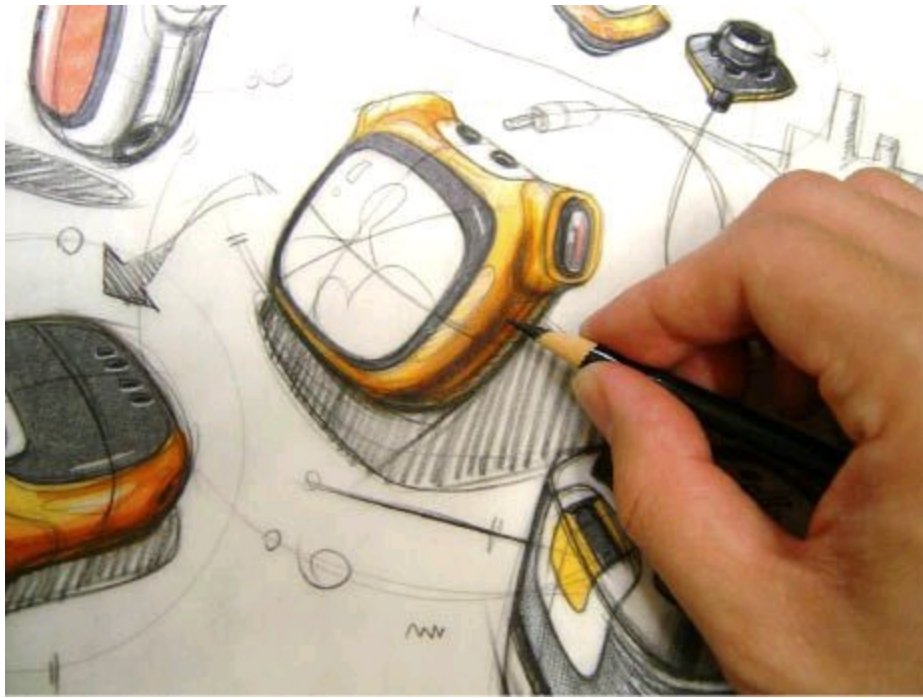

Kept applying the core to the MP3. Slowly built up the darkness of the core.

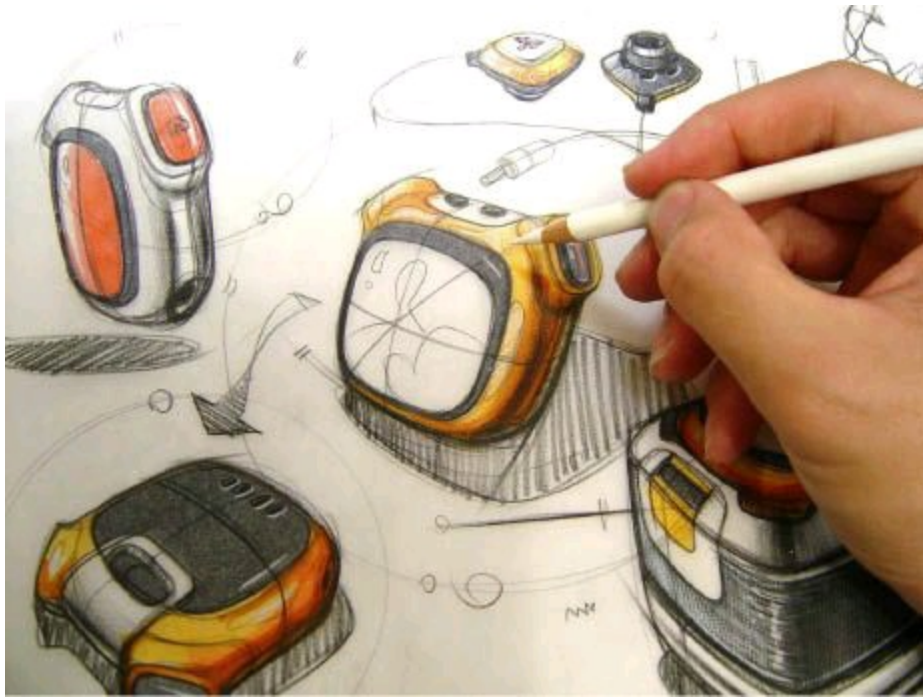

Used white prisma color to draw high lights. The white prisma color worked the best on a dark background color such as black.



Tools I had used for this sketch.

# SCOOTER

From this demo, you will learn:

- Draw Side profile to make it look 3D
- Fix up a rough sketch to a presentable drawing
- Use marker on copy paper
- Use marker on tracing paper
- Combination of Photoshop work







Ideation sketch of scooters. This was the one I chose for the final design.

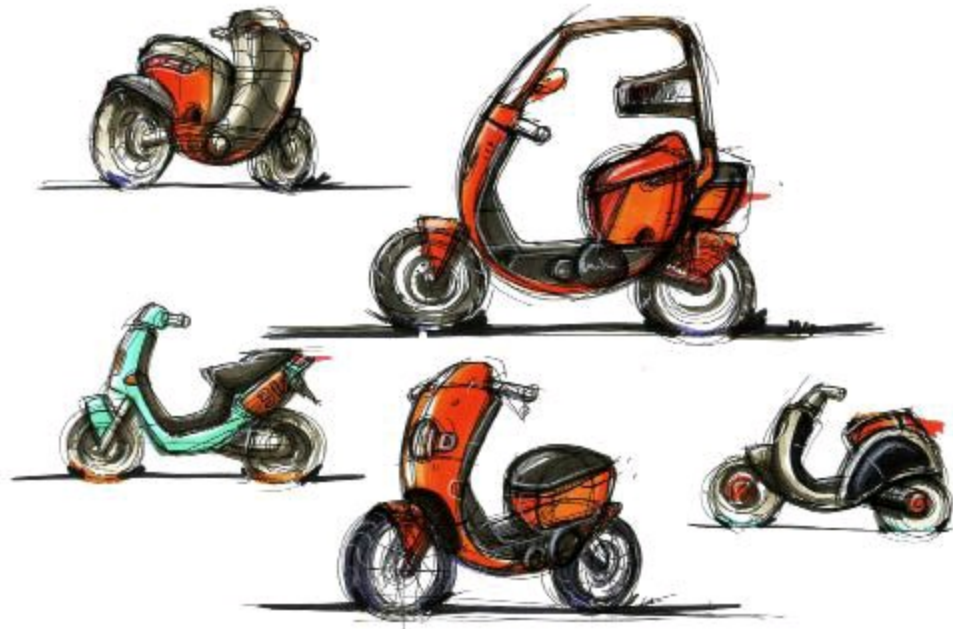



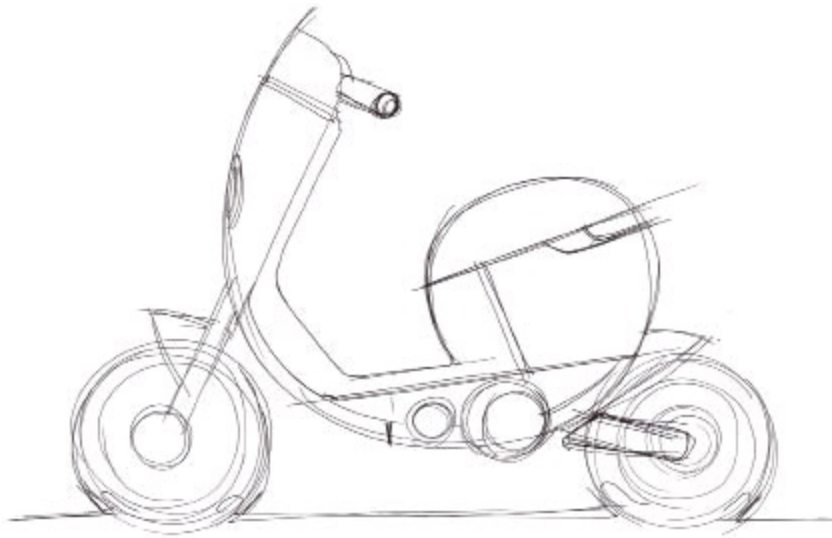

First I did a quick rough line drawing to get the overall design and proportion on copy paper with an ink pen.



I carefully traced over the design on to tracing paper then gave thick contour line.

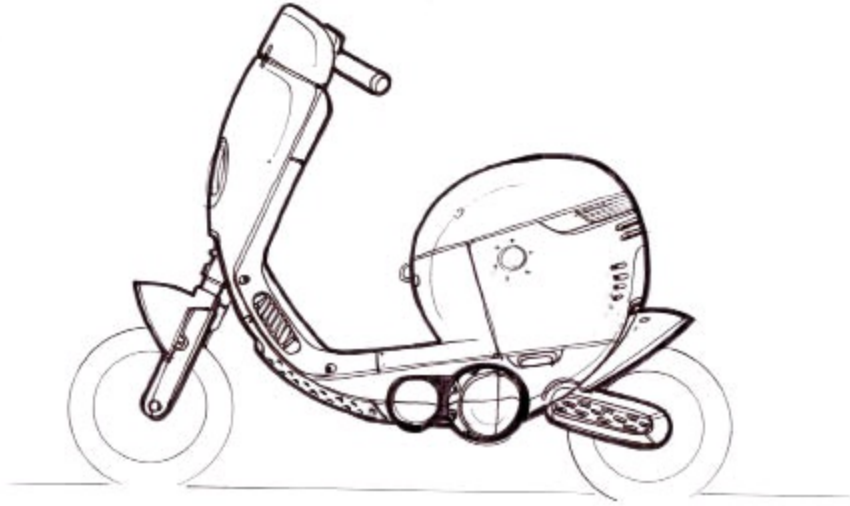

Refined and added more details to the scooter till it looked cool.

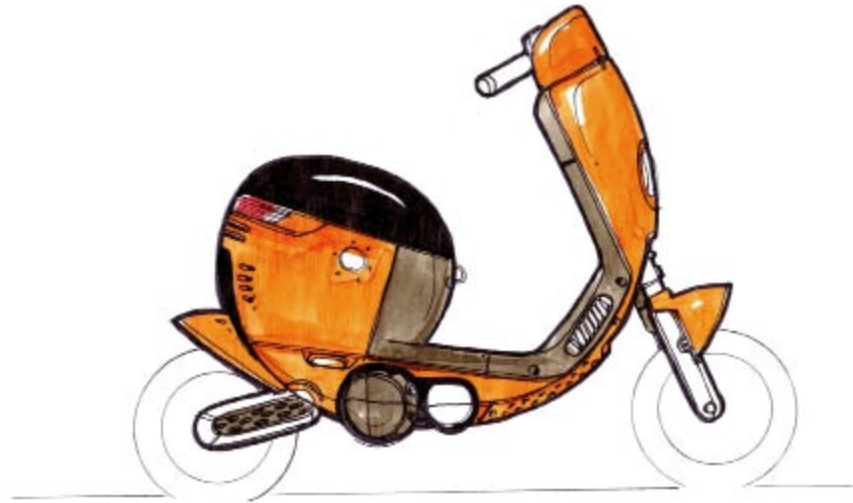

Flip over the tracing paper then block in the colors for the scooter.



I used Copic markers YR16, YR09 and R27 to get the result I want on the scooter body. I had marker on both sides of the tracing paper on this case.



Black and white Prisma color pencils to add high lights and shades.



Scanned the sketch then opened Photoshop; adjusted the Brightness/Contrast. I modified a found scooter wheel image then pasted the wheels to the drawn scooter. Added graphics to make it looked real. Added drop shadow on the ground; Finished.

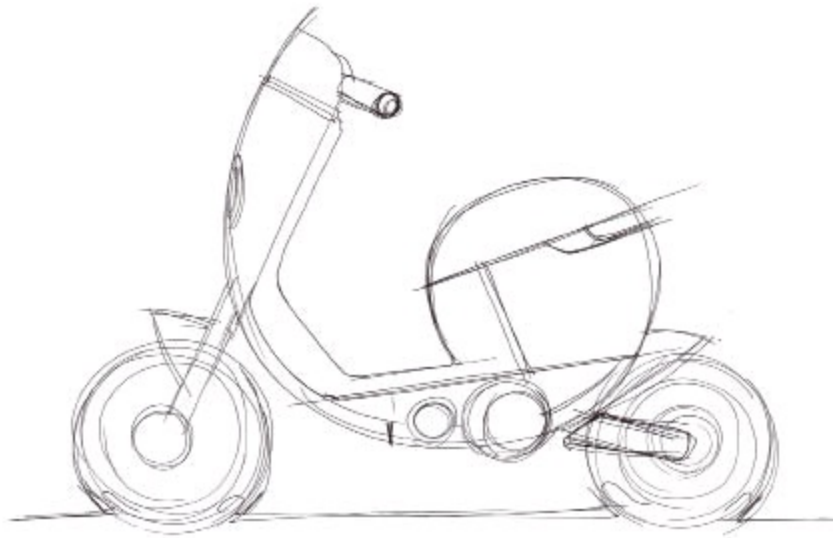

Reused the original draft



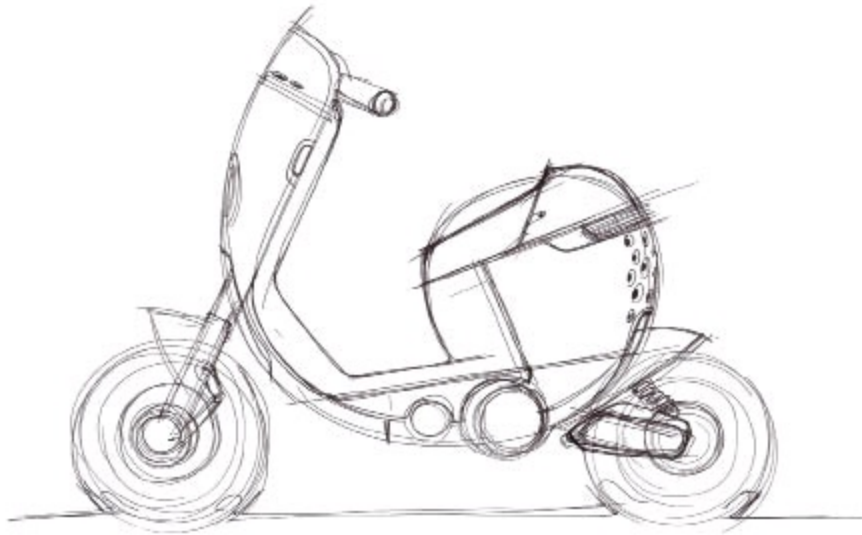

Changed the details or design till I liked it

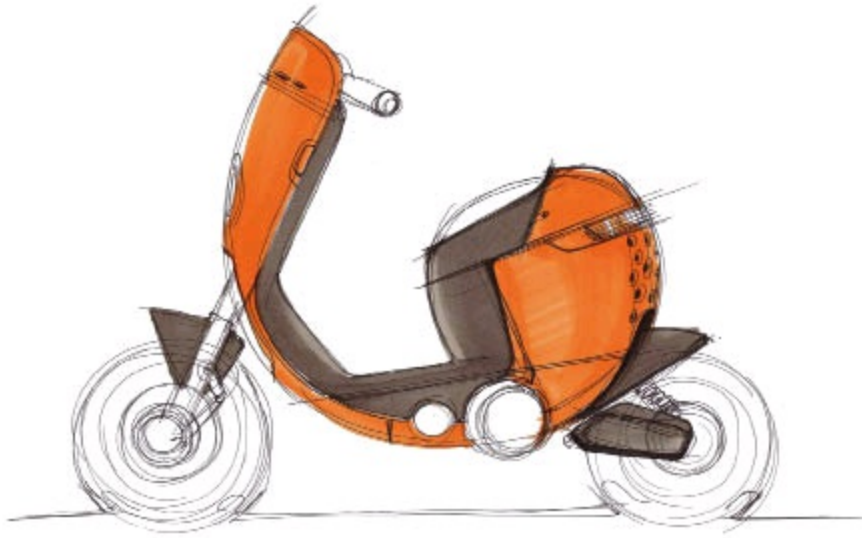

Filled in colors in major areas.

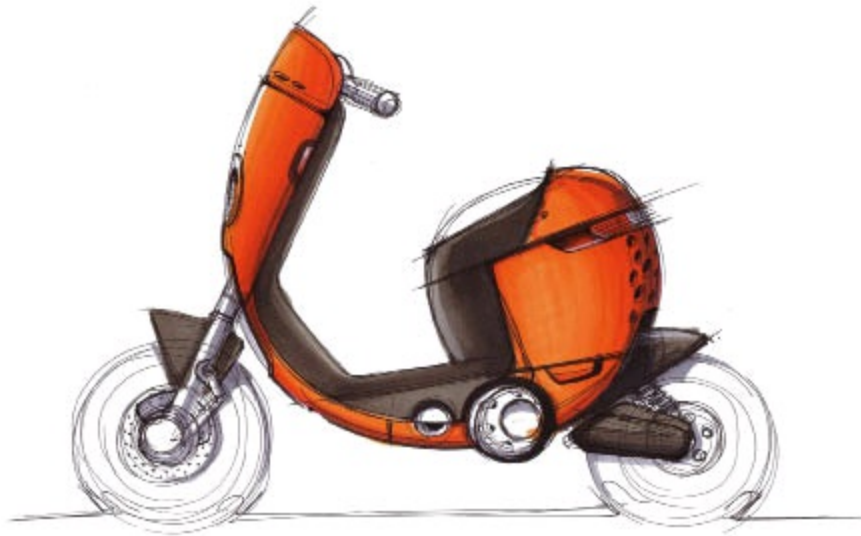

Built up the darkness and gradation on the scooter to show 3D effect with markers.

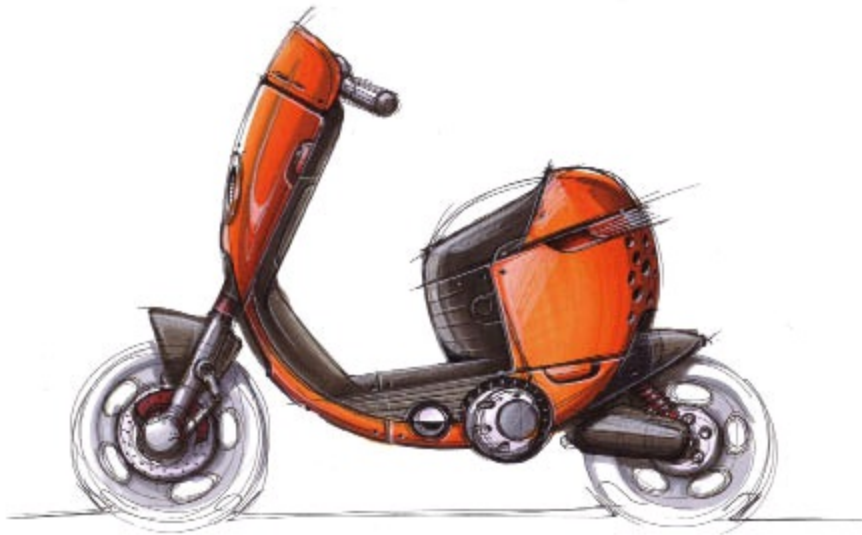

Added pencil work to define details on the scooter.



Scanned the sketch then used Photoshop to add wheels.



Added graphics to make it looked sporty.

## A LITTLE STORY ABOUT ME

I was born in Taiwan and finished my Junior College degree of Mechanical Engineering in Taipei. After college, I joined Army to serve my duty for two years. Life in Army was very tough in general. People from all over the country having extremely different backgrounds have to live and work together. Some people were very hard to deal with and always wanted to take advantage from others or bullied around. I did not have other choices but learned to live with it and tried my best to survive.

Many people say the Army turns a boy to a man. I believe it because my survival skills and strong wills that I have trained from the Army get me through all these years till today.

I found out Industrial design by accident when I was fifteen years old. My uncle loved books and he always brought books and foreign magazines to us children. One time he brought in a magazine called Design World. I was very attracted by all the pictures and articles in the magazine. One of the articles was written about a design firm in Australia. Designers worked in a bright and spacious modern glass house drawing new stuff what I had never seen it. I pictured myself sitting in the room and sketching... My dream started from that moment.

I was not able to study Industrial Design because there were only a few universities had ID major and my study grade was not good enough to get in any of them. So I studied Mechanical Engineering instead because I thought it was probably close enough to Industrial Design. Obviously, I was wrong.

I still carried my dream after I retired from Army. I took a TOFEL test but failed to pass and to be accepted by any art school in USA. My parents were thinking about moving to Canada at that time. Therefore, they decided to send me overseas and see if I could get in a good art school after taking some ESL (English as second language) courses. Somehow I knew this was my last shot to catch my dream and I could not let it slip away.

Life in Vancouver Canada was so different from where I grew up. Everything was so new and interesting to me. Besides the school class, I attended many after school activities. That really helped me to open up myself by socializing with people from different countries and understanding their

culture better. Influenced by the beautiful city and friendly people there, I started to become a more optimistic person.

I could not remember how many times I failed on TOFEL test before I finally got accepted by an art school in San Francisco, California College of Arts and Crafts. The good thing about this college was minimal portfolio requirement for entry students. I moved to Oakland and shared a house with two other students as well as the house owner. Most of my classes of the first semester were art foundations. I worked extremely hard and spent lots of time on my homework and projects. I only slept three to four hours a day and countless nights I worked all nights without any sleep. I still remember in the first Basic Drawing Class the instructor asked every student to draw the still objects so he could tell students' skill level. I was so embarrassed to show my work because my drawing was so awful comparing with other students' work. Well, I was probably the oldest student in that class and my drawing stinks. I whisper to myself that I could not lose my face and I had to work on my foundation skill extra hard. My hard work finally paid off. The end of that semester I got an A- from my highly respected professor who had only given out there As to his students during his twenty-year teaching carrier according to the seniors. Actually, I thought my work was not necessary the best in the class but my tremendous improvement was definitely recognized. For other studio classes, I was able to learn fast and to do quite well.

The end of my freshman year, there was an annual All-Collage-Student Competition for scholarship. I was suggested to try for an entry by a friend. I wasn't confident enough to submit my work when I found out I was going to compete with more than one hundred students but I did it anyway. Two weeks later, I got a letter form the scholarship committee to inform me that I had won the first prize. I could not believe what I saw. I was so happy and excited and kept saying I did it to myself. This experience was one of the important highlights in my life because this honor was the first major achievement through my entire student life, not to mention I was a foreign student trying to study an unfamiliar subject.

The coming semester was a lot better and easier for me because I started to design something tangible and practical. I designed a coreless phone, a spatula and a parking meter. I did pretty well in the class



and gained my self-confidence again.

During my study in CCAC, I always heard other students talked about the Art Center College of Design in LA Pasadena. I had read about the school and knew it was very difficult to get in and even more difficult to graduate. The minimal 550 TOFEL requirement was scary enough for me. I decided to check it out anyway. I drove about six hours from San Francisco to Pasadena then finally got to the school. It was probably a holiday or between semesters because the buildings were locked. Through a tinted glass, I could see some stuff inside the building. Once I stepped up and took a better look, I was absolutely blown away by what I saw on the other side of the glass. Beautiful design projects were nicely presented in a spacious gallery. I must be acted like a fool sticking my face on the glass for at least half an hour. Later I found out that Art Center had a Night Class program.

I decided to take the summer tern off and packed my stuff to LA. Although I only attended class at night I spent a lot of time in the campus to learn from other students.

I did quite well in the Night Class so I tried to apply for the transfer. Usually for foreign students we had to pass the English test and then the school would go through our portfolios. Once again, I was facing my biggest barrier, the TOFEL test, which failed me many times and I would hate to take another one. I scored 543 this time but the minimal was 550 to get in. Two weeks left before going back to CCAC. A note form school told me the chairman saw my portfolio and he liked it very much. I could even started form the second semester if I could pass the English test according to the school regulation. I had one last chance left or I had to return to CCAC. I had strong desire to transfer to Art Center not only because it was the best design school in America but also the class and program were more fit me.

I shaved my head and locked myself in a room for seven days. I studied TOTEL days and nights because my guts told me this could be another turning point in my life. I struggled to go back to San Francisco because I believed through Art Center's program that I should be able to apply more practical thinking to my future design carrier.

I finally passed the TOFEL test and scored 577. To many foreign students I knew, it was not a big

deal but it was for me because once again I proved it to me that there is a will there is a way.

Art Center was an extremely competitive environment. There were so many talented students working really hard to get great work done. Of course, quite a few excellent instructors were doing great jobs teaching passionately, but most importantly students learned from each other. Art Center's design program was very different from CCAC's program. One was strongly emphasized on design techniques and presentation skills, and the other was focused on creative thinking and design philosophy. I was blessed to have both disciplines so I was able to apply more conceptual thinking and practical content into my work besides just sculpting beautiful shapes. I think the combination of the capabilities still reflected on my design today.

When I was in the junior terms, I had a good habit to go around the senior studios everyday before I went home. Sometimes I would stare at a good sketch or rendering for twenty minutes and try to figure out why the drawing was so well done. Although it was so competitive among students, we shared what we knew and did our best to help others. Art Center life in general was hard but very happy and fulfilling because I loved so much what I was doing.

I was thirty years old when I graduated from The Art Center College of Design. I had a relatively decent portfolio and large quantity of work so I soon got job offers from quite a few well known design firms and corporations. Considering overall offers and working environment I finally decided to work for Astro Design in Palo Alto. Astro was a young and fresh design firm found by Brett Lovelady who worked as a V.P. at Frog Design and Lunar Design before. Brett was the most carried boss with sincere warm personality. He was a great designer himself but he had never asked his designers to change their designs. He trusted his designers and respected the team very much. His great vision and passion of making things better had led Astro become a successful design company. Kyle Swen was the Studio Manager and Rob Bruce was the Design Director. Kyle was like a brother to me when I worked at Astro. He was an all around designer who had great knowledge about how things made. I also admired his management style and people skill very much. Rob was an extremely talented designer and I picked up most of my drawing techniques and design mythology from him. His presence always made our studio feel energetic. I really appreciated what he taught me.

Mike Simonian was my idol at Art Center. He was a super star and I looked up to him a lot. He resigned from Fitch and joined Astro later. I was thrilled to work with him and learned from him not only design in general but also perspectives in life and things more important than design. I also enjoyed working with many other talented and fun designers like Dave, Nate, Stef, Ray, Victor, Danny, Terry and Susan. They were not just my colleagues but friends for life. I had my most memorable design experience there.

## ACKNOWLEDGEMENTS

I would like to thank all the friends and readers who support my first design book so I can continue sharing my experience and knowledge on the second book. Your feedback and guidance really help me to organize the second book in a way of helping people who are interested in design related work.